

new product

# EHP Series

NEMA-4X Rated



## FEATURES

- Fiberglass grey housing with captive screws. It is designed for heavy-duty industrial applications: indoors, outdoors, hose-down areas, cold-storage facilities etc
- NEMA-4X protection grade against liquids and windblown dust
- High ambient temperature up to 50°C [122°F] and optional cold-weather -40°C to 50°C [-40°F to 122°F]
- High temperature Lead-Calcium Battery
- High-efficacy LED emergency heads outperform traditional 50W halogen lamps
- Innovative head design: four-LED and dual-driver provide illumination even in case of unexpected component failure
- Product features stainless steel exterior hardware
- Simple and easy to install on walls, poles, columns or struts. For vertical installation on poles or columns use mounting bracket catalogue number: PMK1-E (sold separately)
- May be wired from top or side (see drawing for position)
- Standard infrared remote test control included in all models: allows to test the equipment without the need to climb a ladder. Functional up to a distance of 30 ft. Universal, one Remote Test Control may test all units on the job.
- Optional Audible and Non-Audible Auto-Diagnostic and Auto-Test
- Optional NEXUS® central monitoring system
- Meets or exceeds CSA C22.2 No. 141-15
- 1 Year limited warranty
- Advanced diagnostics capabilities (specific load requirements)

See warranty details at: [www.tnb.ca/en/brands/emergi-lite](http://www.tnb.ca/en/brands/emergi-lite)



## REMOTE TEST CONTROL



## DIMENSIONS

Dimensions are approximate and subject to change.

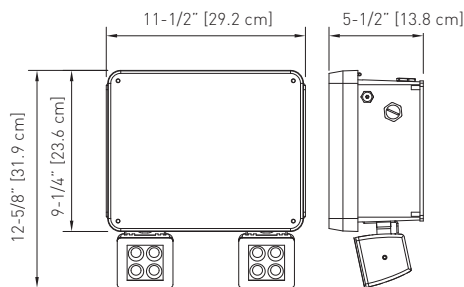

## INSTALLATION

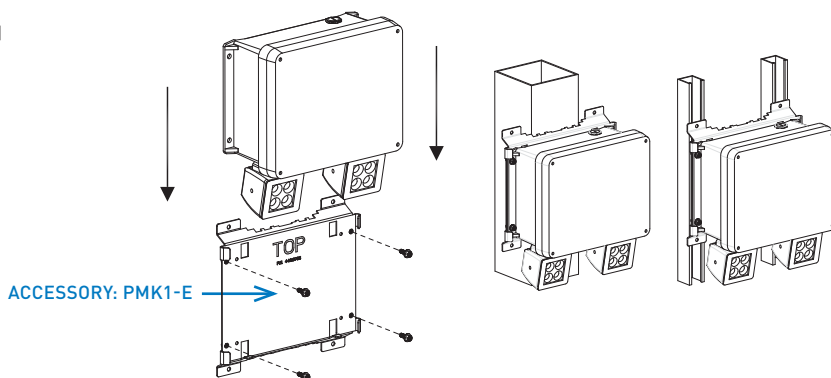

## TYPICAL SPECIFICATIONS

Supply and install **Emergi-Lite® EHP Series** of battery unit equipment. The unit enclosure shall have a compression-molded fiberglass construction and shall be equipped with a hinged, overlapping cover. The cover shall include a 3/16" wide rubber gasket and shall fasten with two stainless-steel captive screws. The enclosure shall have lateral flanges with holes for easy installation on the wall and also include two water-tight plugs of size 1/2" NPT for vertical and horizontal conduit and wire access. The emergency lighting heads shall be installed at the bottom of the cabinet and have the electrical cable passing through the swivel via water-tight bushings. The heads shall be made of Die-Cast aluminum and have a flat square lens made of UV-stabilized clear polycarbonate. The lens shall be sealed with a rubber gasket and be fixed with an aluminum frame and 6 (six) tamper-proof screws. Each head shall include four (4) LEDs and two independent LED drivers with electrical connections allowing for lighting even in case of unexpected component failure. Each head shall have an input voltage range of 12 - 24VDC and a constant power regulation, providing stable illumination during variations of the battery discharge voltage.

The equipment shall have a dual AC input rated 120/347VAC 60Hz and a charger module equipped with micro-controller and solid-state transfer relay. The charger shall perform functions like: AC brownout detection, battery lockout, low voltage battery disconnect, and provide protection against overcurrent, short-circuit, and DC reverse polarity.

Auto-Diagnostic option shall execute automatic tests for one minute every 30 days, 10 minutes every sixth month and 30 minutes every 12 months. In case of functional failure detection the equipment pilot light shall change color from green to red and signal a service alarm with specific flashing codes: battery or lamp disconnect, battery failure, charger failure, lamp failure. A label installed on the cover shall contain the legend with diagnostic codes. The equipment shall come standard with an infrared remote test control.

The equipment shall be rated NEMA-4X for hose down applications. The equipment shall be listed to cUL standards for Damp and Wet Locations.

Certified to CSA C22.2 No.141-15

Unit shall be **Emergi-Lite®** model number \_\_\_\_\_.

new product

# EHP Series

NEMA-4X Rated



## PHOTOMETRY PERFORMANCE

Whether installed indoors or outdoors, the **EHP Series** of LED emergency lights deliver a stable and consistent illumination on the path of egress for a wide range of mounting heights. Depending on the application, one may select and specify among three types of performance for the right power consumption, lumen output and cross reference to traditional incandescent emergency lights.

LED LAMP	POWER (W)	TOTAL LUMENS	OUTPERFORMS THE INCANDESCENT
L6	6W	565	35W PAR36, MR16 Halogen
L10	10W	1030	50W PAR36, MR16 Halogen
L15	15W	1320	50W MR16-IR Halogen

Industrial environment: wall mounted equipment, reflectances: 10/10/10; 6ft wide illumination path. 200 ft X 200 ft X 30 ft space. The illumination level meets all requirements of the NBC; Average: 1fc; Min: 0.1fc.

MOUNTING HEIGHT	SPACING CENTRE-TO-CENTRE (FEET)		
	LAMP L6 / 6W, 565LM	LAMP L10 / 10W, 1000LM	LAMP L15 / 15W, 1300LM
10 ft	80	110	140
15 ft	70	105	135
20 ft	60	100	130
25 ft	50	95	120

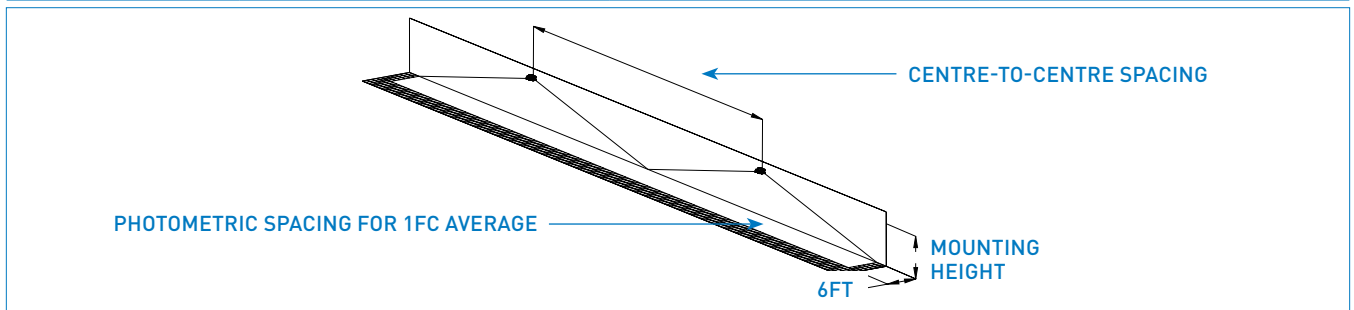

## POWER CONSUMPTION AND UNIT RATING

MODEL	AC SPECS			WATTAGE CAPACITY				
	120VAC	277VAC	347VAC	30 MIN	1H00	1H30	2H00*	4H00*
1275	0.20A	0.10A	0.07A	75	40	30	24*	15*
24150	0.37A	0.18A	0.12A	150	80	60	48*	30*
1275-CW	0.40A	0.25A	0.15A	75	40	30	24*	15*
24150-CW	0.50A	0.25A	0.20A	150	80	60	48*	30*

\*Note: the cold-weather option is only rated for maximum 90 minutes.

## ORDERING INFORMATION

SERIES	UNIT CAPACITY	# OF HEADS	LED LAMP TYPE	FUNCTIONS	OPTIONS
EHP= high performance battery	1275= 12V-75W 24150= 24V-150W	0= No Heads 1= One head 2= Two heads	L6= 12V, 24V-6W L10= 12V, 24V-10W L15= 12V, 24V-15W	Blank= no options U= auto-diagnostic, audible <sup>1</sup> UN= auto-diagnostic, non-audible <sup>1</sup> NEX= NEXUS® wired system interface <sup>1</sup> NEXRF= NEXUS® wireless system interface <sup>1</sup>	CW= cold-weather -40°C [-40°F] (120/347V) CW2= cold-weather -40°C [-40°F] (120/277V) D3= time delay (15 minutes) RF1= radio frequency interference filter (120/277VAC) RF3= radio frequency interference filter (347VAC) <sup>1</sup> -2= 277VAC, 60Hz input  PMK1-E= pole mounting bracket (sold separately)  <sup>1</sup> Not available with CW option.

EXAMPLE: EHP12752L6URFI