

ZCB Series

Zone Control Box

INTRODUCTION

The **Emergi-Lite® ZCB** Zone Control Box is required in buildings where the path of egress for emergency lighting crosses through several areas and each area has a separate electrical circuit and breaker for lighting. In such circumstances a local power failure in one area (zone) may not trigger the emergency lighting connected to a different electrical circuit. The requirement for the zone control function is specified in the National Building Code of Canada and the Canadian Electrical Code:

- NBCC 9.9.12.3. 3) Lighting required in Sentence (1) shall be designed to be automatically actuated for a period of at least 30 min when the electric lighting in the affected area is interrupted.
- CEC C22.1-12 46-304 (4) Unit equipment shall be installed in such a manner that it will be automatically actuated upon failure of the power supply to the normal lighting in the area covered by that unit equipment.



DESCRIPTION

The ZCB has several inputs to detect the AC voltage of each zone. It will activate all the emergency lighting if at least one zone becomes de-energized through either a power failure or lighting circuit breaker tripping. This greatly enhances the life safety system, as any failure of a lighting circuit will ensure emergency egress lighting in the entire building. As an optional feature, the ZCB can include test buttons and/or pilot lights, enabling individual testing of each zone circuit monitored. The ZCB can be included as an option in the **Emergi-Lite®** emergency lighting battery unit, with maximum 6 zone circuits. For a larger number of zones the ZCB is available in a separate enclosure (extension module).

TYPICAL SPECIFICATION: ZCB ZONE CONTROL STAND-ALONE EXTENSION MODULE

Supply and install **Emergi-Lite®** ZCB Series Model _____ of Zone Control Box. The equipment shall have _____ (maximum 24) inputs for line voltage detection from different building zones. The wire connection from each zone circuit shall be made with terminal blocks. The value of each zone voltage shall be: _____ VAC. The output circuit shall be a dry-contact relay, normally closed and shall be accessible for connection on a terminal block. The output circuit shall be connected at installation in series with the AC line supplying the battery unit equipment. The value of output line voltage shall be: _____ VAC. In the case of power failure of one or several zones the output circuit will open and transfer the battery unit(s) in emergency lighting mode. When specified the equipment shall include a 'push to test' push button and/or a pilot light for each zone circuit for manual testing and service. The unit shall be certified CSA 22.2 No.141-10.

The unit shall be **Emergi-Lite®** model: _____.

TYPICAL SPECIFICATION: BATTERY UNIT EQUIPMENT WITH ZCB ZONE CONTROL OPTION

When specified, the equipment shall have _____ (maximum six) inputs for line voltage detection from different building zones. The wire connection from each zone circuit shall be made with terminal blocks. The value of each zone voltage shall be: _____ VAC. In the case of a power failure of one or several zones the circuit will transfer the battery unit to emergency lighting mode for minimum 30 minutes. When specified the equipment shall include a 'push to test' push button and/or a pilot light for each zone circuit for manual testing and service. The unit shall be certified CSA 22.2 No.141-10.

The unit shall be **Emergi-Lite®** model: _____.

TYPICAL WIRING OF STAND-ALONE ZCB ZONE SENSING

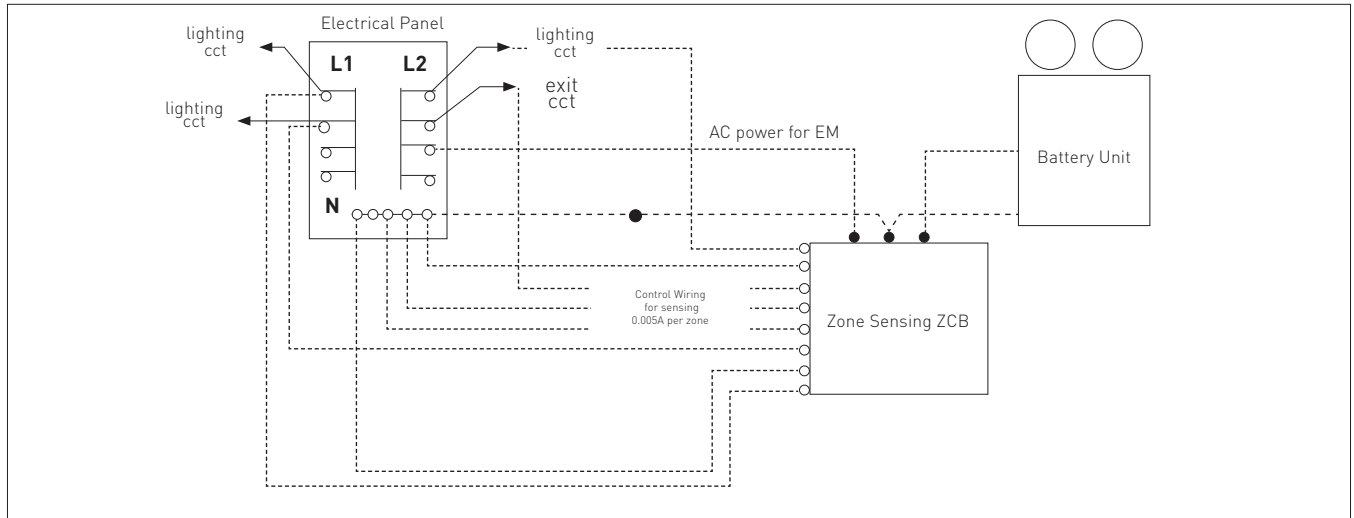

1. ORDERING INFORMATION: STAND-ALONE ZONE SENSING EXTENSION MODULE

AC OUTPUT TO BATTERY UNIT(S) (AC CURRENT DRAW: 8A MAX.)	SERIES	NUMBER OF ZONE CIRCUITS	AC INPUT OF ZONES	BATTERY UNIT	CABINET TYPE	OPTIONS
1= 120VAC 3= 347VAC	ZCB	2Z= 2 zones 3Z= 3 zones _Z= _ zones*	1= 120VAC 3= 347VAC	U1= 1 unit	A= A cabinet (max. 4 circuits)* B= B cabinet (max. 8 circuits) C= C cabinet (max. 24 circ. 120V; 16 circ. 347V)** PK= fiberglass (max.12 circuits)	PB= zone(s) test button* PL= zone(s) pilot lamp* *Only with cabinets: A, B and C
		*Max 24 zones Refer to cabinet type			*For 4 zones and combined PBPL options, use B cabinet **Max. 16 zones and combined PBPL option	

EXAMPLE: 1ZCB1Z1U1APB

2. ORDERING INFORMATION: BATTERY UNIT WITH INTERNAL ZONE SENSING OPTION

BATTERY UNIT CAT CONSTRUCT	UNIT AC INPUT	BATTERY UNIT CAT CONSTRUCT	OPTIONS				BATTERY UNIT CAT CONSTRUCT
	MANDATORY FOR ZCB		ZONE SENSING INTERNAL	# OF ZONES	ZONE AC	ZONE OPTIONS	
ESL Series p. 118-119 Distinction Series P.104-105 24ESL350	-1= 120VAC -3= 347VAC	ESL Series p. 118-119 Distinction Series P.104-105 U	ZCB= zone sensing	2Z= 2 zones 3Z= 3 zones Additional zone circuits (max. 6)	1= 120VAC 3= 347VAC	PB= zone(s) test button PL= zone(s) pilot lamp	ESL Series p. 118-119 Distinction Series P.104-105 /2MS

EXAMPLE: 24ESL350-1UZCB2Z1PB/2MS