



# Premier™ Series

Thermoplastic, 6 and 12V

## FEATURES

- Designed with aesthetics, ease of installation and performance in mind
- Simple, compact and contemporary design
- Wall-mount, ceiling-mount flat or pendant installation
- Two-piece housing of injection-molded thermoplastic
- Two MR16 LED lamps, shielded by clear polycarbonate covers
- Available with long lasting MR16 LED lamps
- Sealed, maintenance-free, Lead-Calcium battery
- Dual voltage input: 120/347VAC.
- Up to 150W of total battery capacity
- Auto-diagnostics (optional)
- NEXUS® interface (optional)
- Certified CSA 22.2 No.141



## TYPICAL SPECIFICATIONS

Supply and install the **Emergi-Lite® Premier™ Series** battery unit equipment. The unit construction shall include a housing and a front cover of high-impact thermoplastic moulded in white. No screws shall be necessary to hold the front cover to the housing. The unit shall be equipped with two emergency heads with adjustable swivels and MR-16 lamps of \_\_\_\_\_ V \_\_\_\_\_ W protected by snap-on shock-absorbent, clear polycarbonate covers. The unit shall be suitable for wall mount or as otherwise specified.

The unit equipment shall have a dual-voltage input of 120/347VAC and shall be equipped with a test switch and a green pilot light, located on the left side. The housing shall host the battery and the battery charger. The battery charger and other unit functions shall be driven by a micro-controller. All electronic circuitry shall be installed on a single printed circuit board.

When specified, the unit equipped with auto-test shall automatically self-test for one minute every 30 days, 10 minutes every 6 months and 30 minutes annually. When a fault is detected, the bi-colour pilot light shall turn from green to red and start flashing. A legend on a label next to the pilot light shall display the source of failure: battery, charger circuitry or lamp load.

The unit equipment shall be listed to the standard CSA 22.2 No.141.

The unit equipment shall be **Emergi-Lite®** model: \_\_\_\_\_.

## WIRE GUARDS

460.0080-E	Wall Mount or flat ceiling mount
------------	----------------------------------

## REPLACEMENT LAMPS

ORDERING CODE	LAMP TYPE	VOLTAGE/ WATTAGE
580.0097-E	MR16 LED	6V-4W
580.0122-E	MR16 LED	6V-5W
580.0093-E	MR16 LED	12V-4W
580.0104-E	MR16 LED	12V-5W
580.0106-E	MR16 LED	12V-6W

## PREMIER™ FAMILY



Premier™ Combo Series



Premier™ Exit Series

# Premier™ Series

Thermoplastic, 6 and 12V



## DIMENSIONS

Dimensions are approximate and subject to change.

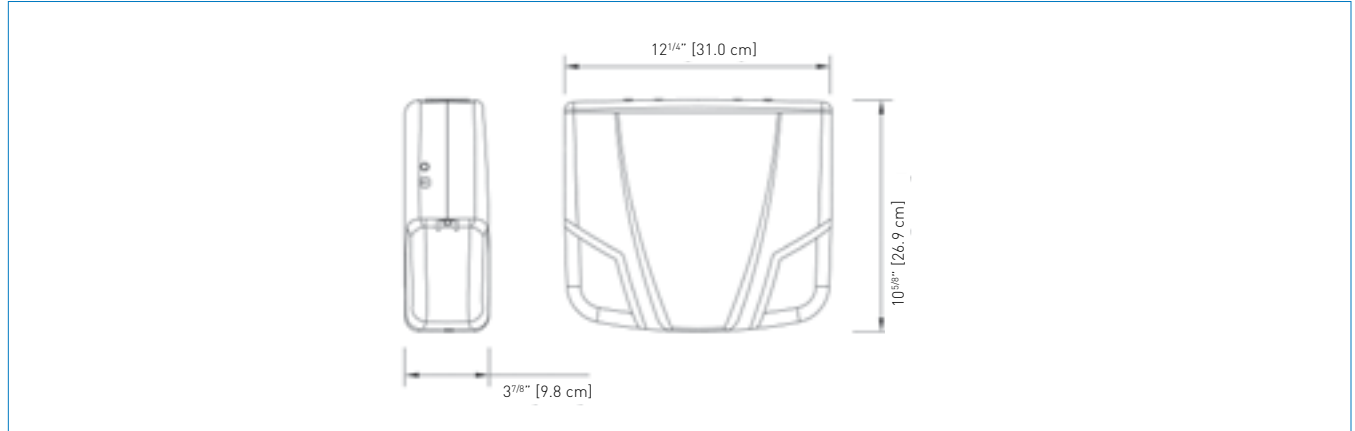

## FLAT CEILING MOUNT



## POWER CONSUMPTION AND UNIT RATING

MODEL	AC SPECS		WATTAGE CAPACITY				
			30MIN	1H00	1H30	2H00	4H00
PRE40	120/347VAC	0.25 / 0.09 A	40	23	16	12	-
PRE72			72	42	30	24	12
12PRE80			80	44	32	26	13
12PRE120			120	70	50	40	20
12PRE150			150	84	60	48	24

## ORDERING INFORMATION

SERIES	CAPACITY	COLOUR	VOLTAGE	UNIT TYPE	OPTIONS	HEADS	LAMPS
06PRE= 6V	40= 40W 72= 72W	W= factory white B= black	Blank= 120/347VAC 2= 120/277VAC	Blank= standard U= auto-diagnostics* UN= auto-diagnostics non-audible* NEX= NEXUS® system interface** NEXRF= NEXUS® wireless system interface**	Blank= no options CM= ceiling mount D3= time delay (15 minutes) LC= line cord (120V) PM= pendant mount	/0= no heads /2= two heads	LA= MR16 LED, 6V-4W LB= MR16 LED, 6V-5W LG= MR16 LED, 12V-4W LI= MR16 LED, 12V-5W LJ= MR16 LED, 12V-6W
12PRE= 12V	80= 80W 120= 120W 150= 150W						

EXAMPLE: 06PRE40W/2LA