

# Retract-a-Lite™ Series

## Remote Fixture



### FEATURES

- Remote only visible upon power failure
- Front can be painted or wallpapered on-site to match existing decor
- Fully automatic operation: The unit door opens upon supply with DC voltage from battery and closes after voltage disconnect. Time delay option required on battery unit to properly close the door
- AC line voltage not required
- Emergency lights: Two high efficacy LED lamps
- Certification: CSA C22.2 No.141

See warranty details at: [www.tnb.ca/en/brands/emergi-lite](http://www.tnb.ca/en/brands/emergi-lite)



### DIMENSIONS

Dimensions are approximate and subject to change.

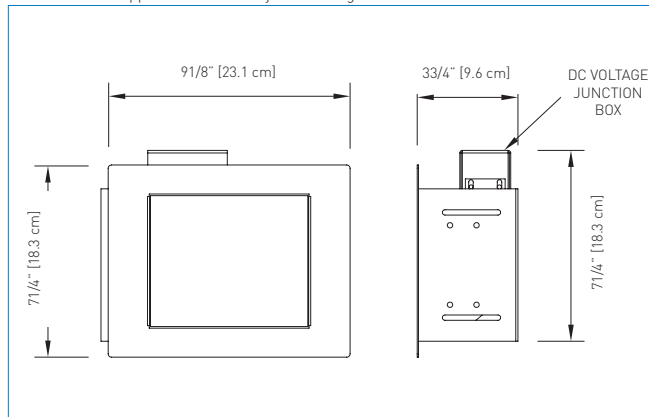

### TYPICAL SPECIFICATIONS

Supply and install **Emergi-Lite® Retract-a-Lite™ Series** of remote fixture: The unit shall be designed to be concealed in walls or ceilings with a cavity. The unit equipment shall be completely concealed in the wall or ceiling in the absence of remote power. Upon DC power supply the unit will rotate its door by 180° to expose the emergency lamps, and power them. After the DC power disconnect the lamps will turn off and the unit will conceal the heads by rotating the door by 180°. The DC-remote unit shall not require the presence of AC power in order to open or close the door.

Under normal conditions, the only visible parts of the unit shall be the off-white flat door and trim plate that can be customized on site with paint or other suitable wall covering. The light source shall be LED lamps of specified wattage and light output.

The remote unit shall be the **Emergi-Lite®** model: \_\_\_\_\_.

### REPLACEMENT LAMPS

MODEL	LAMP TYPE	VOLTAGE/WATTAGE
580.0093-E	MR16 LED	12V-4W
580.0098-E	MR16 LED	24V-4W
580.0100-E	MR16 LED	24V-6W
580.0104-E	MR16 LED	12V-5W
580.0106-E	MR16 LED	12V-6W

### WIRE GUARDS

460.0082-E	Wall Mount
------------	------------

### ORDERING INFORMATION

SERIES	WATTAGE FOR EACH OF THE 2 LAMPS	OPTIONS
<b>12RTL</b> R= 12VDC remote <sup>1</sup> <b>24RTL</b> R= 24VDC remote <sup>2</sup>	<b>-LG</b> = 2x MR16 LED, 12V-4W <b>-LI</b> = 2x MR16 LED, 12V-5W <b>-LL</b> = 2x MR16 LED, 24V-4W <b>-LJ</b> = 2x MR16 LED, 12V-6W <b>-LM</b> = 2x MR16 LED, 24V-6W	<b>TB</b> = T-Bar mounting kit

<sup>1</sup> The remote fixture is compatible with all Retract-a-Lite™ battery units.

<sup>2</sup> 12V-24V battery unit must include the time delay function & exclude diagnostic to close door: consult factory for details.

EXAMPLE: 12RTL-R-LGTB