



# HZM Series

Hazardous Location  
Battery Unit

## FEATURES

- Certified Class I Zone 2, Groups IIA, IIB and IIC
- Certified Class I Division 2, Groups A, B, C and D as per CSA C22.2 No.137-M1981
- Certified temperature codes for several types of emergency lamps
- Suited for areas with the risk of flammable gases, vapors or liquids that can create an explosive atmosphere
- Certified CSA C22.2 No141
- Polymeric frame, with built-in gasket to prevent water infiltration
- Heavy-duty 1/8" thick aluminum back plate with keyholes for secure wall-mount installation
- Two LED lamps, shielded by a cast aluminum housing and a polycarbonate cover
- Sealed, maintenance-free, Lead-Calcium batteries with up to 120W emergency power
- Built-in microcontroller-based battery charger and auto-diagnostics circuitry
- 1/2" electrical conduit entry on both sides and at the top
- NEXUS® compatible (for more information on NEXUS®, please contact your sales representative)
- Advanced diagnostics capabilities (specific load requirements)  
See warranty details at: [www.tnb.ca/en/brands/emergi-lite](http://www.tnb.ca/en/brands/emergi-lite)



## TYPICAL SPECIFICATIONS

Supply and install **Emergi-Lite® HZM Series** battery units. Designed specifically for Hazardous Location environments, the equipment frame shall be of industrial grade polymeric material with gaskets around both sides of the contour. The frame shall be fixed between two plates made of 1/8" thick aluminum sheet. The back plate shall include four keyholes for wall-mount installation. The front plate shall include two water-tight lenses for pilot lights: AC-on and "Service required". When specified, the equipment shall have attached a lower compartment containing two emergency lights with adjustable swivels and LED lamps. The lamps shall be shielded by a cast aluminum housing and protected by a shock-absorbent, transparent polycarbonate cover.

The equipment shall be certified for Hazardous Locations: Class I Division 2 Groups A, B, C and D. The standard equipment shall have a dual voltage input: 120/347VAC and shall be equipped with a magnetic test switch located on the left side of the frame.

The unit shall include self-testing/self-diagnostic functions monitored by a micro-controller and shall automatically self test for one minute every 30 days, 10 minutes every 6 months and 30 minutes annually. The "Service required" LED shall light when a fault is detected. A four-LED diagnostic display located inside the equipment shall identify the source of the failure (battery, charger circuitry, lamp load).

The unit shall be listed CSA C22.2 No.141 and No. 137 – M1984

The battery unit shall be **Emergi-Lite®** model: \_\_\_\_\_ .

## TEMPERATURE CODES

LAMP RATING	TEMPERATURE CODE	MAX. TEMPERATURE	REPLACEMENT PART NUMBER
6V-4W	T4A	120°C	580.0097-E
6V-5W	T4A	120°C	580.0122-E
12V-4W	T4A	120°C	580.0080-E
12V-5W	T4A	120°C	580.0104-E

Note: Use qualified replacement lamps to avoid risk of over-heating

## POWER CONSUMPTION AND UNIT RATING

MODEL	AC SPECS		WATTAGE CAPACITY				
			30MIN	1H00	1H30	2H00	4H00
HZM36	120/347VAC	0.15/0.06 A	36	21	15	12	-
HZM72	120/347VAC	0.30/0.10 A	72	42	30	24	12
HZM120	120/347VAC	0.30/0.10 A	120	70	50	40	20
HZM150	120/347VAC	0.30/0.10 A	150	-	72	-	-

# HZM Series

Hazardous Location  
Battery Unit



## DIMENSIONS

Dimensions are approximate and subject to change.

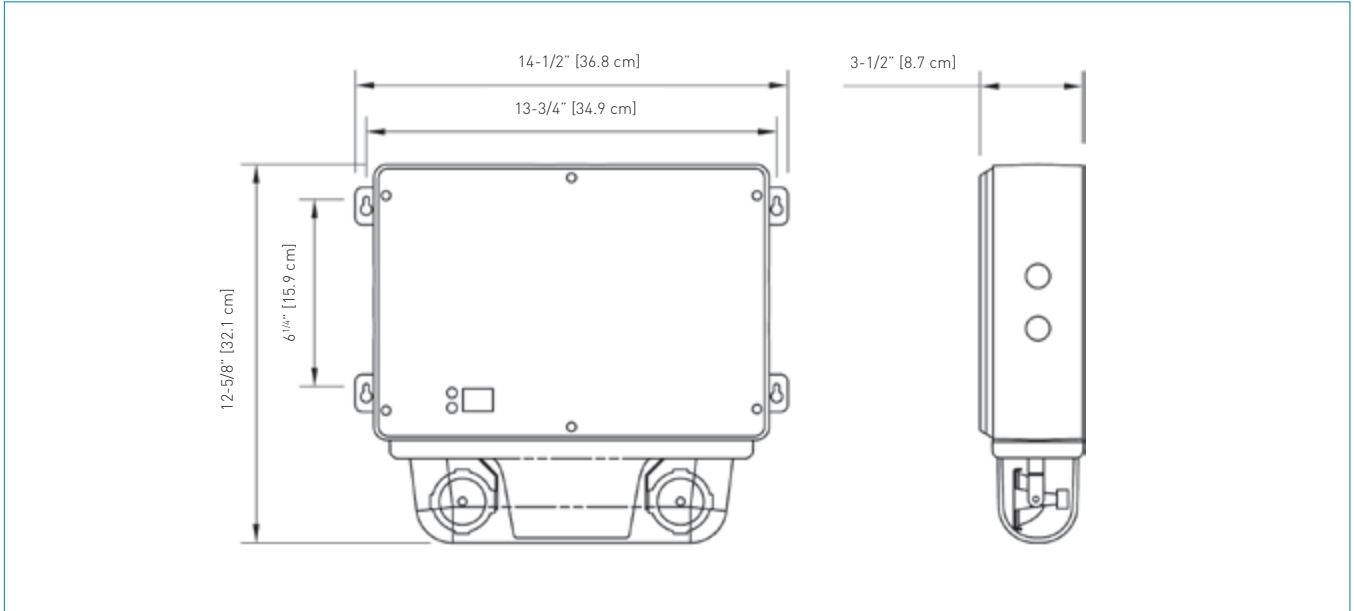

## ORDERING INFORMATION

SERIES	CAPACITY	COLOUR	AC VOLTAGE	CHARGER TYPE	# OF HEADS	LAMP/WATTAGE
06HZM= 6V 12HZM= 12V	36= 6V-36W 72= 12V-72W 120= 12V-120W 150= 12V-150W	Blank= grey	Blank= 120/347VAC -2= 277VAC	U= auto-diagnostics, audible <sup>1</sup> UN= auto-diagnostics (non-audible) <sup>1</sup> NEX= NEXUS <sup>®</sup> system interface <sup>2</sup> NEXRF= wireless NEXUS <sup>®</sup> system interface <sup>2</sup>	/0= no heads /2= 2 heads	LA= MR16 LED, 6V-4W LB= MR16 LED, 6V-5W LG= MR16 LED, 12V-4W LI= MR16 LED, 12V-5W
				<sup>1</sup> Minimum lamp load required: 20% of unit capacity		
				<sup>2</sup> Consult your sales representative for options available with the NEXUS <sup>®</sup> system.		

EXAMPLE: 06HZM36UN/2LG