



Lux-Ray™ LED Series

Rugged, Versatile, Sophisticated

FEATURES

- Die-Cast aluminum housing, available in four finishes: dark bronze, off-white, black, and platinum gray
- NEMA-3R Rated for indoor/outdoor wet and damp locations: -20°C to 50°C SD model
- Wall-mount installation on various junction boxes or via rigid conduit
- Patent-pending design for easy installation: wall-mount backplate includes electrical wire box with snap-on connector
- Patent-pending light engine: four power LEDs with redundant inter-connections and very wide beam
- Clear polycarbonate lens of reduced size (3" x 1.5"), shock-absorbent and UV-resistant
- Battery: high-temperature rated, Nickel-Metal Hydride technology
- Power consumption in stand-by: less than 5W
- Self-Test and diagnostic functions operated by micro-controller
- Certified to CSA 22.2 No.141-10 and No.250.0-08 standards
- 90 minutes run time

See warranty details at: www.tnb.ca/en/brands/emergi-lite

OPTIONS

- Cold weather: [-40°C... 30°C]
- Forward-throw light distribution, for applications of outdoor exit discharge (OSHA 1910.36)
- High-lumen output: 25 to 50% additional level of illumination compared to standard models
- Dual-mode operation: normal lighting and/or emergency lighting with separate AC inputs
- Photo-switch: dusk-to-dawn control of normal lighting
- Remote test: infrared remote control (keyboard ordered separately)
- Time delay: 15 minutes

IN THE SAME FAMILY



Luxray™ LED Remote Fixture

TYPICAL SPECIFICATIONS

Supply and install the **Lux-Ray™ Series of LED** emergency lighting from **Emergi-Lite®**. The unit body shall include a back-plate and housing made of Die-Cast aluminum with paint finish color: _____ and a UV- and impact-resistant polycarbonate lens of reduced size: 3-in by 1.5-in. The back-plate shall have knockouts for wires and wall-mount installation box as well as a threaded hole for rigid conduit entry at the top of the unit. The back-plate shall have a built-in electrical box with wire terminals and snap-on connector. After complete electrical installation of the back-plate the equipment housing shall be installed by a simple push & snap over the back-plate.

The emergency lights shall be 4 (four) power light-emitting diodes (LED) with operational life of minimum 36,000 hours, maintaining at least 70% of the initial light level (reported L70). The LED lamps shall have redundant interconnections: eventual failure of one lamp shall allow other LED lamps to function. The unit shall have a dual-voltage input rated 120/347VAC, 60Hz. The battery charger shall include low voltage disconnect to prevent deep discharge, battery lockout to prevent battery drain prior to energizing the utility power, and brownout protection which will automatically switch the unit into emergency mode if the utility power falls below 80% of nominal level. The unit with Nickel-Metal Hydride battery shall be equipped with a micro-controller-based non-audible auto-test circuit and provide minimum 90 minutes of emergency lighting. The unit shall self-test for one minute every month, 30 minutes every six months and 90 minutes annually.

The pilot light shall be integrated with the test button; it shall be a bi-color LED and shall change color from normal green to flashing red when a failure is detected from the battery, charger circuit or lamps. A label located near the pilot light shall describe the diagnostic for each flashing code. When specified, models with dual-mode illumination shall include two separate AC input circuits: un-switched for emergency lighting and switched for normal lighting. When specified, models equipped with photo-switch shall automatically activate the normal lighting only from dusk till dawn, for additional energy savings. The typical ambient illumination for the photo-switch shall be 10 lux (to turn-on) and 30 lux (to turn-off).

When specified, the unit shall be controlled by an infrared remote control keypad (ordered separately). The remote control shall be able to simulate a power failure of 1 minute, 30 minutes or 90 minutes and also to cancel the test in progress at any time. For units with dual-mode lighting the remote keypad shall also control the normal lighting with on/off switch and dimming functions. The unit shall be certified to CSA 22.2 No.141-10 for minimum 90 minutes and No.250.0-08 standards.

The unit shall be **Emergi-Lite®** model: _____.



NEMA-3R



POWER CONSUMPTION

MODEL TYPE	AC SPECS: 120/347VAC				6-12VDC REMOTE
	NORMAL LIGHTING		EMERGENCY LIGHTING		
	CURRENT (MAX)	POWER (MAX)	CURRENT (MAX)	POWER (MAX)	POWER (MAX)
ACSD, SD, SD-H	0.12/0.05 A	12W	0.05/0.02 A	5W	NiMH battery
SD-CW	-	-	0.16/0.06 A	16W	
ACSD-CWP, -CW-RC	n/r ¹		0.24/0.10 A	24W	

¹ Note: Only unswitched AC input; normal lighting with photo-switch or remote control

Lux-Ray™ LED Series

Rugged, Versatile, Sophisticated



**TABLE A: SPACING FOR AVERAGE 1FC/
NATIONAL BUILDING CODE, CANADA**

MODEL TYPE	MOUNTING HEIGHT	WATTAGE CAPACITY	
		SINGLE	CENTRE-TO-CENTRE
Standard	9'	6' X 50'	6' X 50'
With option -H	11'	6' X 60'	6' X 60' 3' X 70'
With option -FT	12'	6' X 40'	-
With option -FTH	15'	6' X 50'	-

Indoor reflectance: 80/50/20 and 10-ft wide corridor.
Outdoor reflectance: 0/30/10

Note: The illumination level meets ALL the requirements of the National Building Code-Canada and the Life Safety Code (NFPA 101):

- 1) Average of 1 foot-candle or more
- 2) Minimum at any point of 0.1 foot-candle or more
- 3) Maximum-to-minimum illumination uniformity ratio of 40:1 or less

**TABLE B: SPACING FOR MINIMUM 1FC
MAX./MIN. UNIFORMITY RATIO LESS THAN
3:1**

MODEL TYPE	MOUNTING HEIGHT	WATTAGE CAPACITY	
		SINGLE	CENTRE-TO-CENTRE
Standard	9'	4' X 28'	4' X 32'
With option -H	11'	4' X 32'	4' X 40'
With option -FT	12'	4' X 22'	-
With option -FTH	15'	4' X 27'	-

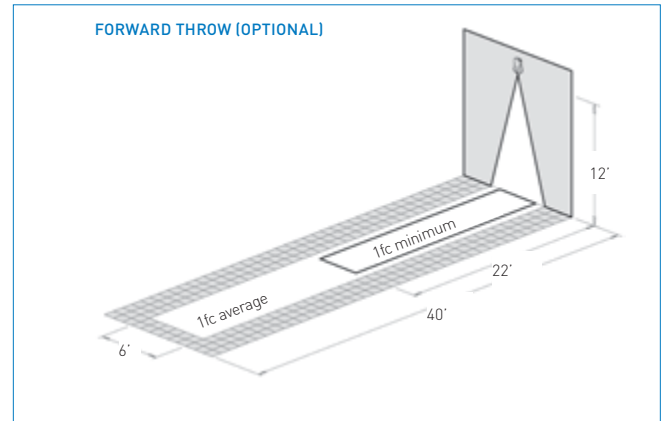
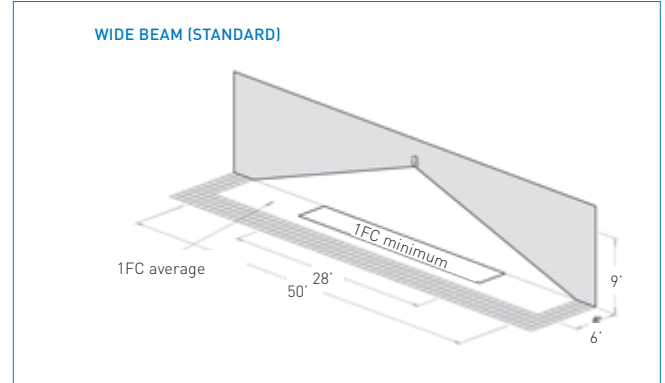

DIMENSIONS

Dimensions are approximate and subject to change.

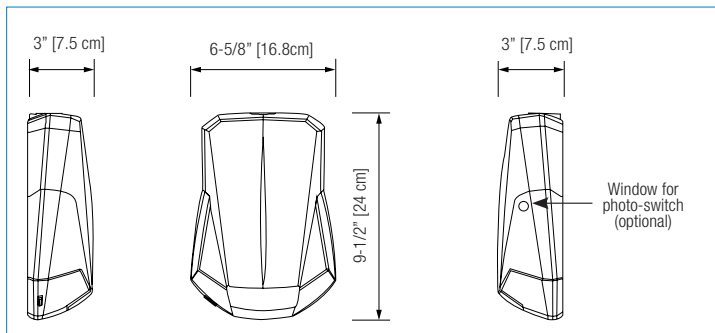

REMOTE CONTROL

Patent Pending



ORDERING INFORMATION

SERIES	FUNCTION: BATTERY UNITS	COLOUR	OPTIONS
LUX= Lux-Ray™ LED	SD= Self-Powered & diagnostic (0... 50°C) ACSD= Dual-mode AC/Self-Powered & diagnostic (0... 40°C)	BK= black BZ= dark bronze OW= off white PG= platinum grey	-CW= Cold weather (-40°C... 30°C; not available with option -H) -FT= Forward throw lighting -H= High lumen output (max. 30°C; model SD only) -P= Photo-switch (model ACSD only) -RC= Remote control - infrared ¹ -D3 = time delay (15 minutes) -2 = 277VAC 60Hz input

¹ Remote control keypad (TB-RC1-E) ordered separately.

EXAMPLE: LUXACSDBZ-P