

Nexus RF Addendum - Nema 4X & Class I Division 2 combo models

Antenna installation

Turn the AC power OFF. All electrical installations should be performed by a qualified electrician. The antenna supplied with this equipment must be installed as shown below in Figure 1.

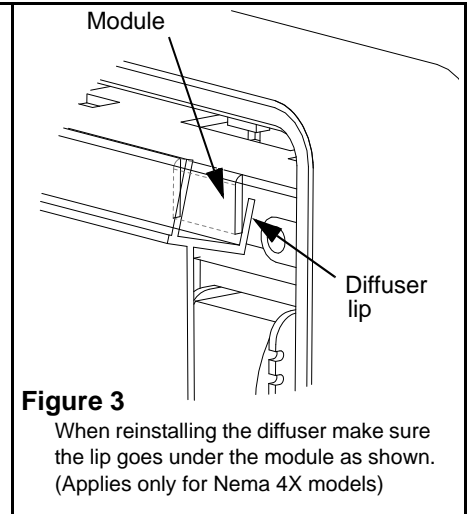
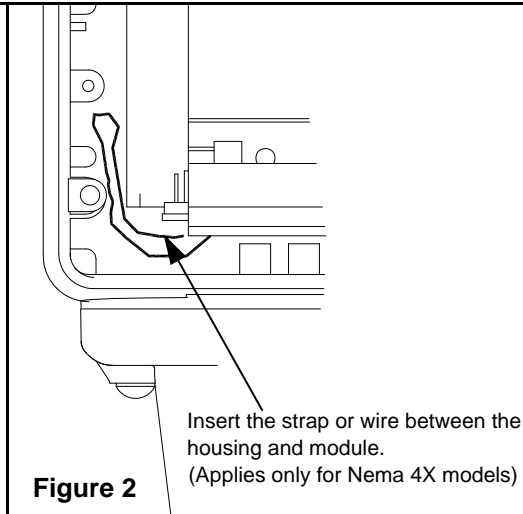
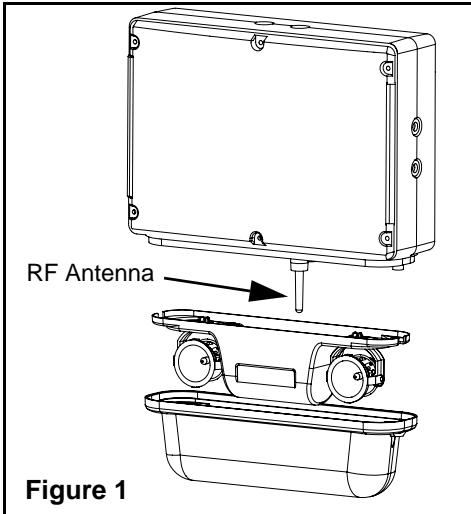

Figures for reference only

CAUTION! Handle the electronic module with care.

To avoid damaging the antenna, you must be vigilant when removing and re-installing the module. For double face models, you must first remove the diffuser to pull out the module from the frame (refer to installation instructions).

⚠ WARNING:

This device complies with Part 15 of the FCC Rules. Operation is subject to the following two conditions:

1. this device may not cause harmful interference.
2. this device must accept any interference received, including interference that may cause undesired operation.

Status LED

LABEL		INDICATOR ACTIVITY	MEANING
●	AC ON	Steady green	AC on
- ●	IN TEST	Blinking green	Testing in progress
●	BATTERY/LAMP DISCONNECT	Steady red	Battery disconnected and/or load disconnected
- ●	BATTERY FAILURE	1 red blink, then a 5-second pause	Battery failure
● ●	CHARGER FAILURE	2 red blinks, then a 4-second pause	Charger failure
● - ● ●	LAMP FAILURE	3 red blinks, then a 3-second pause	Lamp failure
● ● ● ●	LED STRIP FAILURE	4 red blinks, then a 2-second pause	LED strip failure (combo version)
●	SERVER FAILURE	Steady yellow	Server failure
- ●	BLINK MODE	Blinking yellow	Wink mode
- ● - ●	NOT COMMISSIONED	Alternating yellow and green blinks	Unit not commissioned

FCC Statement

This device complies with part 15 of the FCC rules.

FCC ID: W3BGC822843

This equipment has been tested and found to comply with the limits for a Class B digital device, pursuant to Part 15 of the FCC rules. These limits are designed to provide reasonable protection against harmful interference in a residential installation. This equipment generates, uses, and can radiate radio frequency energy and, if not installed and used in accordance with the instructions, may cause harmful interference to radio communications. However, there is no guarantee that interference will not occur in a particular installation. If this equipment does cause harmful interference to radio or television reception, which can be determined by turning the equipment off and on, the user is encouraged to try to correct the interference by one or more of the following measures:

1. Reorient or relocate the receiving antenna.
2. Increase the separation between the equipment and receiver.
3. Connect the equipment to an outlet on a circuit different from that to which the receiver is connected.
4. Consult the dealer or an experienced radio/TV technician for help.



IMPORTANT! Changes or modifications not covered in this addendum must be approved in writing by the manufacturer's Regulatory Engineering Department. Changes or modifications made without written approval may void the user's authority to operate this equipment.

Industry Canada

The term "IC:" before the certification/registration number only signifies that the Industry Canada technical specifications were met.

IC: 8100A-GC822843

Canadian Wireless Regulatory

This Class B digital apparatus meets all the requirements of the Canadian Interference Causing Equipment Regulations. Operation is subject to the following two conditions: a) this device may not cause any interference, and b) this device must accept any interference, including interference that may cause undesired operation of the device. To prevent radio interference to the licensed service, this device is intended to be operated indoors, and away from windows to prevent maximum shielding. Equipment (or its transmit antenna) that is installed outdoors is subject to licensing.

Unauthorized Antenna Modifications

Use only the supplied integral antenna. Unauthorized antenna modifications or attachments could damage the unit and may violate FCC regulations. Any changes or modifications not expressly approved by the party responsible for compliance could void the user's authority to operate the equipment.



Precautions against electrostatic discharge (ESD)

Make sure to discharge any built-up static electricity from yourself and your electronic measurement devices before touching this equipment. The recommendation from the dealer is that you take this precaution before installation and connecting this equipment.