



## RGS-TB Series

Decorative 6, 12 and 24 V  
T-Bar Unit



### Fully recessed units for T-Bar mounting in suspended ceilings.

The **RGS-TB Series** battery units are designed for T-bar ceiling grid installation. This slim-line, unobtrusive unit is ideally suited for any commercial location where there is limited wall space and where the greater directional flexibility of ceiling-mounted heads is needed to provide greater light distribution.

### FEATURES

- Rugged steel cabinet with corrosion-resistant undercoating.
- Battery and charger are concealed above the ceiling level in the unit cabinet
- Removable panel provides easy access to battery and circuitry
- Test switch and LED indicators are mounted on the visible bottom panel
- Units mount quickly and easily in standard 2' X 2' or 2' X 4' grids without any additional hardware
- Solid-state pulse-type charger – current-limited, temperature-compensated, short-circuit proof and reverse-polarity protected
- Unit comes standard with electronic lockout and brownout circuits
- Sealed dust-proof transfer relay, test switch and LED indicator lights
- Long-life, maintenance-free lead acid battery
- Auto-testing capabilities (specific load requirements)
- Meets or exceeds CSA C22.2 No. 141-15

### TYPICAL SPECIFICATIONS

Supply and install a complete emergency lighting system as described herein and shown on the drawings.

The **Lumacell® Smart Diagnostic** Micro controller board shall supply the rated load for a minimum of a 30 minutes to 87.5% of the rated battery voltage. The unit shall be rated 120V or 347V, 60 Hz and be CSA listed. The unit shall have an output of \_\_\_\_\_ V.

The charger shall be fully computer tested and its charge voltage factory set to  $\pm 1\%$  tolerance. Chargers with field-adjusted potentiometers are not acceptable. A pulse-type charger shall be employed to promote long battery life and reduce the potential for grid corrosion. The charger shall provide a continuous high charge to recharge the battery, when the battery is at full capacity, the charger will shut-off. Periodically the charger shall provide a pulse of energy to keep the battery topped off. The charger shall be current limited, temperature compensated, short-circuit proof and reverse polarity protected. The unit shall be furnished with an electronic lockout circuit, which will connect the battery when the AC circuit is activated, and an electronic brownout circuit, which will activate the emergency lights when utility power dips below 75% of nominal voltage.

A low voltage battery protection circuit shall be provided and will disconnect the battery from the fused output circuit at the end of discharge. The unit shall self-test for 1 minute every 30 days, 10 minutes on the 6th month and 30 minutes every 12 months. The unit shall be capable of full recharge in compliance with CSA specifications. The unit shall be furnished with sealed dust tight relay, a test switch and seven diagnostic LED indicator lights to continuously monitor the status of the unit: Battery Failure, Battery Disconnected, Charger Failure, Lamp Failure, Service Alarm, AC "ON", Charger High Rate. The unit shall be T-bar mounted and come complete with tool-less emergency lighting heads requiring no tools to adjust or aim.

The unit shall be CSA 22.2 No.141-15 certified.

The unit shall be **Lumacell®** model: \_\_\_\_\_ .

CABINET	DIMENSIONS				
	A	B	C	D	E
Large Cabinet	23-3/4" (60.3 cm)	7-1/4" (18.4 cm)	7-1/8" (18.1 cm)	10-5/8" (27.0 cm)	5-5/8" (14.3cm)
Small Cabinet	23-3/4" (60.3 cm)	7-1/4" (18.4 cm)	4-5/8" (11.7 cm)	10-5/8" (27.0 cm)	3-1/4" (8.3 cm)

### DIMENSIONS

Dimensions are approximate and subject to change.

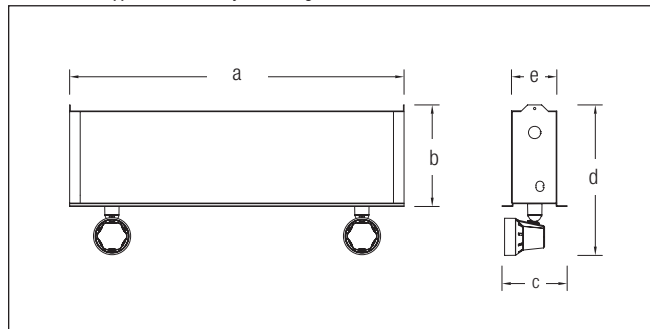

### REPLACEMENT LAMPS

ORDERING CODE	LAMP TYPE	VOLTAGE/WATTAGE
580.0097-L	MR16 LED	6V-4W
580.0122-L	MR16 LED	6V-5W
580.0093-L	MR16 LED	12V-4W
580.0104-L	MR16 LED	12V-5W
580.0106-L	MR16 LED	12V-6W
580.0098-L	MR16 LED	24V-4W
580.0100-L	MR16 LED	24V-6W



# RGS-TB Series

## Decorative 6, 12 and 24 V T-Bar Unit

### POWER CONSUMPTION AND UNIT RATING

MODEL	AC SPECS	WATTAGE CAPACITY				
		30MIN	1H00	1H30	2H00	4H00
RG36TB	0.10/0.04A	36	21	15	12	6
RG72TB	0.22/0.08A	72	42	30	24	12
RG108TB	0.22/0.08A	108	63	45	36	18
RG180TB	0.22/0.08A	180	105	75	60	30
RG12S36TB	0.09/0.03A	36	21	15	12	6
RG12S72TB	0.15/0.06A	72	42	30	24	12
RG12S100TB	0.34/0.12A	100	58	42	33	17
RG12S144TB	0.40/0.14A	144	84	60	48	24
RG12S216TB	0.41/0.14A	216	120	90	72	36
RG24S144TB	0.55/0.20A	144	84	60	48	24
RG24S288TB	0.67/0.23A	288	168	120	96	48

### ORDERING INFORMATION

SERIES	CAPACITY	HOUSING	# OF HEADS	HEAD STYLE LAMP WATTAGE	COLOUR	AC VOLTAGE	OPTIONS
<b>RGS= 6V</b>	<b>36= 36W (S)</b> <b>72= 72W (S)</b> <b>108= 108W (S)</b> <b>180= 180W (L)</b>	<b>TB= T-Bar</b>	<b>Blank= no heads</b> <b>1= one head</b> <b>2= two heads</b> <b>3= three heads</b>	<b>LD1= MR16 LED, 6V-4W</b> <b>LD2= MR16 LED, 6V-5W</b> <b>LD7= MR16 LED, 12V-4W</b> <b>LD9= MR16 LED, 12V-5W</b> <b>LD10= MR16 LED, 12V-6W</b> <b>LD13= MR16 LED, 24V-4W</b> <b>LD14= MR16 LED, 24V-6W</b> <b>130LD1= deco head, MR16 LED, 6V-4W<sup>1</sup></b> <b>130LD2= deco head, MR16 LED, 6V-5W<sup>1</sup></b> <b>130LD7= deco head, MR16 LED, 12V-4W<sup>1</sup></b> <b>130LD9= deco head, MR16 LED, 12V-5W<sup>1</sup></b> <b>130LD10= deco head, MR16 LED, 12V-6W<sup>1</sup></b> <b>130LD13= deco head, MR16 LED, 24V-4W<sup>1</sup></b>	<b>BK= black</b> <b>Blank= factory white</b>	<b>Blank= 120/347 VAC input</b> <b>ZC= 277VAC input</b>	<b>A= ammeter</b> <b>AT= auto-test<sup>1</sup></b> <b>ATN= auto-test (non-audible)<sup>1</sup></b> <b>CT= cab-tire</b> <b>NEXRF= wireless NEXUS<sup>®</sup> system interface<sup>2</sup></b> <b>LD= lamp disconnect (programmable)</b> <b>LTS= light activated test switch</b> <b>T3= time delay (15 minutes)</b> <b>TL= twistlock plug<sup>3</sup></b> <b>TMBB= AC/DC terminal block</b> <b>TMBD= DC terminal block</b> <b>TMBK= AC terminal block</b> <b>V= voltmeter</b>
<b>RG12S= 12V</b>	<b>36= 36W (S)</b> <b>72= 72W (S)</b> <b>100= 100W (S)</b> <b>144= 144W (S)</b> <b>216= 216W (L)</b>						
<b>RG24S= 24V</b>	<b>144= 144W (L)</b> <b>288= 288W (L)</b>						

<sup>1</sup>Polar white or black cabinets only.

<sup>1</sup>Minimum lamp load required: 20% of unit capacity.

<sup>2</sup>Not all options are available with NEXUS<sup>®</sup> system. Please consult your sales representative

<sup>3</sup>120V is standard

EXAMPLE: RGS36TBILD1