

## Nexus<sup>®</sup>Pro Gateway



### Features

- IoT Gateway designed to deliver Bluetooth<sup>®</sup> Mesh connectivity
  - Gateway can be connected wired or wirelessly to WiFi Routers
  - Supports WiFi connections on both 2.4 GHz and 5 GHz frequency bands for added flexibility
  - Communicates with up to 200 emergency units
  - Supplied with a 24 VDC output
  - Suitable for installation indoors in a secure location 0°C to 40°C (32°F to 104°F)
  - ROHS compliant
  - Gateway supplied with a Din-rail that can also be used for wall installation
  - Comes standard with five (5) year warranty
- Warranty details at: [www.tnb.ca/en/brands/emergi-lite](http://www.tnb.ca/en/brands/emergi-lite)**



### Dimensions

Dimensions are approximate and subject to change.

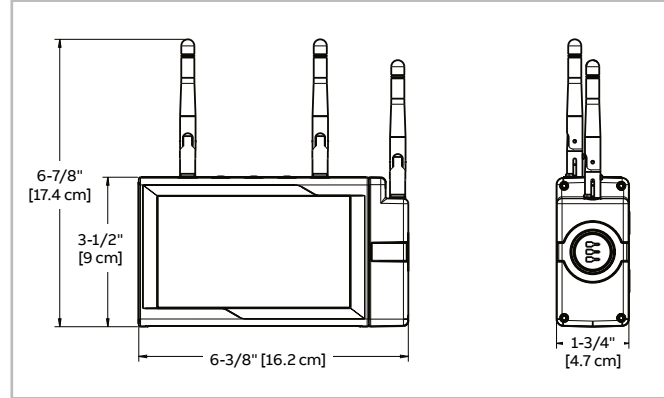

### Weight

Catalog number	Weight
NEXP-GATEWAY-E	1 lb

### Power consumption

Catalog number	Power consumption
NEXP-GATEWAY-E	4W typical, 15W maximum

### Ordering information

Catalog number	Description
NEXP-GATEWAY-E	Nexus <sup>®</sup> Pro IoT Gateway