

New product

ECB-HO Series

Commercial battery unit



Features

- Fully adjustable LED glare-free lens
- 5.4W long life high output LED light source
- Provides 90° spacing at 7.5' mounting height
- Dual voltage input capability 120/347VAC
- Automatic, temperature compensated, pulse type charger
- Low voltage disconnect prevents over discharge of battery
- Automatic brownout protection
- Sealed 9.6V-12W lithium-ion battery offering 90 minutes of emergency lighting
- Battery lock-out prevents discharge during installation
- Red LED charger monitor
- Momentary test switch allows for quick operational check
- Injection-molded thermoplastic ABS housing
- Rear keyhole slots and universal knock-outs to mount to any standard 4" junction box
- Fast and easy installation with snap-together design
- Ceiling or wall mount installation
- Comes standard with one (1) year warranty
- Meets or exceeds CSA C22.2 no.141-15
- **Warranty details at: www.emergi-lite.ca**

Typical specifications

The contractor will install the **Emergi-Lite® ECB-HO LED Series** battery unit.

The emergency lighting system shall consist of fully automatic equipment with two High output LED heads. Each unit shall contain a fully automatic, solid state charger with test switch and AC ON pilot lights.

The unit shall contain a sealed transfer circuit and low voltage disconnect circuit. The battery shall be 9.6V with a capacity of 12W for 90 minutes.

The unit shall be cUL approved to meet CSA 22.2 no. 141-15 standard. The unit shall be **Emergi-Lite®** model: _____.

Dimensions

Dimensions are approximate and subject to change.

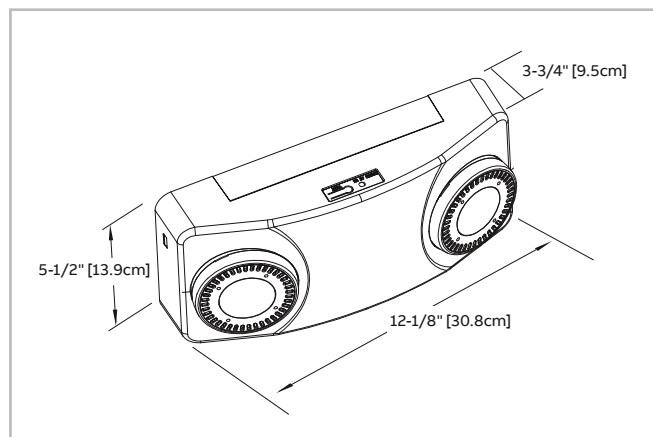

Power consumption and unit rating

Model	AC specs	DC specs
ECB-HO	120/347VAC 0.08 A	0.8 W LifePO Min. 90 minutes

Ordering information

Series	Voltage
ECB-HO= Commercial battery unit high output	Blank= 120/347VAC

Example: ECB-HO