

## JMLA Series

Decorative, 6 and 12V



### Features

- Rugged steel cabinet with corrosion-resistant undercoating
- Removable front panel on cabinet provides easy access and allows unit to be mounted at ceiling height
- Solid-state pulse-type charger – current-limited, temperature-compensated, short-circuit proof and reverse-polarity protected
- Unit comes standard with electronic lockout and brownout circuits
- Sealed dust-proof transfer relay, test switch and LED indicator light(s)
- Long-life, maintenance-free lead acid battery
- NEXUS® compatible. Please consult your sales representative
- CSA C22.2 No. 141 Certified
- **Warranty details at: [www.emergi-lite.ca](http://www.emergi-lite.ca)**

nexus®



### Typical specifications

Supply and install the **Emergi-Lite® JMLA Series** battery units. The battery unit shall come complete with two MR16 emergency lighting heads. The unit shall be rated for dual voltage 120/347V, 60 Hz and shall provide power to the nominal load for at least 30 minutes to 87.5% of the nominal voltage of the battery. The charger shall be factory set with a charging voltage tolerance of  $\pm 1\%$  to enable a longer battery life. The emergency light heads shall be fully adjustable and protected by a clear cover, made of shock-resistant polycarbonate. The protective cover shall be designed to facilitate lamp replacement. The heads shall be installed at the bottom of the unit, providing illumination in any downward direction. The emergency light heads shall require no tools for orientation. The unit cabinet shall be made of steel with anti-corrosion undercoating. The unit equipped with the auto-test diagnostic micro-controller board shall self-test 1 minute every 30 days, 10 minutes the every 6 months and 30 minutes every 12 months. The unit shall be supplied with a test switch and diagnostic LED indicator lights to continuously monitor the status of the unit: Battery Failure, Battery Disconnect, Charger Failure, Lamp Failure, Service Alarm, main voltage AC "ON", Charger High Rate.

The unit shall be CSA Certified to C22.2 no.141.

The unit shall be **Emergi-Lite®** model: \_\_\_\_\_.

### Wire guards

Ordering code	Description
460.0080-E	Wall mount

### Replacement lamps

Ordering code	Type	Voltage/wattage
580.0097-E	MR16 LED	6V-4W
580.0074-E	MR16	6V-6W
580.0079-E	MR16	6V-10W
580.0093-E	MR16 LED	12V-4W
580.0104-E	MR16 LED	12V-5W
580.0106-E	MR16 LED	12V-6W
580.0080-E	MR16	12V-12W
580.0068-E	MR16	12V-20W

Housing colour



Black

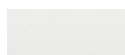

Factory white

## JMLA Series

Decorative, 6 and 12V

### Dimensions

Dimensions are approximate and subject to change.

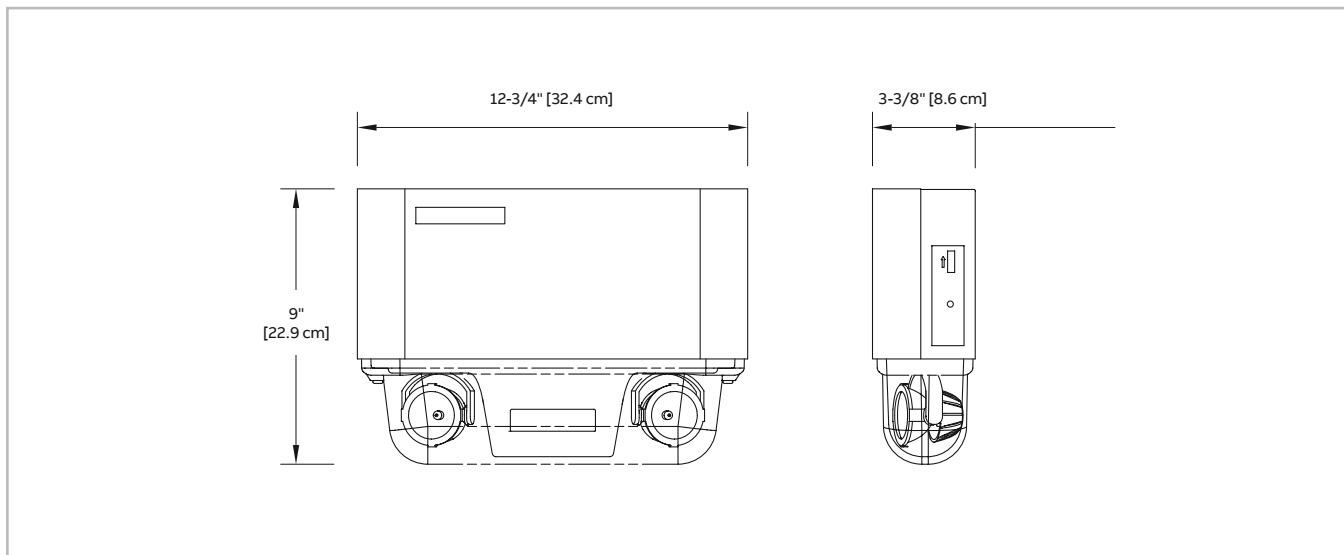

### Power consumption and unit rating

Model	AC specs	Wattage capacity				
		30 min	1H00	1H30	2H00	4H00
06JMLA27	0.06/0.02 A	27	15	11	9	-
06JMLA44	0.18/0.06 A	44	26	18	15	7
06JMLA72	120/347VAC 0.19/0.07 A	72	42	30	24	12
12JMLA44	0.31/0.10 A	44	26	18	15	7
12JMLA72	0.31/0.10 A	72	42	30	24	12

### Ordering information

Series	Capacity	Colour	Voltage	Options	# of heads	Head style/wattage
06JMLA= 6V	27= 27W <sup>1</sup>	BK= black	-2= 277VAC input	Blank= no options	/2= two heads	LA= MR16 LED, 6V-4W
	44= 44W	Blank= factory white	Blank= 120/347VAC	CT= cab-tire		LG= MR16 LED, 12V-4W
	72= 72W			LC= linecord (120V)		LI= MR16 LED, 12V-5W
12JMLA= 12V	44= 44W			LW= twist-lock plug		LJ= MR16 LED, 12V-6W
	72= 72W			NEXRF= wireless NEXUS® system interface <sup>1</sup>		MI= MR16, 6V-6W
				U= auto-diagnostics <sup>1</sup>		MJ= MR16, 6V-10W
				UN= auto-diagnostics, non-audible <sup>1</sup>		MK= MR16, 12V-12W
						MW= MR16-IR, 12V-20W

<sup>1</sup>Not available in 12V

<sup>1</sup>Not available in 6V-72W.

Not all options available with NEXUS® system. Please consult your sales representative.

Example: 12JMLA44UN/2MW