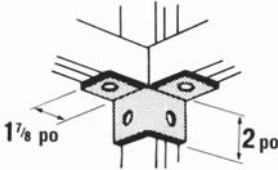
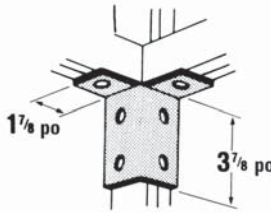
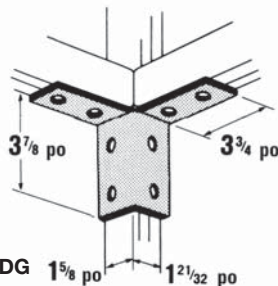
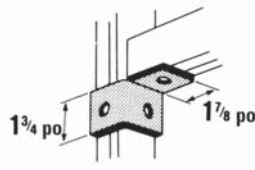
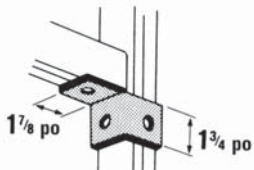
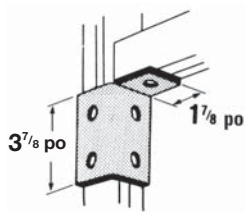
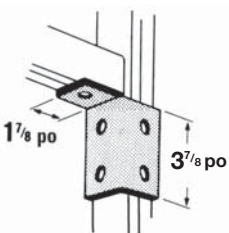
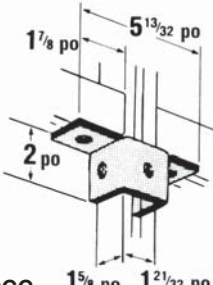
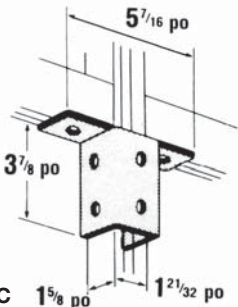
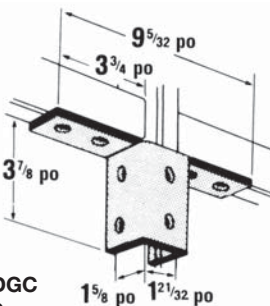
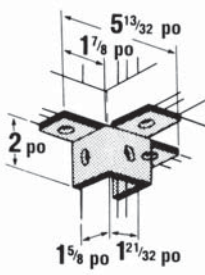
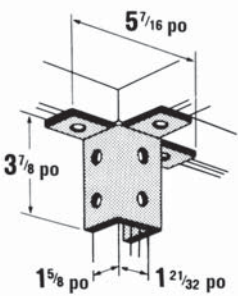
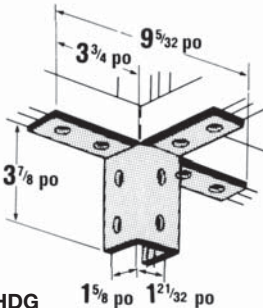

Raccords et supports

SECTION 3

Raccords à ailettes

<p>AW204</p>  <p>AW204HDG AW204EG AW204</p> <p>Poids/100 : 76 lb</p>	<p>AW214</p>  <p>AW214HDG AW214EG AW214</p> <p>Poids/100 : 115 lb</p>	<p>A217</p>  <p>AW217HDG A217EG A217</p> <p>Poids/100 : 155 lb</p>	
<p>AW205L</p>  <p>AW205LHDG AW205LEG AW205L</p>	<p>AW205R</p>  <p>AW205RHDG AW205REG AW205R</p> <p>Poids/100 : 59 lb</p>	<p>AW215L</p>  <p>AW215LHDG AW215LEG AW215L</p>	<p>AW215R</p>  <p>AW215RHDG AW215REG AW215R</p> <p>Poids/100 : 98 lb</p>
<p>AW220</p>  <p>AW220HDGC AW220EG AW220</p> <p>Poids/100 : 90 lb</p>	<p>AW224</p>  <p>AW224HDGC AW224EG AW224</p> <p>Poids/100 : 147 lb</p>	<p>AW219</p>  <p>AW219HDGC AW219EG AW219</p> <p>Poids/100 : 187 lb</p>	
<p>AW226</p>  <p>AW226HDG AW226</p> <p>Poids/100 : 113 lb</p>	<p>A218</p>  <p>A218HDG A218EG A218</p> <p>Poids/100 : 177 lb</p>	<p>AW228</p>  <p>AW228HDG AW228EG AW228</p> <p>Poids/100 : 230 lb</p>	

Matériaux
HDG(C)
EG(C)
(sans suffixe)
SS6(C)

Galvanisation par trempage à chaud
Électrogalvanisé
GoldGalv[™]
Acier inoxydable type 316

Dimensions standard

Espacement des trous
Espacement des trous
Grosueur des trous
Largeur du matériau
Épaisseur du matériau

13/16 po du bout
Entraxe de 1-7/8 po
9/16 po dia.
1-5/8 po
1/4 po