

Exothermic welding system

Earth points

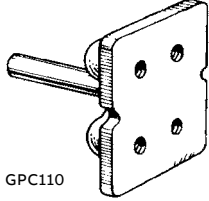

GPC110

Four-hole earth points

Cat. no.	A Hole size (in.)	B (in.)	C (in.)	D (in.)	E (in.)	F (in.)
GPC110	4 x 5/16 UNC x 5/16	27/64	2	3	2 1/2	1 13/32
GPC111	As GPC110 with a pre-welded 20 in. long tail of 2/0 AWG PVC-insulated cable					

Diagrams

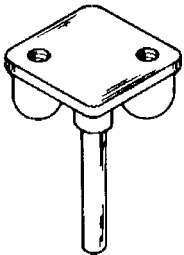
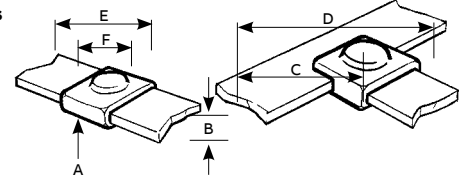

GPC125

Two-hole earth points Complete with front plate

Cat. no.	Conductor type	B (in. dia.)	C (in.)	D (in.)	E (in.)	F (in.)
GPC115	1 in. x 1/8 in. tape or 2/0 AWG cable	27/64	2	3 1/8	2 3/16	1 3/4
GPC116	As GPC115 with a pre-welded 20 in. long tail of 2/0 AWG PVC-insulated cable					
GPC120	1 in. x 1/8 in. tape or 5/16 in. dia. solid	27/64	2	3 1/8	2 3/16	1 3/4
GPC121	As PC120 with a pre-welded 20 in. long tail of 2/0 AWG PVC-insulated cable					

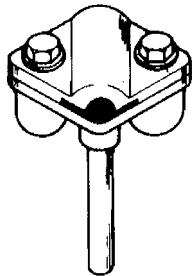

GPC115 - GPC120

Two-hole earth points Without front plate

Cat. no.	Conductor type	B (in. dia.)	C (in.)	D (in.)	E (in.)	F (in.)
GPC125	2 x 5/16 UNC x 1/2	27/64	2	3 1/8	2 3/16	1 3/4
GPC126	As PC125 with a pre-welded 20 in. long tail of 2/0 AWG PVC-insulated cable					

Diagrams

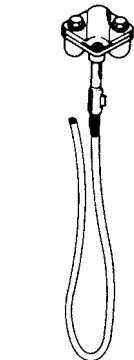
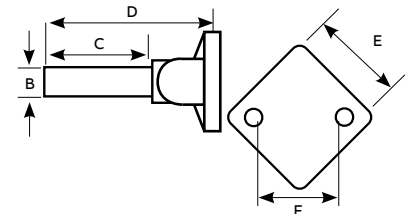

GPC116 - GPC121

Exothermic welding system

Earth points

One-hole earth points

Cat. no.	A hole size	B (in. dia.)	C (in.)	D (in.)	E (in.)
GPC100	1 x $\frac{5}{16}$ UNC x $\frac{5}{8}$	$\frac{27}{64}$	$2\frac{3}{16}$	$3\frac{3}{8}$	$1\frac{3}{8}$
GPC101	1 x $\frac{3}{8}$ UNC x $\frac{5}{8}$	$\frac{27}{64}$	$2\frac{3}{16}$	$3\frac{3}{8}$	$1\frac{3}{8}$
GPC105	As PC100 with a pre-welded 20 in. long tail of 2/0 AWG PVC-insulated cable				
GPC106	As PC101 with a pre-welded 20 in. long tail of 2/0 AWG PVC-insulated cable				

Diagrams

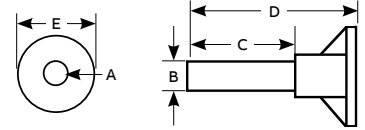

GRX005

Static earth receptacle

Cat. no.	B (in. dia.)	C (in.)	D (in.)	E (in.)
GRX005	$\frac{27}{64}$	$1\frac{1}{2}$	$3\frac{3}{8}$	$2\frac{11}{16}$

Diagram

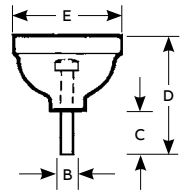

Exothermic welding system

CCI cable to cable

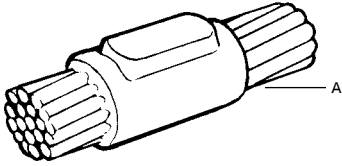

- Stranded conductor
- Solid circular conductor

—
CCI

Cat. no.	Wire size (A) (AWG or kcmil)	Welding powder size	Handle clamp type	Std. qty.
CC1-3-#3	#3	32BKB	HCPK3	1
CC1-3-#2	#2	32BKB	HCPK3	1
CC1-3-#2S	#2 solid	32BKB	HCPK3	1
CC1-3-#1	#1	32BKB	HCPK3	1
CC1-3-#1S	#1 solid	32BKB	HCPK3	1
CC1-4-1/0	1/0	45BKB	HCPK4	1
CC1-4-1/0S	1/0 solid	45BKB	HCPK4	1
CC1-4-2/0	2/0	65BKB	HCPK4	1
CC1-4-3/0	3/0	90BKB	HCPK4	1
CC1-4-4/0	4/0	90BKB	HCPK4	1
CC1-4-4/0S	4/0 solid	90BKB	HCPK4	1
CC1-4-250K	250	115BKB	HCPK4	1
CC1-4-300K	300	115BKB	HCPK4	1
CC1-4-350K	350	150BKB	HCPK4	1
CC1-4-500K	500	200BKB	HCPK4	1
CC1-5-750K	750	2 X 150BKB	HCPK5	1
CC1-5-1000K	1,000	2 X 200BKB	HCPK5	1

Exothermic welding system

CC2 cable to cable

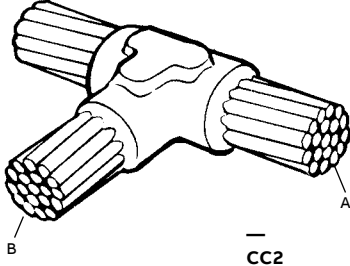

- Stranded conductor
- Solid circular conductor

Cat. no.	Wire size (AWG or kcmil)		Welding powder size	Handle clamp type	Std. qty.
	A	B			
CC2-4-#4#4	4	4	32BKB	HCPK4	1
CC2-4-#2S#2	#2 solid	#2	45BKB	HCPK4	1
CC2-4-#2S#2S	#2 solid	#2 solid	45BKB	HCPK4	1
CC2-4-#2S#4	#2 solid	#4	45BKB	HCPK4	1
CC2-4-#2#2	#2	#2	45BKB	HCPK4	1
CC2-4-#2#2S	#2	#2 solid	45BKB	HCPK4	1
CC2-4-#2#4	#2	#4	45BKB	HCPK4	1
CC2-4-#1#1	#1	#1	45BKB	HCPK4	1
CC2-4-#1#2	#1	#2	45BKB	HCPK4	1
CC2-4-#1#2S	#1	#2 solid	45BKB	HCPK4	1
CC2-4-#1#4	#1	#4	45BKB	HCPK4	1
CC2-4-1/01/0	1/0	1/0	90BKB	HCPK4	1
CC2-4-1/0#1	1/0	#1	45BKB	HCPK4	1
CC2-4-1/0#2	1/0	#2	45BKB	HCPK4	1
CC2-4-1/0#2S	1/0	#2 solid	45BKB	HCPK4	1
CC2-4-1/0#4	1/0	#4	45BKB	HCPK4	1
CC2-4-2/02/0	2/0	2/0	90BKB	HCPK4	1
CC2-4-2/01/0	2/0	1/0	90BKB	HCPK4	1
CC2-4-2/0#1	2/0	#1	45BKB	HCPK4	1
CC2-4-2/0#2	2/0	#2	45BKB	HCPK4	1
CC2-4-2/0#2S	2/0	2 solid	45BKB	HCPK4	1
CC2-4-2/0#4	2/0	#4	45BKB	HCPK4	1
CC2-4-3/03/0	3/0	3/0	115BKB	HCPK4	1
CC2-4-3/02/0	3/0	2/0	90BKB	HCPK4	1
CC2-4-3/01/0	3/0	1/0	90BKB	HCPK4	1
CC2-4-3/0#1	3/0	#1	45BKB	HCPK4	1

Cat. no.	Wire size (AWG or kcmil)		Welding powder size	Handle clamp type	Std. qty.
	A	B			
CC2-4-3/0#2	3/0	#2	45BKB	HCPK4	1
CC2-4-3/0#2S	3/0	#2 solid	45BKB	HCPK4	1
CC2-4-3/0#4	3/0	#4	45BKB	HCPK4	1
CC2-4-4/04/0	4/0	4/0	150BKB	HCPK4	1
CC2-4-4/03/0	4/0	3/0	115BKB	HCPK4	1
CC2-4-4/02/0	4/0	2/0	90BKB	HCPK4	1
CC2-4-4/01/0	4/0	1/0	90BKB	HCPK4	1
CC2-4-4/0#1	4/0	#1	90BKB	HCPK4	1
CC2-4-4/0#2	4/0	#2	90BKB	HCPK4	1
CC2-4-4/0#2S	4/0	#2 solid	90BKB	HCPK4	1
CC2-4-4/0#4	4/0	#4	90BKB	HCPK4	1
CC2-4-250K250K	250	250	150BKB	HCPK4	1
CC2-4-250K4/0	250	4/0	150BKB	HCPK4	1
CC2-4-250K4/0	250	3/0	150BKB	HCPK4	1
CC2-4-250K2/0	250	2/0	90BKB	HCPK4	1
CC2-4-250K1/0	250	1/0	90BKB	HCPK4	1
CC2-4-250K#1	250	#1	90BKB	HCPK4	1
CC2-4-250K#2	250	#2	90BKB	HCPK4	1
CC2-4-250K#2S	250	#2 solid	90BKB	HCPK4	1
CC2-4-250K#4	250	#4	90BKB	HCPK4	1
CC2-4-300K300K	300	300	200BKB	HCPK4	1
CC2-4-300K250K	300	250	150BKB	HCPK4	1
CC2-4-300K4/0	300	4/0	150BKB	HCPK4	1
CC2-4-300K3/0	300	3/0	150BKB	HCPK4	1
CC2-4-300K2/0	300	2/0	90BKB	HCPK4	1
CC2-4-300K1/0	300	1/0	90BKB	HCPK4	1

Exothermic welding system

CC2 cable to cable

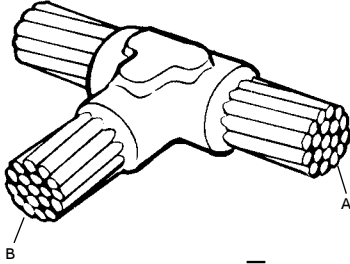

- Stranded conductor
- Solid circular conductor

CC2 (cont'd)

Cat. no.	Wire size (AWG or kcmil)		Welding powder size	Handle clamp type	Std. qty.
	A	B			
CC2-4-300K#2	300	#2	90BKB	HCPK4	1
CC2-4-300K#2S	300	#2 solid	90BKB	HCPK4	1
CC2-4-300K#4	300	#4	90BKB	HCPK4	1
CC2-4-350K350K	350	350	200BKB	HCPK4	1
CC2-4-350K300K	350	300	200BKB	HCPK4	1
CC2-4-350K250K	350	250	200BKB	HCPK4	1
CC2-4-350K4/0	350	4/0	150BKB	HCPK4	1
CC2-4-350K3/0	350	3/0	150BKB	HCPK4	1
CC2-4-350K2/0	350	2/0	90BKB	HCPK4	1
CC2-4-350K1/0	350	1/0	90BKB	HCPK4	1
CC2-4-350K#1	350	#1	90BKB	HCPK4	1
CC2-4-350K#2	350	#2	90BKB	HCPK4	1
CC2-4-350K#4	350	#4	90BKB	HCPK4	1
CC2-4-500K500K	500	500	2 X 150BKB	HCPK4	1
CC2-4-500K350K	500	350	200BKB	HCPK4	1
CC2-4-500K300K	500	300	200BKB	HCPK4	1
CC2-4-500K250K	500	250	200BKB	HCPK4	1
CC2-4-500K4/0	500	4/0	150BKB	HCPK4	1
CC2-4-500K2/0	500	2/0	90BKB	HCPK4	1
CC2-4-500K1/0	500	1/0	90BKB	HCPK4	1
CC2-4-500K#1	500	#1	90BKB	HCPK4	1
CC2-4-500K#2	500	#2	90BKB	HCPK4	1
CC2-4-500K#4	500	#4	90BKB	HCPK4	1
CC2-5-750K750K	750	750	2 X 250BKB	HCPK5	1
CC2-5-750K500K	750	500	2 X 250BKB	HCPK5	1
CC2-4-750K350K	750	350	250BKB	HCPK4	1

Cat. no.	Wire size (AWG or kcmil)		Welding powder size	Handle clamp type	Std. qty.
	A	B			
CC2-4-750K300K	750	300	200BKB	HCPK4	1
CC2-4-750K250	750	250	200BKB	HCPK4	1
CC2-4-750K4/0	750	4/0	150BKB	HCPK4	1
CC2-4-750K2/0	750	2/0	150BKB	HCPK4	1
CC2-4-750K1/0	750	1/0	150BKB	HCPK4	1
CC2-5-1000K1000K	1,000	1,000	2 X 250BKB	HCPK5	1
CC2-5-1000K750K	1,000	750	2 X 250BKB	HCPK5	1
CC2-5-1000K500K	1,000	500	2 X 200BKB	HCPK5	1
CC2-4-1000K350K	1,000	350	250BKB	HCPK4	1
CC2-4-1000K300K	1,000	300	200BKB	HCPK4	1
CC2-4-1000K250K	1,000	250	200BKB	HCPK4	1
CC2-4-1000K4/0	1,000	4/0	150BKB	HCPK4	1
CC2-4-1000K2/0	1,000	2/0	150BKB	HCPK4	1
CC2-4-1000K1/0	1,000	1/0	150BKB	HCPK4	1

Exothermic welding system

CC4 cable to cable

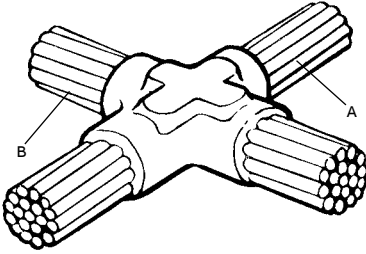

CC4

Cat. no.	Wire size (AWG or kcmil)		Welding powder size	Handle clamp type	Std. qty.
	A	B			
CC4-4-#4#4	#4	#4	45BKB	HCPK4	1
CC4-4-#2#2	#2	#2	65BKB	HCPK4	1
CC4-4-#2#4	#2	#4	65BKB	HCPK4	1
CC4-4-#2S#2S	2 solid	2 solid	2 massif	HCPK4	1
CC4-4-#1#1	#1	#1	65BKB	HCPK4	1
CC4-4-#1#2	#1	#2	65BKB	HCPK4	1
CC4-4-#1#4	#1	#4	65BKB	HCPK4	1
CC4-4-1/01/0	1/0	1/0	90BKB	HCPK4	1
CC4-4-1/0#1	1/0	#1	90BKB	HCPK4	1
CC4-4-1/0#2	1/0	#2	90BKB	HCPK4	1
CC4-4-1/0#4	1/0	#4	90BKB	HCPK4	1
CC4-4-2/02/0	2/0	2/0	115BKB	HCPK4	1
CC4-42/01/0	2/0	1/0	115BKB	HCPK4	1
CC4-4-2/0#1	2/0	#1	115BKB	HCPK4	1
CC4-4-2/0#2	2/0	#2	115BKB	HCPK4	1
CC4-4-3/03/0	3/0	3/0	115BKB	HCPK4	1
CC4-4-3/02/0	3/0	2/0	150BKB	HCPK4	1
CC4-4-3/01/0	3/0	1/0	115BKB	HCPK4	1
CC4-4-3/0#1	3/0	#1	115BKB	HCPK4	1
CC4-4-3/0#2	3/0	#2	115BKB	HCPK4	1
CC4-4-4/04/0	4/0	4/0	200BKB	HCPK4	1
CC4-4-4/03/0	4/0	3/0	200BKB	HCPK4	1
CC4-4-4/02/0	4/0	2/0	150BKB	HCPK4	1
CC4-4-4/01/0	4/0	1/0	150BKB	HCPK4	1
CC4-4-4/0#1	4/0	#1	115BKB	HCPK4	1
CC4-4-4/0#2	4/0	#2	115BKB	HCPK4	1
CC4-4-250K250K	250	250	200BKB	HCPK4	1
CC4-4-250K4/0	250	4/0	200BKB	HCPK4	1
CC4-4-250K3/0	250	3/0	200BKB	HCPK4	1
CC4-4-250K2/0	250	2/0	150BKB	HCPK4	1
CC4-4-250K1/0	250	1/0	150BKB	HCPK4	1
CC4-4-250K#1	250	#1	115BKB	HCPK4	1
CC4-4-250K#2	250	#2	115BKB	HCPK4	1

- Stranded conductor
- Solid circular conductor

Cat. no.	Wire size (AWG or kcmil)		Welding powder size	Handle clamp type	Std. qty.
	A	B			
CC4-4-300K300K	300	300	250BKB	HCPK4	1
CC4-4-300K250K	300	250	250BKB	HCPK4	1
CC4-4-300K4/0	300	4/0	200BKB	HCPK4	1
CC4-4-300K3/0	300	3/0	200BKB	HCPK4	1
CC4-4-300K2/0	300	2/0	150BKB	HCPK4	1
CC4-4-300K1/0	300	1/0	150BKB	HCPK4	1
CC4-4300K#1	300	#1	115BKB	HCPK4	1
CC4-4-300K#2	300	#2	115BKB	HCPK4	1
CC4-4-350K350K	350	350	250BKB	HCPK4	1
CC4-4-350K300K	350	300	250BKB	HCPK4	1
CC4-4-4350K250K	350	250	250BKB	HCPK4	1
CC4-4-350K4/0	350	4/0	200BKB	HCPK4	1
CC4-4-350K3/0	350	3/0	200BKB	HCPK4	1
CC4-350K2/0	350	2/0	200BKB	HCPK4	1
CC4-4-350K1/0	350	1/0	200BKB	HCPK4	1
CC4-4-350K#1	350	#1	150BKB	HCPK4	1
CC4-4-350K#2	350	#2	150BKB	HCPK4	1
CC4-5-500K500K	500	500	2 X 250BKB	HCPK5	1
CC4-5-500K350K	500	350	2 X 200BKB	HCPK5	1
CC4-5-500K300K	500	300	2 X 200BKB	HCPK5	1
CC4-5-500K250K	500	250	2 X 150BKB	HCPK5	1
CC4-5-500K4/0	500	4/0	2 X 150BKB	HCPK5	1
CC4-5-500K3/0	500	3/0	2 X 150BKB	HCPK5	1
CC4-4-500K2/0	500	2/0	250BKB	HCPK5	1
CC4-4-500K1/0	500	1/0	250BKB	HCPK5	14

Exothermic welding system

CC6 cable to cable

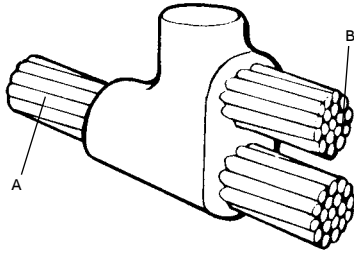

CC6

- Stranded conductor
- Solid circular conductor

Cat. no.	Wire size (AWG or kcmil)		Welding powder size	Handle clamp type	Std. qty.
	A	B			
CC6-4-#4#4	#4	#4	45BKB	HCPK4	1
CC6-4-#2#2	#2	#2	65BKB	HCPK4	1
CC6-4-#2#4	#2	#4	65BKB	HCPK4	1
CC6-4-#2S#2S	2 solid	2 solid	65BKB	HCPK4	1
CC6-4-#1#1	#1	#1	65BKB	HCPK4	1
CC6-4-#1#2	#1	#2	65BKB	HCPK4	1
CC6-4-#1#4	#1	#4	65BKB	HCPK4	1
CC6-4-1/01/0	1/0	1/0	90BKB	HCPK4	1
CC6-4-1/0#1	1/0	#1	90BKB	HCPK4	1
CC6-4-1/0#2	1/0	#2	90BKB	HCPK4	1
CC6-4-1/0#4	1/0	#4	90BKB	HCPK4	1
CC6-4-2/02/0	2/0	2/0	115BKB	HCPK4	1
CC6-4-2/01/0	2/0	1/0	115BKB	HCPK4	1
CC6-4-2/0#1	2/0	#1	115BKB	HCPK4	1
CC6-4-2/0#2	2/0	#2	115BKB	HCPK4	1
CC6-4-3/03/0	3/0	3/0	115BKB	HCPK4	1
CC6-4-3/02/0	3/0	2/0	150BKB	HCPK4	1
CC6-4-3/01/0	3/0	1/0	115BKB	HCPK4	1
CC6-4-3/0#1	3/0	#1	115BKB	HCPK4	1
CC6-4-3/0#2	3/0	#2	115BKB	HCPK4	1
CC6-4-4/04/0	4/0	4/0	200BKB	HCPK4	1
CC6-4-4/03/0	4/0	3/0	200BKB	HCPK4	1
CC6-4-4/02/0	4/0	2/0	150BKB	HCPK4	1
CC6-4-4/01/0	4/0	1/0	150BKB	HCPK4	1
CC6-4-4/0#1	4/0	#1	115BKB	HCPK4	1
CC6-4-4/0#2	4/0	#2	115BKB	HCPK4	1

Cat. no.	Wire size (AWG or kcmil)		Welding powder size	Handle clamp type	Std. qty.
	A	B			
CC6-4-250K250K	250	250	200BKB	HCPK4	1
CC6-4-250K4/0	250	4/0	200BKB	HCPK4	1
CC6-4-250K3/0	250	3/0	200BKB	HCPK4	1
CC6-4-250K2/0	250	2/0	150BKB	HCPK4	1
CC6-4-250K1/0	250	1/0	150BKB	HCPK4	1
CC6-4-250K#1	250	#1	115BKB	HCPK4	1
CC6-4-250K#2	250	#2	115BKB	HCPK4	1
CC6-4-300K300K	300	300	250BKB	HCPK4	1
CC6-4-300K250K	300	250	250BKB	HCPK4	1
CC6-4-300K4/0	300	4/0	200BKB	HCPK4	1
CC6-4-300K3/0	300	3/0	200BKB	HCPK4	1
CC6-4-300K2/0	300	2/0	150BKB	HCPK4	1
CC6-4-300K1/0	300	1/0	150BKB	HCPK4	1
CC6-4-300K#1	300	#1	115BKB	HCPK4	1
CC6-4-300K#2	300	#2	115BKB	HCPK4	1
CC6-4-350K350K	350	350	250BKB	HCPK4	1
CC6-4-350K300K	350	300	250BKB	HCPK4	1
CC6-4-4350K250K	350	250	250BKB	HCPK4	1
CC6-4-350K4/0	350	4/0	200BKB	HCPK4	1
CC6-4-350K3/0	350	3/0	200BKB	HCPK4	1
CC6-4-350K2/0	350	2/0	200BKB	HCPK4	1

Exothermic welding system

CC7 cable to cable

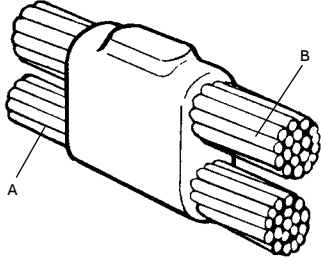

- Stranded conductor
- Solid circular conductor

CC7

Cat. no.	Wire size (AWG or kcmil)		Welding powder size	Handle clamp type	Sleeve	Std. qty.
	A	B				
CC7-4-#4#4	#4	#4	32BKB	HCPK4	-	1
CC7-4-#4#6	#4	#6	32BKB	HCPK4	2 X Sleeve#6	1
CC7-4-#4#6S	#4	#6 solid	32BKB	HCPK4	2 X Sleeve#6S	1
CC7-4-#4#8	#4	#8	32BKB	HCPK4	2 X Sleeve#8	1
CC7-4-#2S#2	#2 solid	#2	65BKB	HCPK4	-	1
CC7-4-#2S#2S	#2 solid	#2 solid	65BKB	HCPK4	-	1
CC7-4-#2S#4	#2 solid	#4	65BKB	HCPK4	-	1
CC7-4-#2S#6	#2 solid	#6	45BKB	HCPK4	2 X Sleeve#6	1
CC7-4-#2S#6S	#2 solid	#6 solid	45BKB	HCPK4	2 X Sleeve#6S	1
CC7-4-#2S#8	#2 solid	#8	45BKB	HCPK4	2 X Sleeve#8	1
CC7-4-#2S#8S	#2 solid	#8 solid	8 solid	HCPK4	2 X Sleeve#8S	1
CC7-4-#2#2	#2	#2	65BKB	HCPK4	-	1
CC7-4-#2#4	#2	#4	65BKB	HCPK4	-	1
CC7-4-#2#6	#2	#6	45BKB	HCPK4	2 X Sleeve#6	1
CC7-4-#2#6S	#2	#6 solid	45BKB	HCPK4	2 X Sleeve#6S	1
CC7-4-#2#8	#2	#8	45BKB	HCPK4	2 X Sleeve#8	1
CC7-4-#2#8S	#2	#8 solid	45BKB	HCPK4	2 X Sleeve#8S	1
CC7-4-#1S#1	#1 solid	#1	65BKB	HCPK4	-	1
CC7-4-#1S#2	#1 solid	#2	65BKB	HCPK4	-	1
CC7-4-#1S#2S	#1 solid	#2 solid	65BKB	HCPK4	-	1
CC7-4-#1S#4	#1 solid	#4	65BKB	HCPK4	-	1
CC7-4-#1S#6	#1 solid	#6	65BKB	HCPK4	2 X Sleeve#6	1
CC7-4-#1S#6S	#1 solid	#6 solid	65BKB	HCPK4	2 X Sleeve#6S	1
CC7-4-#1S#8	#1 solid	#8	45BKB	HCPK4	2 X Sleeve#8	1
CC7-4-#1S#8S	#1 solid	#8 solid	45BKB	HCPK4	2 X Sleeve#8S	1
CC7-4-#1#1	#1	#1	65BKB	HCPK4	-	1
CC7-4-#1#1S	#1	#1 solid	65BKB	HCPK4	-	1
CC7-4-#1#2	#1	#2	65BKB	HCPK4	-	1
CC7-4-#1#2S	#1	#2 solid	65BKB	HCPK4	-	1
CC7-4-#1#4	#1	#4	65BKB	HCPK4	-	1
CC7-4-#1#6	#1	#6	65BKB	HCPK4	2 X Sleeve#6	1
CC7-4-#1#6S	#1	#6 solid	65BKB	HCPK4	2 X Sleeve#6S	1
CC7-4-#1#8	#1	#8	45BKB	HCPK4	2 X Sleeve#8	1
CC7-4-#1#8S	#1	#8 solid	45BKB	HCPK4	2 X Sleeve#8S	1
CC7-4-1/0S1/0	1/0 solid	1/0	90BKB	HCPK4	-	1
CC7-4-1/0S1/0S	1/0 solid	1/0 solid	90BKB	HCPK4	-	1
CC7-4-1/0S#1	1/0 solid	#1	65BKB	HCPK4	-	1
CC7-4-1/0S#1S	1/0 solid	#1 solid	65BKB	HCPK4	-	1
CC7-4-1/0S#2	1/0 solid	#2	65BKB	HCPK4	-	1
CC7-4-1/0S#2S	1/0 solid	#2 solid	65BKB	HCPK4	-	1
CC7-4-1/0S#4	1/0 solid	#4	65BKB	HCPK4	-	1
CC7-4-1/0S#6	1/0 solid	#6	65BKB	HCPK4	2 X Sleeve#6	1
CC7-4-1/0S#6S	1/0 solid	#6 solid	65BKB	HCPK4	2 X Sleeve#6S	1
CC7-4-1/0S#8	1/0 solid	#8	65BKB	HCPK4	2 X Sleeve#8	1
CC7-4-1/0S#8S	1/0 solid	#8 solid	65BKB	HCPK4	2 X Sleeve#8S	1
CC7-4-1/01/0	1/0	1/0	90BKB	HCPK4	-	1
CC7-4-1/01/0S	1/0	1/0 solid	90BKB	HCPK4	-	1

Exothermic welding system

CC7 cable to cable

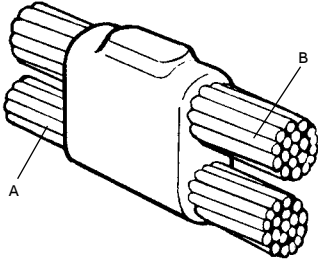

- Stranded conductor
- Solid circular conductor

CC7 (cont'd)

Cat. no.	Wire size (AWG or kcmil)		Welding powder size	Handle clamp type	Sleeve	Std. qty.
	A	B				
CC7-4-1/0#1	1/0	#1	65BKB	HCPK4	-	1
CC7-4-1/0#1S	1/0	#1 solid	65BKB	HCPK4	-	1
CC7-4-1/0#2	1/0	#2	65BKB	HCPK4	-	1
CC7-4-1/0#2S	1/0	#2 solid	65BKB	HCPK4	-	1
CC7-4-1/0#4	1/0	#4	65BKB	HCPK4	-	1
CC7-4-1/0#6	1/0	#6	65BKB	HCPK4	2 X Sleeve#6	1
CC7-4-1/0#6S	1/0	#6 solid	65BKB	HCPK4	2 X Sleeve#6S	1
CC7-4-1/0#8	1/0	#8	65BKB	HCPK4	2 X Sleeve#8	1
CC7-4-1/0#8S	1/0	#8 solid	65BKB	HCPK4	2 X Sleeve#8S	1
CC7-4-2/02/0	2/0	2/0	115BKB	HCPK4	-	1
CC7-4-2/01/0	2/0	1/0	115BKB	HCPK4	-	1
CC7-4-2/01/0S	2/0	1/0 solid	115BKB	HCPK4	-	1
CC7-4-2/0#1	2/0	#1	90BKB	HCPK4	-	1
CC7-4-2/0#1S	2/0	#1 solid	90BKB	HCPK4	-	1
CC7-4-2/0#2	2/0	#2	90BKB	HCPK4	-	1
CC7-4-2/0#4	2/0	#4	90BKB	HCPK4	-	1
CC7-4-2/0#6	2/0	#6	90BKB	HCPK4	2 X Sleeve#6	1
CC7-4-2/0#6S	2/0	#6 solid	90BKB	HCPK4	2 X Sleeve#6S	1
CC7-4-2/0#8	2/0	#8	65BKB	HCPK4	2 X Sleeve#8	1
CC7-4-2/0#8S	2/0	#8 solid	65BKB	HCPK4	2 X Sleeve#8S	1
CC7-4-3/03/0	3/0	3/0	150BKB	HCPK4	-	1
CC7-4-3/02/0	3/0	2/0	150BKB	HCPK4	-	1
CC7-4-3/01/0	3/0	1/0	115BKB	HCPK4	-	1
CC7-4-3/01/0S	3/0	1/0 solid	115BKB	HCPK4	-	1
CC7-4-3/0#1	3/0	#1	115BKB	HCPK4	-	1
CC7-4-3/0#1S	3/0	#1 solid	115BKB	HCPK4	-	1
CC7-4-3/0#2	3/0	#2	115BKB	HCPK4	-	1
CC7-4-3/0#2S	3/0	#2 solid	115BKB	HCPK4	-	1
CC7-4-3/0#4	3/0	#4	115BKB	HCPK4	-	1
CC7-4-3/0#6	3/0	#6	90BKB	HCPK4	2 X Sleeve#6	1
CC7-4-3/0#6S	3/0	#6 solid	90BKB	HCPK4	2 X Sleeve#6S	1
CC7-4-3/0#8	3/0	#8	90BKB	HCPK4	2 X Sleeve#8	1
CC7-4-3/0#8S	3/0	#8 solid	90BKB	HCPK4	2 X Sleeve#8S	1

Exothermic welding system

CC7 cable to cable

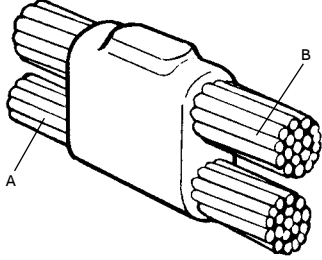

- Stranded conductor
- Solid circular conductor

CC7 (cont'd)

Cat. no.	Wire size (AWG or kcmil)		Welding powder size	Handle clamp type	Sleeve	Std. qty.
	A	B				
CC7-4-4/0S4/0	4/0 solid	4/0	200BKB	HCPK4	-	1
CC7-4-4/0S4/0S	4/0 solid	4/0 solid	200BKB	HCPK4	-	1
CC7-4-4/0S3/0	4/0 solid	3/0	200BKB	HCPK4	-	1
CC7-4-4/0S2/0	4/0 solid	2/0	150BKB	HCPK4	-	1
CC7-4-4/0S1/0	4/0 solid	1/0	150BKB	HCPK4	-	1
CC7-4-4/0S1/0S	4/0 solid	1/0 solid	150BKB	HCPK4	-	1
CC7-4-4/0S#1	4/0 solid	#1	150BKB	HCPK4	-	1
CC7-4-4/0S#1S	4/0 solid	#1 solid	150BKB	HCPK4	-	1
CC7-4-4/0S#2	4/0 solid	#2	150BKB	HCPK4	-	1
CC7-4-4/0S#2S	4/0 solid	#2 solid	150BKB	HCPK4	-	1
CC7-4-4/0S#4	4/0 solid	#4	150BKB	HCPK4	-	1
CC7-4-4/0S#6	4/0 solid	#6	90BKB	HCPK4	2 X Sleeve#6	1
CC7-4-4/0S#6S	4/0 solid	#6 solid	90BKB	HCPK4	2 X Sleeve#6S	1
CC7-4-4/0S#8	4/0 solid	#8	90BKB	HCPK4	2 X Sleeve#8	1
CC7-4-4/0S#8S	4/0 solid	#8 solid	90BKB	HCPK4	2 X Sleeve#8S	1
CC7-4-4/04/0	4/0	4/0	200BKB	HCPK4	-	1
CC7-4-4/04/0S	4/0	4/0 solid	200BKB	HCPK4	-	1
CC7-4-4/03/0	4/0	3/0	200BKB	HCPK4	-	1
CC7-4-4/02/0	4/0	2/0	150BKB	HCPK4	-	1
CC7-4-4/01/0	4/0	1/0	150BKB	HCPK4	-	1
CC7-4-4/01/0S	4/0	1/0 solid	150BKB	HCPK4	-	1
CC7-4-4/0#1	4/0	#1	150BKB	HCPK4	-	1
CC7-4-4/0#1S	4/0	#1 solid	150BKB	HCPK4	-	1
CC7-4-4/0#2	4/0	#2	150BKB	HCPK4	-	1
CC7-4-4/0#2S	4/0	#2 solid	150BKB	HCPK4	-	1
CC7-4-4/0#4	4/0	#4	150BKB	HCPK4	-	1
CC7-4-4/0#6	4/0	#6	90BKB	HCPK4	2 X Sleeve#6	1
CC7-4-4/0#6S	4/0	#6 solid	90BKB	HCPK4	2 X Sleeve#6S	1
CC7-4-4/0#8	4/0	#8	90BKB	HCPK4	2 X Sleeve#8	1
CC7-4-4/0#8S	4/0	#8 solid	90BKB	HCPK4	2 X Sleeve#8S	1

Exothermic welding system

CC11 cable to cable

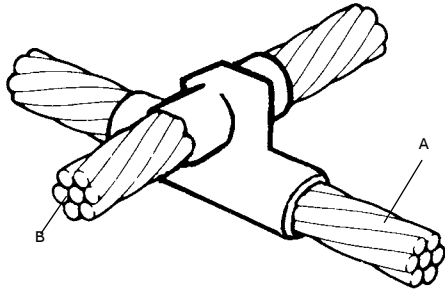

- Stranded conductor
- Solid circular conductor

CC11

Cat. no.	Wire size (AWG or kcmil)		Welding powder size	Handle clamp type	Sleeve	Std. qty.
	A	B				
CC11-7-#6S#6S	#6 solid	#6 solid	32BKB	HCPK7	4 X Sleeve#6S	1
CC11-7-#6#6	#6	#6	45BKB	HCPK7	4 X Sleeve#6	1
CC11-7-#4#4	#4	#4	65BKB	HCPK7	-	1
CC11-7-#2#2	#2	#2	90BKB	HCPK7	-	1
CC11-7-#2#4	#2	#4	65BKB	HCPK7	-	1
CC11-7-#2S#2S	#2 solid	#2 solid	90BKB	HCPK7	-	1
CC11-7-#1#1	#1	#1	115BKB	HCPK7	-	1
CC11-7-#1#2	#1	#2	90BKB	HCPK7	-	1
CC11-7-#1#4	#1	#4	90BKB	HCPK7	-	1
CC11-7-1/01/0	1/0	1/0	150BKB	HCPK7	-	1
CC11-7-1/0#1	1/0	#1	150BKB	HCPK7	-	1
CC11-7-1/0#2	1/0	#2	115BKB	HCPK7	-	1
CC11-7-1/0#4	1/0	#4	115BKB	HCPK7	-	1
CC11-7-2/02/0	2/0	2/0	200BKB	HCPK7	-	1
CC11-7-2/01/0	2/0	1/0	200BKB	HCPK7	-	1
CC11-7-2/0#1	2/0	#1	150BKB	HCPK7	-	1
CC11-7-2/0#2	2/0	#2	150BKB	HCPK7	-	1
CC11-7-3/03/0	3/0	3/0	250BKB	HCPK7	-	1
CC11-7-3/02/0	3/0	2/0	200BKB	HCPK7	-	1
CC11-7-3/01/0	3/0	1/0	200BKB	HCPK7	-	1
CC11-7-3/0#1	3/0	#1	150BKB	HCPK7	-	1
CC11-7-3/0#2	3/0	#2	150BKB	HCPK7	-	1
CC11-7-4/04/0	4/0	4/0	250BKB	HCPK7	-	1
CC11-7-4/03/0	4/0	3/0	250BKB	HCPK7	-	1
CC11-7-4/02/0	4/0	2/0	200BKB	HCPK7	-	1
CC11-7-4/01/0	4/0	1/0	200BKB	HCPK7	-	1
CC11-7-4/0#1	4/0	#1	150BKB	HCPK7	-	1
CC11-7-4/0#2	4/0	#2	150BKB	HCPK7	-	1
CC11-7-250K250K	250	250	2 X 150BKB	HCPK7	-	1
CC11-7-250K4/0	250	4/0	2 X 150BKB	HCPK7	-	1
CC11-7-250K3/0	250	3/0	2 X 150BKB	HCPK7	-	1
CC11-7-250K2/0	250	2/0	250BKB	HCPK7	-	1
CC11-7-250K1/0	250	1/0	250BKB	HCPK7	-	1
CC11-7-250K#1	250	#1	200BKB	HCPK7	-	1
CC11-7-250K#2	250	#2	150BKB	HCPK7	-	1

Exothermic welding system

CC11 cable to cable

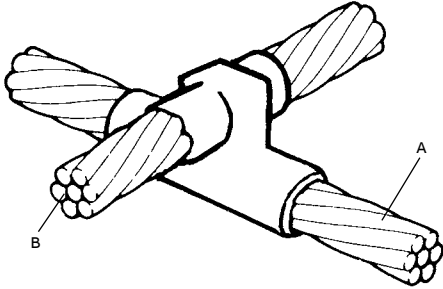

- Stranded conductor
- Solid circular conductor

CC11 (cont'd)

Cat. no.	Wire size (AWG or kcmil)		Welding powder size	Handle clamp type	Sleeve	Std. qty.
	A	B				
CC11-8-300K300K	300	300	2 X 200BKB	HCPK8	-	1
CC11-8-300K250K	300	250	2 X 200BKB	HCPK8	-	1
CC11-7-300K4/0	300	4/0	2 X 150BKB	HCPK7	-	1
CC11-7-300K3/0	300	3/0	2 X 150BKB	HCPK7	-	1
CC11-7-300K2/0	300	2/0	250BKB	HCPK7	-	1
CC11-7-300K1/0	300	1/0	250BKB	HCPK7	-	1
CC11-7-300K#1	300	#1	200BKB	HCPK7	-	1
CC11-7-300K#2	300	#2	150BKB	HCPK7	-	1
CC11-8-350K350K	350	350	2 X 250BKB	HCPK8	-	1
CC11-8-350K300K	350	300	2 X 250BKB	HCPK8	-	1
CC11-8-350K250K	350	250	2 X 250BKB	HCPK8	-	1
CC11-8-350K4/0	350	4/0	2 X 200BKB	HCPK8	-	1
CC11-8-350K3/0	350	3/0	2 X 200BKB	HCPK8	-	1
CC11-7-350K2/0	350	2/0	2 X 150BKB	HCPK7	-	1
CC11-7-350K1/0	350	1/0	250BKB	HCPK7	-	1
CC11-7-350K#1	350	#1	200BKB	HCPK7	-	1
CC11-7-350K#2	350	#2	200BKB	HCPK7	-	1
CC11-8-500K500K	500	500	3 X 250BKB	HCPK8	-	1
CC11-8-500K350K	500	350	3 X 200BKB	HCPK8	-	1
CC11-8-500K300K	500	300	3 X 200BKB	HCPK8	-	1
CC11-8-500K250K	500	250	2 X 250BKB	HCPK8	-	1
CC11-8-500K4/0	500	4/0	2 X 250BKB	HCPK8	-	1
CC11-8-500K3/0	500	3/0	2 X 250BKB	HCPK8	-	1
CC11-8-500K2/0	500	2/0	2 X 200BKB	HCPK8	-	1
CC11-8-500K1/0	500	1/0	2 X 150BKB	HCPK8	-	1

Exothermic welding system

CR1 cable to ground rod

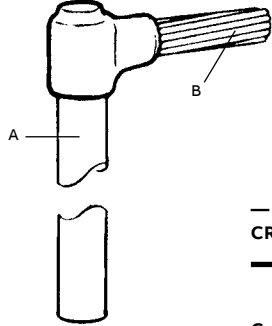

- Stranded conductor
- Solid circular conductor

CR1

Cat. no.	Rod size A	Wire size (AWG or kcmil) B	Welding powder size	Handle clamp type	Sleeve	Std. qty.
CR1-3-500#6	½ in. Nominal diameter actual shank dia. 0.476 in. (non UL rod)	#6	65BKB	HCPK3	1 X Sleeve#6	1
CR1-3-500#6S		#6 solid	65BKB	HCPK3	1 X Sleeve#6S	1
CR1-3-500#4		#4	65BKB	HCPK3	-	1
CR1-3-500#4S		#4 solid	45BKB	HCPK3	-	1
CR1-3-500#2		#2	65BKB	HCPK3	-	1
CR1-3-500#2S		#2 solid	65BKB	HCPK3	-	1
CR1-4-500#1		#1	65BKB	HCPK4	-	1
CR1-4-5001/0		1/0	90BKB	HCPK4	-	1
CR1-4-5001/0S		1/0 solid	90BKB	HCPK4	-	1
CR1-4-5002/0		2/0	90BKB	HCPK4	-	1
CR1-4-5003/0		3/0	90BKB	HCPK4	-	1
CR1-4-5004/0		4/0	90BKB	HCPK4	-	1
CR1-4-500250K		250	90BKB	HCPK4	-	1
CR1-4-500300K		300	90BKB	HCPK4	-	1
CR1-3-500L#6	½ in. True diameter actual shank dia. 0.502 in. (UL rod)	#6	45BKB	HCPK3	1 X Sleeve#6	1
CR1-3-500L#6S		#6 solid	45BKB	HCPK3	1 X Sleeve#6S	1
CR1-3-500L#4		#4	45BKB	HCPK3	-	1
CR1-3-500L#4S		#4 solid	45BKB	HCPK3	-	1
CR1-3-500L#2		#2	65BKB	HCPK3	-	1
CR1-3-500L#2S		#2 solid	65BKB	HCPK3	-	1
CR1-4-500L#1		#1	65BKB	HCPK4	-	1
CR1-4-500L1/0		1/0	90BKB	HCPK4	-	1
CR1-4-500L1/0S		1/0 solid	90BKB	HCPK4	-	1
CR1-4-500L2/0		2/0	90BKB	HCPK4	-	1
CR1-4-500L3/0		3/0	90BKB	HCPK4	-	1
CR1-4-500L4/0		4/0	90BKB	HCPK4	-	1
CR1-4-500L250K		250	90BKB	HCPK4	-	1
CR1-4-500L300K		300	90BKB	HCPK4	-	1

For connections to extensible (threaded) rods – remove top threaded section.

Exothermic welding system

CR1 cable to ground rod

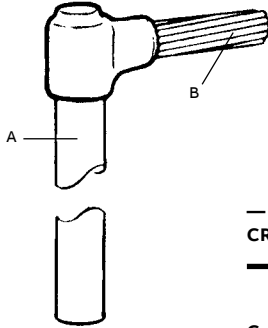

- Stranded conductor
- Solid circular conductor

CR1 (cont'd)

Cat. no.	Rod size A	Wire size (AWG or kcmil) B	Welding powder size	Handle clamp type	Sleeve	Std. qty.
CR1-3-625#6	3/8 in. Nominal diameter actual shank dia. 0.560 in.	#6	65BKB	HCPK4	1 X Sleeve#6	1
CR1-3-625#6S		#6 solid	65BKB	HCPK4	1 X Sleeve#6S	1
CR1-3-625#4		#4	65BKB	HCPK4	-	1
CR1-3-625#4S		#4 solid	65BKB	HCPK4	-	1
CR1-4-625#2		#2	65BKB	HCPK4	-	1
CR1-4-625#2S		#2 solid	65BKB	HCPK4	-	1
CR1-4-625#1		#1	65BKB	HCPK4	-	1
CR1-4-6251/0		1/0	90BKB	HCPK4	-	1
CR1-4-6251/0S	1/0 solid	90BKB	HCPK4	-	1	
CR1-4-6252/0		2/0	90BKB	HCPK4	-	1
CR1-4-6253/0		3/0	90BKB	HCPK4	-	1
CR1-4-6254/0		4/0	90BKB	HCPK4	-	1
CR1-4-625250K		250	90BKB	HCPK4	-	1
CR1-4-625300K		300	115BKB	HCPK4	-	1
CR1-4-625350K		350	115BKB	HCPK4	-	1
CR1-4-625500K		500	150BKB	HCPK4	-	1
CR1-3-750#6	3/4 in. Nominal diameter actual shank dia. 0.678 in.	#6	32BKB	HCPK3	1 X Sleeve#6	1
CR1-3-750#6S		#6 solid	32BKB	HCPK3	1 X Sleeve#6S	1
CR1-3-750#4		#4	45BKB	HCPK3	-	1
CR1-3-750#4S		#4 solid	45BKB	HCPK3	-	1
CR1-4-750#2		#2	90BKB	HCPK4	-	1
CR1-4-750#2S		#2 solid	90BKB	HCPK4	-	1
CR1-4-750#1		#1	90BKB	HCPK4	-	1
CR1-4-7501/0		1/0	90BKB	HCPK4	-	1
CR1-4-7501/0S	1/0 solid	90BKB	HCPK4	-	1	
CR1-4-7502/0		2/0	90BKB	HCPK4	-	1
CR1-4-7503/0		3/0	90BKB	HCPK4	-	1
CR1-4-7504/0		4/0	90BKB	HCPK4	-	1
CR1-4-750250K		250	90BKB	HCPK4	-	1
CR1-4-750300K		300	115BKB	HCPK4	-	1
CR1-4-750350K		350	115BKB	HCPK4	-	1
CR1-4-750500K		500	150BKB	HCPK4	-	1

For connections to extensible (threaded) rods – remove top threaded section.

Exothermic welding system

CR2 cable to ground rod

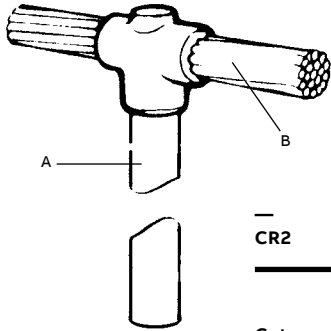

- Stranded conductor
- Solid circular conductor

CR2

Cat. no.	Rod size A	Wire size (AWG or kcmil) B	Welding powder size	Handle clamp type	Sleeve	Std. qty.
CR2-3-500#6	½ in. Nominal diameter actual shank dia. 0.476 in. (non UL rod)	#6	65BKB	HCPK3	Sleeve#6	-
CR2-3-500#6S		#6 solid	65BKB	HCPK3	Sleeve#6S	-
CR2-3-500#4		#4	65BKB	HCPK3	-	-
CR2-3-500#4S		#4 solid	65BKB	HCPK3	-	-
CR2-4-500#2		#2	90BKB	HCPK3	-	-
CR2-4-500#2S		#2 solid	90BKB	HCPK3	-	-
CR2-4-500#1		#1	90BKB	HCPK4	-	-
CR2-4-5001/0		1/0	90BKB	HCPK4	-	-
CR2-4-5001/0S		1/0 solid	90BKB	HCPK4	-	-
CR2-4-5002/0		2/0	90BKB	HCPK4	-	-
CR2-4-5003/0		3/0	115BKB	HCPK4	-	-
CR2-4-5004/0		4/0	115BKB	HCPK4	-	-
CR2-4-500250K		250	150BKB	HCPK4	-	-
CR2-4-500300K		300	200BKB	HCPK4	-	-
CR2-3-500L#6	½ in. True diameter actual shank dia. 0.502 in. (UL rod)	#6	65BKB	HCPK3	Sleeve#6	-
CR2-3-500L#6S		#6 solid	65BKB	HCPK3	Sleeve#6S	-
CR2-3-500L#4		#4	65BKB	HCPK3	-	-
CR2-3-500L#4S		#4 solid	65BKB	HCPK3	-	-
CR2-4-500L#2		#2	90BKB	HCPK3	-	-
CR2-4-500L#2S		#2 solid	90BKB	HCPK3	-	-
CR2-4-500L#1		#1	90BKB	HCPK4	-	-
CR2-4-500L1/0		1/0	90BKB	HCPK4	-	-
CR2-4-500L1/0S		1/0 solid	90BKB	HCPK4	-	-
CR2-4-500L2/0		2/0	90BKB	HCPK4	-	-
CR2-4-500L3/0		3/0	115BKB	HCPK4	-	-
CR2-4-500L4/0		4/0	115BKB	HCPK4	-	-
CR2-4-500L250K		250	150BKB	HCPK4	-	-
CR2-4-500L300K		300	200BKB	HCPK4	-	-

For connections to extensible (threaded) rods – remove top threaded section.

Exothermic welding system

CR2 cable to ground rod

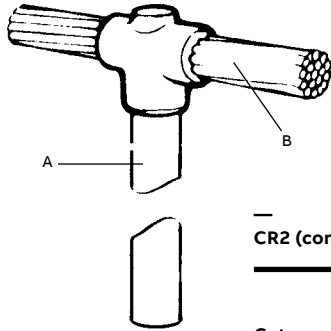

- Stranded conductor
- Solid circular conductor

CR2 (cont'd)

Cat. no.	Rod size A	Wire size (AWG or kcmil) B	Welding powder size	Handle clamp type	Sleeve	Std. qty.
CR2-3-625#6	3/8 in. Nominal diameter actual shank dia. 0.560 in.	#6	32BKB	HCPK3	Sleeve#6	-
CR2-3-625#6S		#6 solid	32BKB	HCPK3	Sleeve#6S	-
CR2-3-625#4		#4	32BKB	HCPK3	-	-
CR2-3-625#4S		#4 solid	32BKB	HCPK3	-	-
CR2-4-625#2		#2	90BKB	HCPK4	-	-
CR2-4-625#2S		#2 solid	90BKB	HCPK4	-	-
CR2-4-625#1		#1	90BKB	HCPK4	-	-
CR2-4-6251/0		1/0	90BKB	HCPK4	-	-
CR2-4-6251/0S	1/0 solid	115BKB	HCPK4	-	-	
CR2-4-6252/0		2/0	115BKB	HCPK4	-	-
CR2-4-6253/0		3/0	115BKB	HCPK4	-	-
CR2-4-6254/0		4/0	115BKB	HCPK4	-	-
CR2-4-625250K		250	150BKB	HCPK4	-	-
CR2-4-625300K		300	200BKB	HCPK4	-	-
CR2-4-625350K		350	200BKB	HCPK4	-	-
CR2-4-625500K		500	200BKB	HCPK4	-	-
CR2-3-750#6	3/8 in. Nominal diameter actual shank dia. 0.678 in.	#6	65BKB	HCPK3	Sleeve#6	1
CR2-3-750#6S		#6 solid	65BKB	HCPK3	Sleeve#6S	1
CR2-3-750#4		#4	65BKB	HCPK3	-	1
CR2-3-750#4S		#4 solid	65BKB	HCPK3	-	1
CR2-4-750#2		#2	90BKB	HCPK4	-	1
CR2-4-750#2S		#2 solid	90BKB	HCPK4	-	1
CR2-4-750#1		#1	90BKB	HCPK4	-	1
CR2-4-7501/0		1/0	115BKB	HCPK4	-	1
CR2-4-7501/0S	1/0 solid	115BKB	HCPK4	-	1	
CR2-4-7502/0		2/0	115BKB	HCPK4	-	1
CR2-4-7503/0		3/0	115BKB	HCPK4	-	1
CR2-4-7504/0		4/0	115BKB	HCPK4	-	1
CR2-4-750250K		250	150BKB	HCPK4	-	1
CR2-4-750300K		300	200BKB	HCPK4	-	1
CR2-4-750350K		350	200BKB	HCPK4	-	1
CR2-4-750500K		500	200BKB	HCPK4	-	1

For connections to extensible (threaded) rods – remove top threaded section.

Exothermic welding system

CR3 cable to ground rod

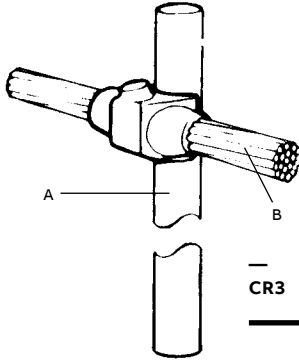

- Stranded conductor
- Solid circular conductor

Cat. no.	Wire size		Welding powder size	Handle clamp type	Sleeve	Std. qty.
	Rod size A	(AWG or kcmil) B				
CR3-9-5001/0	½ in. Nominal diameter actual shank dia. 0.476 in. (non UL rod)	1/0	115BKB	HCPK4 and FRAME1	-	1
CR3-9-5001/0S		1/0 solid	115BKB	HCPK4 and FRAME1	-	1
CR3-9-5002/0		2/0	115BKB	HCPK4 and FRAME1	-	1
CR3-9-5003/0		3/0	150BKB	HCPK4 and FRAME1	-	1
CR3-9-5004/0		4/0	150BKB	HCPK4 and FRAME1	-	1
CR3-9-500250K		250	150BKB	HCPK4 and FRAME1	-	1
CR3-9-500300K		300	200BKB	HCPK4 and FRAME1	-	1
CR3-9-500L1/0	½ in. Nominal diameter actual shank dia. 0.502 in. (UL rod)	1/0	115BKB	HCPK4 and FRAME1	-	1
CR3-9-500L1/0S		1/0 solid	115BKB	HCPK4 and FRAME1	-	1
CR3-9-500L2/0		2/0	115BKB	HCPK4 and FRAME1	-	1
CR3-9-500L3/0		3/0	150BKB	HCPK4 and FRAME1	-	1
CR3-9-500L4/0		4/0	150BKB	HCPK4 and FRAME1	-	1
CR3-9-500L250K		250	150BKB	HCPK4 and FRAME1	-	1
CR3-9-500300K		300	200BKB	HCPK4 and FRAME1	-	1
CR3-9-6251/0	¾ in. Nominal diameter actual shank dia. 0.560 in.	1/0	115BKB	HCPK4 and FRAME1	-	1
CR3-9-6251/0S		1/0 solid	115BKB	HCPK4 and FRAME1	-	1
CR3-9-6252/0		2/0	115BKB	HCPK4 and FRAME1	-	1
CR3-9-6253/0		3/0	150BKB	HCPK4 and FRAME1	-	1
CR3-9-6254/0		4/0	150BKB	HCPK4 and FRAME1	-	1
CR3-9-625250K		250	150BKB	HCPK4 and FRAME1	-	1
CR3-9-625300K		300	200BKB	HCPK4 and FRAME1	-	1
CR3-9-625350K	350	250BKB	HCPK4 and FRAME1	-	1	
CR3-10-625500K		500	2 X 200BKB	HCPK5 and FRAME2	-	1
CR3-9-7501/0	¾ in. Nominal diameter actual shank dia. 0.678 in.	1/0	115BKB	HCPK5 and FRAME2	-	1
CR3-9-7501/0S		1/0 solid	115BKB	HCPK4 and FRAME1	-	1
CR3-9-7502/0		2/0	115BKB	HCPK4 and FRAME1	-	1
CR3-9-7503/0		3/0	115BKB	HCPK4 and FRAME1	-	1
CR3-9-7504/0		4/0	115BKB	HCPK4 and FRAME1	-	1
CR3-9-750250K		250	200BKB	HCPK4 and FRAME1	-	1
CR3-9-750300K		300	200BKB	HCPK4 and FRAME1	-	1
CR3-10-750350K		350	2 X 150BKB	HCPK5 and FRAME2	-	1
CR3-10-750500K		500	2 X 250BKB	HCPK5 and FRAME2	-	1

For connections to extensible (threaded) rods – remove top threaded section.

Exothermic welding system

CRE1 and CRE3 cable to rebar

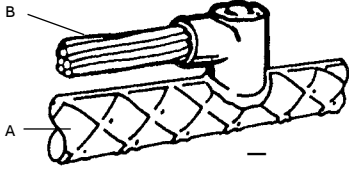

- Stranded conductor
- Solid circular conductor

CRE1

Cat. no.	Rod size A	Wire size (AWG or kcmil) B	Welding powder size	Handle clamp type	Sleeve	Pkg.	Std. qty.
CRE1-4-#43R	3	#4	32BKB	HCPK4	-	-	1
CRE1-4-#2S3R	3	2 solid	45BKB	HCPK4	-	-	1
CRE1-4-#23R	3	#2	45BKB	HCPK4	-	-	1
CRE1-4-#13R	3	#1	65BKB	HCPK4	-	-	1
CRE1-4-1/03R	3	1/0	90BKB	HCPK4	-	-	1
CRE1-4-2/03R	3	2/0	90BKB	HCPK4	-	-	1
CRE1-4-3/03R	3	3/0	115BKB	HCPK4	-	-	1
CRE1-3-#4Z	4 to 7	#4	32BKB	HCPK3B	-	Pack-A	1
CRE1-3-#2SZ	4 to 7	#2 solid	45BKB	HCPK3B	-	Pack-A	1
CRE1-3-#2Z	4 to 7	#2	45BKB	HCPK3B	-	Pack-A	1
CRE1-3-#1Z	4 to 7	#1	65BKB	HCPK3B	-	Pack-A	1
CRE1-3-1/0Z	4 to 7	1/0	90BKB	HCPK3B	-	Pack-A	1
CRE1-3-2/0Z	4 to 7	2/0	90BKB	HCPK3B	-	Pack-A	1
CRE1-3-3/0Z	4 to 7	3/0	115BKB	HCPK3B	-	Pack-A	1
CRE1-3-4/0Z	4 to 7	4/0	115BKB	HCPK3B	-	Pack-A	1
CRE1-3-#4Y	8 to 11	#4	32BKB	HCPK3B	-	Pack-A	1
CRE1-3-#2SY	8 to 11	#2 solid	45BKB	HCPK3B	-	Pack-A	1
CRE1-3-#2Y	8 to 11	#2	45BKB	HCPK3B	-	Pack-A	1
CRE1-3-#1Y	8 to 11	#1	65BKB	HCPK3B	-	Pack-A	1
CRE1-3-1/0Y	8 to 11	1/0	90BKB	HCPK3B	-	Pack-A	1
CRE1-3-2/0Y	8 to 11	2/0	90BKB	HCPK3B	-	Pack-A	1
CRE1-3-3/0Y	8 to 11	3/0	115BKB	HCPK3B	-	Pack-A	1
CRE1-3-4/0Y	8 to 11	4/0	115BKB	HCPK3B	-	Pack-A	1

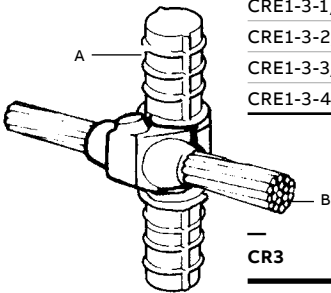

- Stranded conductor
- Solid circular conductor

CR3

Cat. no.	Rod size A	Wire size (AWG or kcmil) B	Welding powder size	Handle clamp type	Sleeve	Pkg.	Std. qty.
CRE3-3-#4Z	4 to 7	#4	90BKB	HCPK3A	-	Pack-A	1
CRE3-3#2SZ	4 to 7	#2 solid	90BKB	HCPK3A	-	Pack-A	1
CRE3-3-#2Z	4 to 7	#2	90BKB	HCPK3A	-	Pack-A	1
CRE3-4-#1Z	4 to 7	#1	115BKB	HCPK3A	-	Pack-A	1
CRE3-4-1/0Z	4 to 7	1/0	115BKB	HCPK3A	-	Pack-A	1
CRE3-4-2/0Z	4 to 7	2/0	115BKB	HCPK3A	-	Pack-A	1
CRE3-4-3/0Z	4 to 7	3/0	150BKB	HCPK3A	-	Pack-A	1
CRE3-4-4/0Z	4 to 7	4/0	150BKB	HCPK3A	-	Pack-A	1
CRE3-3-#4Y	8 to 11	#4	90BKB	HCPK3A	-	Pack-A	1
CRE3-3-#2SY	8 to 11	#2 solid	90BKB	HCPK3A	-	Pack-A	1
CRE3-3-#2Y	8 to 11	#2	90BKB	HCPK3A	-	Pack-A	1
CRE3-4-#1Y	8 to 11	#1	115BKB	HCPK3A	-	Pack-A	1
CRE3-4-1/0Y	8 to 11	1/0	115BKB	HCPK3A	-	Pack-A	1
CRE3-4-2/0Y	8 to 11	2/0	115BKB	HCPK3A	-	Pack-A	1
CRE3-4-3/0Y	8 to 11	3/0	150BKB	HCPK3A	-	Pack-A	1
CRE3-4-4/0Y	8 to 11	4/0	150BKB	HCPK3A	-	Pack-A	1

Exothermic welding system

CRE4 and CRE6 cable to rebar

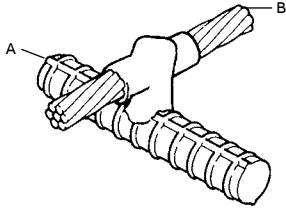

- Stranded conductor
- Solid circular conductor

CRE4

Cat. no.	Rod size A	Wire size (AWG or kcmil) B	Welding powder size	Handle clamp type	Sleeve	Pkg.	Std. qty
CRE4-3-#4Z	4 to 7	#4	65BKB	HCPK3B	-	Pack-A	1
CRE4-3-#2SZ	4 to 7	#2 solid	90BKB	HCPK3B	-	Pack-A	1
CRE4-3-#2Z	4 to 7	#2	90BKB	HCPK3B	-	Pack-A	1
CRE4-3-#1Z	4 to 7	#1	90BKB	HCPK3B	-	Pack-A	1
CRE4-3-1/OZ	4 to 7	1/0	115BKB	HCPK3B	-	Pack-A	1
CRE4-3-2/OZ	4 to 7	2/0	115BKB	HCPK3B	-	Pack-A	1
CRE4-3-3/OZ	4 to 7	3/0	115BKB	HCPK3B	-	Pack-A	1
CRE4-3-4/OZ	4 to 7	4/0	115BKB	HCPK3B	-	Pack-A	1
CRE4-3-#4Y	8 to 11	#4	65BKB	HCPK3B	-	Pack-A	1
CRE4-3-#2SY	8 to 11	#2 solid	90BKB	HCPK3B	-	Pack-A	1
CRE4-3-#2Y	8 to 11	#2	90BKB	HCPK3B	-	Pack-A	1
CRE4-3-#1Y	8 to 11	#1	90BKB	HCPK3B	-	Pack-A	1
CRE4-3-1/OY	8 to 11	1/0	115BKB	HCPK3B	-	Pack-A	1
CRE4-3-2/OY	8 to 11	2/0	115BKB	HCPK3B	-	Pack-A	1
CRE4-3-3/OY	8 to 11	3/0	115BKB	HCPK3B	-	Pack-A	1
CRE4-3-4/OY	8 to 11	4/0	115BKB	HCPK3B	-	Pack-A	1

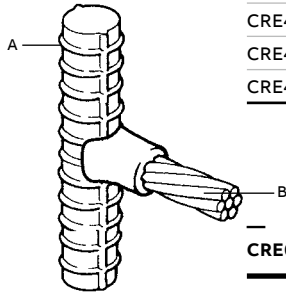

- Stranded conductor
- Solid circular conductor

CRE6

Cat. no.	Rod size A	Wire size (AWG or kcmil) B	Welding powder size	Handle clamp type	Sleeve	Pkg.	Std. qty.
CRE6-3-#4Z	4 to 7	#4	65BKB	HCPK3A	-	Pack-A	1
CRE6-3-#2SZ	4 to 7	#2 solid	65BKB	HCPK3A	-	Pack-A	1
CRE6-3-#2Z	4 to 7	#2	65BKB	HCPK3A	-	Pack-A	1
CRE6-3-#1Z	4 to 7	#1	90BKB	HCPK3A	-	Pack-A	1
CRE6-4-1/OZ	4 to 7	1/0	115BKB	HCPK3A	-	Pack-A	1
CRE6-4-2/OZ	4 to 7	2/0	115BKB	HCPK3A	-	Pack-A	1
CRE6-4-3/OZ	4 to 7	3/0	150BKB	HCPK3A	-	Pack-A	1
CRE6-4-4/OZ	4 to 7	4/0	150BKB	HCPK3A	-	Pack-A	1
CRE6-3-#4Y	8 to 11	#4	65BKB	HCPK3A	-	Pack-A	1
CRE6-3-#2SY	8 to 11	#2 solid	65BKB	HCPK3A	-	Pack-A	1
CRE6-3-#2Y	8 to 11	#2	65BKB	HCPK3A	-	Pack-A	1
CRE6-3-#1Y	8 to 11	#1	90BKB	HCPK3A	-	Pack-A	1
CRE6-4-1/OY	8 to 11	1/0	115BKB	HCPK3A	-	Pack-A	1
CRE6-4-2/OY	8 to 11	2/0	115BKB	HCPK3A	-	Pack-A	1
CRE6-4-3/OY	8 to 11	3/0	150BKB	HCPK3A	-	Pack-A	1
CRE6-4-4/OY	8 to 11	4/0	150BKB	HCPK3A	-	Pack-A	1

Exothermic welding system

CS1 and CS2 cable to steel surface and pipe

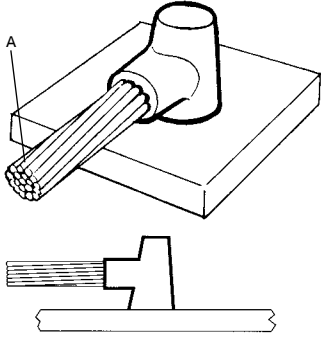

- Stranded conductor
- Solid circular conductor

CS1 – For flat surfaces

Cat. no.	Wire size (AWG or kcmil) A	Welding powder size	Handle clamp type	Sleeve	Std. qty.
CS1-4-1/0	1/0	90BKB	HCPK4	–	1
CS1-4-2/0	2/0	90BKB	HCPK4	–	1
CS1-4-3/0	3/0	115BKB	HCPK4	–	1
CS1-4-4/0	4/0	115BKB	HCPK4	–	1
CS1-4-250K	250	115BKB	HCPK4	–	1
CS1-4-300K	300	150BKB	HCPK4	–	1
CS1-4-350K	350	200BKB	HCPK4	–	1
CS1-4-500K	500	200BKB	HCPK4	–	1
CS1-4-750K	750	2 X 150BKB	HCPK4	–	1
CS1-4-1000K	1,000	2 X 200BKB	HCPK4	–	1

Mold Sealing Compound (MSC) will be required if surface is uneven.

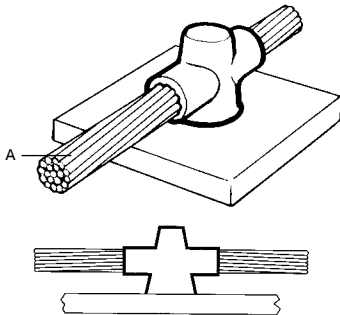

- Stranded conductor
- Solid circular conductor

CS2 – For flat surfaces

Cat. no.	Wire size (AWG or kcmil) A	Welding powder size	Handle clamp type	Sleeve	Std. qty.
CS2-4-1/0	1/0	90BKB	HCPK4	–	1
CS2-4-2/0	2/0	115BKB	HCPK4	–	1
CS2-4-3/0	3/0	115BKB	HCPK4	–	1
CS2-4-4/0	4/0	150BKB	HCPK4	–	1
CS2-4-250K	250	150BKB	HCPK4	–	1
CS2-4-300K	300	200BKB	HCPK4	–	1
CS2-4-350K	350	250BKB	HCPK4	–	1
CS2-5-500K	500	2 X 150BKB	HCPK4	–	1

Mold sealing compound (MSC) will be required if surface is uneven.

Exothermic welding system

CS3 cable to steel surface and pipe

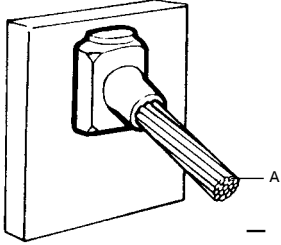

- Stranded conductor
- Solid circular conductor

CS3 – For flat surfaces

Cat. no.	Wire size (AWG or kcmil) A	Welding powder size	Handle clamp type	Sleeve	Std. qty.
CS3-4-#6	#6	45BKB	HCPK4	Sleeve#6	1
CS3-4-#4	#4	45BKB	HCPK4	-	1
CS3-4-#2S	#2 solid	45BKB	HCPK4	-	1
CS3-4-#2	#2	45BKB	HCPK4	-	1
CS3-4-#1	#1	65BKB	HCPK4	-	1
CS3-4-1/0	1/0	90BKB	HCPK4	-	1
CS3-4-2/0	2/0	90BKB	HCPK4	-	1
CS3-4-3/0	3/0	115BKB	HCPK4	-	1
CS3-4-4/0	4/0	115BKB	HCPK4	-	1
CS3-4-250K	250	115BKB	HCPK4	-	1
CS3-4-300K	300	150BKB	HCPK4	-	1
CS3-4-350K	350	200BKB	HCPK4	-	1
CS3-4-500K	500	200BKB	HCPK4	-	1
CS3-5-750K	750	2 X 150BKB	HCPK5	-	1
CS3-5-1000K	1,000	2 X 200BKB	HCPK5	-	1

Mold sealing compound (MSC) will be required if surface is uneven.

Exothermic welding system

CS3 cable to steel surface and pipe

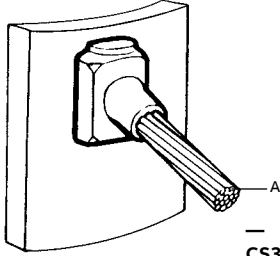

- Stranded conductor
- Solid circular conductor

CS3 – For pipes

Cat. no.	Wire size (AWG or kcmil) A	Pipe size (in.)	Welding powder size	Handle clamp type	Sleeve	Std. qty.
CS3-4-#4C	#4	1½ to 2¾	45BKB	HCPK4	–	1
CS3-4-#4D	#4	2¾ to 6½	45BKB	HCPK4	–	1
CS3-4-#4F	#4	6½ to 10	45BKB	HCPK4	–	1
CS3-4-#4G	#4	10 to 14	45BKB	HCPK4	–	1
CS3-4-#2SC	#2 solid	1½ to 2¾	45BKB	HCPK4	–	1
CS3-4-#2SD	#2 solid	2¾ to 6½	45BKB	HCPK4	–	1
CS3-4-#2SF	#2 solid	6½ to 10	45BKB	HCPK4	–	1
CS3-4-#2SG	#2 solid	10 to 14	45BKB	HCPK4	–	1
CS3-4-#2C	#2	1½ to 2¾	45BKB	HCPK4	–	1
CS3-4-#2D	#2	2¾ to 6½	45BKB	HCPK4	–	1
CS3-4-#2F	#2	6½ to 10	45BKB	HCPK4	–	1
CS3-4-#2G	#2	10 to 14	45BKB	HCPK4	–	1
CS3-4-#1C	#1	1½ to 2¾	65BKB	HCPK4	–	1
CS3-4-#1D	#1	2¾ to 6½	65BKB	HCPK4	–	1
CS3-4-#1F	#1	6½ to 10	65BKB	HCPK4	–	1
CS3-4-#1G	#1	10 to 14	65BKB	HCPK4	–	1
CS3-4-#1/0C	1/0	1½ to 2¾	90BKB	HCPK4	–	1
CS3-4-#1/0D	1/0	2¾ to 6½	90BKB	HCPK4	–	1
CS3-4-#1/0F	1/0	6½ to 10	90BKB	HCPK4	–	1
CS3-4-#1/0G	1/0	10 to 14	90BKB	HCPK4	–	1
CS3-4-#2/0C	2/0	1½ to 2¾	90BKB	HCPK4	–	1
CS3-4-#2/0D	2/0	2¾ to 6½	90BKB	HCPK4	–	1
CS3-4-#2/0F	2/0	6½ to 10	90BKB	HCPK4	–	1
CS3-4-#2/0G	2/0	10 to 14	90BKB	HCPK4	–	1
CS3-4-#3/0C	3/0	1½ to 2¾	115BKB	HCPK4	–	1
CS3-4-#3/0D	3/0	2¾ to 6½	115BKB	HCPK4	–	1
CS3-4-#3/0F	3/0	6½ to 10	115BKB	HCPK4	–	1
CS3-4-#3/0G	3/0	10 to 14	115BKB	HCPK4	–	1
CS3-4-#4/0C	4/0	1½ to 2¾	115BKB	HCPK4	–	1
CS3-4-#4/0D	4/0	2¾ to 6½	115BKB	HCPK4	–	1
CS3-4-#4/0F	4/0	6½ to 10	115BKB	HCPK4	–	1
CS3-4-#4/0G	4/0	10 to 14	115BKB	HCPK4	–	1

Over 14 in. use CS3 for flat surface

Use mold sealing compound (MSC) to ensure effective sealing.

Exothermic welding system

CS4 cable to steel surface and pipe

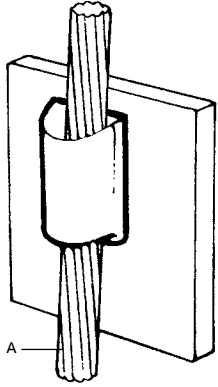

- Stranded conductor
- Solid circular conductor

—
CS4 – For flat surfaces

Cat. no.	Wire size (AWG or kcmil) A	Welding powder size	Handle clamp type	Sleeve	Std. qty.
CS4-4-#6	#6	90BKB	HCPK4	Sleeve#6	1
CS4-4-#4	#4	90BKB	HCPK4	-	1
CS4-4-#2S	#2 solid	115BKB	HCPK4	-	1
CS4-4-#2	#2	115BKB	HCPK4	-	1
CS4-4-#1	#1	115BKB	HCPK4	-	1
CS4-5-1/0	1/0	200BKB	HCPK5	-	1
CS4-5-2/0	2/0	200BKB	HCPK5	-	1
CS4-5-3/0	3/0	250BKB	HCPK5	-	1
CS4-5-4/0	4/0	250BKB	HCPK5	-	1
CS4-5-250K	250	250BKB	HCPK5	-	1

Mold sealing compound (MSC) will be required if surface is uneven.

Exothermic welding system

CS4 cable to steel surface and pipe

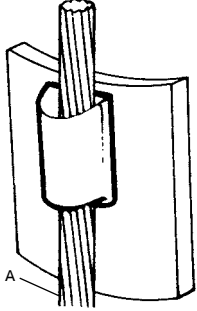

- Stranded conductor
- Solid circular conductor

CS4 – For pipes

Cat. no.	Wire size (AWG or kcmil) A	Pipe size (in.)	Welding powder size	Handle clamp type	Sleeve	std. qty.
CS4-4-#4C	#4	1½ to 2¾	90BKB	HCPK4	-	1
CS4-4-#4D	#4	2¾ to 6½	90BKB	HCPK4	-	1
CS4-4-#4F	#4	6½ to 10	90BKB	HCPK4	-	1
CS4-4-#4G	#4	10 to 14	90BKB	HCPK4	-	1
CS4-4-#2SC	#2 solid	1½ to 2¾	115BKB	HCPK4	-	1
CS4-4-#2SD	#2 solid	2¾ to 6½	115BKB	HCPK4	-	1
CS4-4-#2SF	#2 solid	6½ to 10	115BKB	HCPK4	-	1
CS4-4-#2SG	#2 solid	10 to 14	115BKB	HCPK4	-	1
CS4-4-#2C	#2	1½ to 2¾	115BKB	HCPK4	-	1
CS4-4-#2D	#2	2¾ to 6½	115BKB	HCPK4	-	1
CS4-4-#2F	#2	6½ to 10	115BKB	HCPK4	-	1
CS4-4-#2G	#2	10 to 14	115BKB	HCPK4	-	1
CS4-4-#1C	#1	1½ to 2¾	115BKB	HCPK4	-	1
CS4-4-#1D	#1	2¾ to 6½	115BKB	HCPK4	-	1
CS4-4-#1F	#1	6½ to 10	115BKB	HCPK4	-	1
CS4-4-#1G	#1	10 to 14	115BKB	HCPK4	-	1
CS4-5-1/0C	1/0	1½ to 2¾	200BKB	HCPK5	-	1
CS4-5-1/0D	1/0	2¾ to 6½	200BKB	HCPK5	-	1
CS4-5-1/0F	1/0	6½ to 10	200BKB	HCPK5	-	1
CS4-5-1/0G	1/0	10 to 14	200BKB	HCPK5	-	1
CS4-5-2/0C	2/0	1½ to 2¾	200BKB	HCPK5	-	1
CS4-5-2/0D	2/0	2¾ to 6½	200BKB	HCPK5	-	1
CS4-5-2/0F	2/0	6½ to 10	200BKB	HCPK5	-	1
CS4-5-2/0G	2/0	10 to 14	200BKB	HCPK5	-	1
CS4-5-3/0C	3/0	1½ to 2¾	250BKB	HCPK5	-	1
CS4-5-3/0D	3/0	2¾ to 6½	250BKB	HCPK5	-	1
CS4-5-3/0F	3/0	6½ to 10	250BKB	HCPK5	-	1
CS4-5-3/0G	3/0	10 to 14	250BKB	HCPK5	-	1
CS4-5-4/0C	4/0	1½ to 2¾	250BKB	HCPK5	-	1
CS4-5-4/0D	4/0	2¾ to 6½	250BKB	HCPK5	-	1
CS4-5-4/0F	4/0	6½ to 10	250BKB	HCPK5	-	1
CS4-5-4/0G	4/0	10 to 14	250BKB	HCPK5	-	1

Over 14 in. use CS4 for flat surface
Use mold sealing compound (MSC) to ensure effective sealing.

Exothermic welding system

CS7 cable to steel surface and pipe

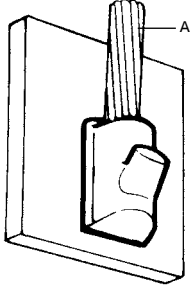

- Stranded conductor
- Solid circular conductor

—
CS7 – For flat surfaces

Cat. no.	Wire size (AWG or kcmil) A	Welding powder size	Handle clamp type	Sleeve	Std. qty.
CS7-4-#4	#4	65BKB	HCPK4	–	1
CS7-4-#2S	#2 solid	65BKB	HCPK4	–	1
CS7-4-#2	#2	65BKB	HCPK4	–	1
CS7-4-#1	#1	90BKB	HCPK4	–	1
CS7-4-1/0	1/0	90BKB	HCPK4	–	1
CS7-4-2/0	2/0	150BKB	HCPK4	–	1
CS7-5-3/0	3/0	200BKB	HCPK4	–	1
CS7-5-4/0	4/0	200BKB	HCPK4	–	1
CS7-5-250K	250	200BKB	HCPK4	–	1
CS7-5-300K	300	250BKB	HCPK4	–	1
CS7-6-350K	350	2 X 150BKB	HCPK5	–	1
CS7-6-500K	500	2 X 200BKB	HCPK5	–	1

Use mold sealing compound (MSC) to ensure effective sealing.

Exothermic welding system

CS7 cable to steel surface and pipe

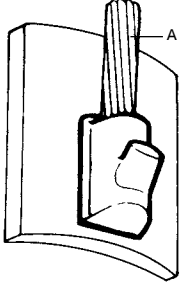

- Stranded conductor
- Solid circular conductor

CS7 – For pipes

Cat. no.	Wire size (AWG) A	Pipe size (in.)	Welding powder size	Handle clamp type	Sleeve	Std. qty.
CS7-4-#4C	#4	1½ to 2¾	65BKB	HCPK4	–	1
CS7-4-#4D	#4	2¾ to 6½	65BKB	HCPK4	–	1
CS7-4-#4F	#4	6½ to 10	65BKB	HCPK4	–	1
CS7-4-#4G	#4	10 to 14	65BKB	HCPK4	–	1
CS7-4-#2SC	#2 solid	1½ to 2¾	65BKB	HCPK4	–	1
CS7-4-#2SD	#2 solid	2¾ to 6½	65BKB	HCPK4	–	1
CS7-4-#2SF	#2 solid	6½ to 10	65BKB	HCPK4	–	1
CS7-4-#2SG	#2 solid	10 to 14	65BKB	HCPK4	–	1
CS7-4-#2C	#2	1½ to 2¾	65BKB	HCPK4	–	1
CS7-4-#2D	#2	2¾ to 6½	65BKB	HCPK4	–	1
CS7-4-#2F	#2	6½ to 10	65BKB	HCPK4	–	1
CS7-4-#2G	#2	10 to 14	65BKB	HCPK4	–	1
CS7-4-#1C	#1	1½ to 2¾	90BKB	HCPK4	–	1
CS7-4-#1D	#1	2¾ to 6½	90BKB	HCPK4	–	1
CS7-4-#1F	#1	6½ to 10	90BKB	HCPK4	–	1
CS7-4-#1G	#1	10 to 14	90BKB	HCPK4	–	1
CS7-4-1/0C	1/0	1½ to 2¾	90BKB	HCPK4	–	1
CS7-4-1/0D	1/0	2¾ to 6½	90BKB	HCPK4	–	1
CS7-4-1/0F	1/0	6½ to 10	90BKB	HCPK4	–	1
CS7-4-1/0G	1/0	10 to 14	90BKB	HCPK4	–	1
CS7-4-2/0C	2/0	1½ to 2¾	150BKB	HCPK4	–	1
CS7-4-2/0D	2/0	2¾ to 6½	150BKB	HCPK4	–	1
CS7-4-2/0F	2/0	6½ to 10	150BKB	HCPK4	–	1
CS7-4-2/0G	2/0	10 to 14	150BKB	HCPK4	–	1
CS7-5-3/0C	3/0	1½ to 2¾	200BKB	HCPK4	–	1
CS7-5-3/0D	3/0	2¾ to 6½	200BKB	HCPK4	–	1
CS7-5-3/0F	3/0	6½ to 10	200BKB	HCPK4	–	1
CS7-5-3/0G	3/0	10 to 14	200BKB	HCPK4	–	1
CS7-5-4/0C	4/0	1½ to 2¾	200BKB	HCPK4	–	1
CS7-5-4/0D	4/0	2¾ to 6½	200BKB	HCPK4	–	1
CS7-5-4/0F	4/0	6½ to 10	200BKB	HCPK4	–	1
CS7-5-4/0G	4/0	10 to 14	200BKB	HCPK4	–	1

Over 14 in. use CS7 for flat surface.

Use mold sealing compound (MSC) to ensure effective sealing.

Exothermic welding system

CS8 and CS9 cable to steel surface and pipe

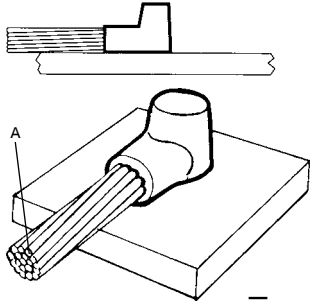

- Stranded conductor
- Solid circular conductor

CS8 – For flat surfaces

Cat. no.	Wire size (AWG) A	Welding powder size	Handle clamp type	Sleeve	Std. qty.
CS8-2-#6	#6	45BKB	HCPK2	Sleeve#6	1
CS8-2-#4	#4	45BKB	HCPK2	-	1
CS8-2-#2S	#2 solid	45BKB	HCPK2	-	1
CS8-2-#2	#2	45BKB	HCPK2	-	1
CS8-2-#1	#1	65BKB	HCPK2	-	1

Use mold sealing compound (MSC) to ensure effective sealing.

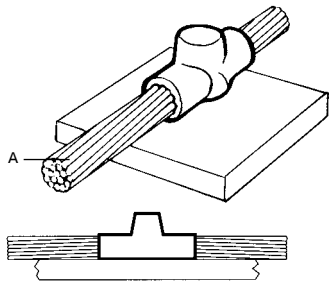

- Stranded conductor
- Solid circular conductor

CS9 – For flat surfaces

Cat. no.	Wire size (AWG) A	Welding powder size	Handle clamp type	Sleeve	Std. qty.
CS9-2-#6	#6	45BKB	HCPK2	Sleeve#6	1
CS9-2-#4	#4	45BKB	HCPK2	-	1
CS9-2-#2S	#2 solid	45BKB	HCPK2	-	1
CS9-2-#2	#2	45BKB	HCPK2	-	1
CS9-2-#1	#1	65BKB	HCPK2	-	1

Use mold sealing compound (MSC) to ensure effective sealing.

Exothermic welding system

CS25 cable to steel surface and pipe

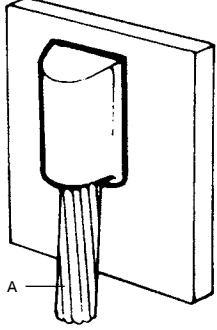

- Stranded conductor
- Solid circular conductor

—
CS25 – For flat surfaces

Cat. no.	Wire size (AWG or kcmil) A	Welding powder size	Handle clamp type	Sleeve	Std. qty.
CS25-4-#4	#4	65BKB	HCPK4	–	1
CS25-4-#2S	#2 solid	65BKB	HCPK4	–	1
CS25-4-#2	#2	65BKB	HCPK4	–	1
CS25-4-#1	#1	90BKB	HCPK4	–	1
CS25-4-1/0	1/0	115BKB	HCPK4	–	1
CS25-4-2/0	2/0	115BKB	HCPK4	–	1
CS25-4-3/0	3/0	150BKB	HCPK4	–	1
CS25-4-4/0	4/0	150BKB	HCPK4	–	1
CS25-4-250K	250	200BKB	HCPK4	–	1
CS25-4-300K	300	200BKB	HCPK4	–	1
CS25-4-350K	350	250BKB	HCPK4	–	1
CS25-4-500K	500	250BKB	HCPK4	–	1

Use mold sealing compound (MSC) to ensure effective sealing.

Exothermic welding system

CS25 cable to steel surface and pipe

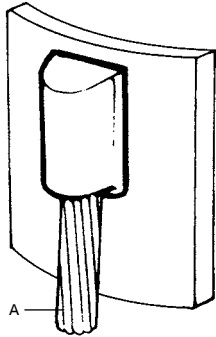

- Stranded conductor
- Solid circular conductor

—
CS25 – For pipes

Cat. no.	Wire size (AWG) A	Pipe size (in.)	Welding powder size	Handle clamp type	Sleeve	Std. qty.
CS25-4-#4C	#4	1½ to 2¾	65BKB	HCPK4	–	1
CS25-4-#4D	#4	2¾ to 6½	65BKB	HCPK4	–	1
CS25-4-#4F	#4	6½ to 10	65BKB	HCPK4	–	1
CS25-4-#4G	#4	10 to 14	65BKB	HCPK4	–	1
CS25-4-#2SC	#2 solid	1½ to 2¾	65BKB	HCPK4	–	1
CS25-4-#2SD	#2 solid	2¾ to 6½	65BKB	HCPK4	–	1
CS25-4-#2SF	#2 solid	6½ to 10	65BKB	HCPK4	–	1
CS25-4-#2SG	#2 solid	10 to 14	65BKB	HCPK4	–	1
CS25-4-#2C	#2	1½ to 2¾	65BKB	HCPK4	–	1
CS25-4-#2D	#2	2¾ to 6½	65BKB	HCPK4	–	1
CS25-4-#2F	#2	6½ to 10	65BKB	HCPK4	–	1
CS25-4-#2G	#2	10 to 14	65BKB	HCPK4	–	1
CS25-4-#1C	#1	1½ to 2¾	90BKB	HCPK4	–	1
CS25-4-#1D	#1	2¾ to 6½	90BKB	HCPK4	–	1
CS25-4-#1F	#1	6½ to 10	90BKB	HCPK4	–	1
CS25-4-#1G	#1	10 to 14	90BKB	HCPK4	–	1
CS25-4-1/0C	1/0	1½ to 2¾	90BKB	HCPK4	–	1
CS25-4-1/0D	1/0	2¾ to 6½	90BKB	HCPK4	–	1
CS25-4-1/0F	1/0	6½ to 10	90BKB	HCPK4	–	1
CS25-4-1/0G	1/0	10 to 14	90BKB	HCPK4	–	1
CS25-4-2/0C	2/0	1½ to 2¾	150BKB	HCPK4	–	1
CS25-4-2/0D	2/0	2¾ to 6½	150BKB	HCPK4	–	1
CS25-4-2/0F	2/0	6½ to 10	150BKB	HCPK4	–	1
CS25-4-2/0G	2/0	10 to 14	150BKB	HCPK4	–	1
CS25-4-3/0C	3/0	1½ to 2¾	200BKB	HCPK4	–	1
CS25-4-3/0D	3/0	2¾ to 6½	200BKB	HCPK4	–	1
CS25-4-3/0F	3/0	6½ to 10	200BKB	HCPK4	–	1
CS25-4-3/0G	3/0	10 to 14	200BKB	HCPK4	–	1
CS25-4-4/0C	4/0	1½ to 2¾	200BKB	HCPK4	–	1
CS25-4-4/0D	4/0	2¾ to 6½	200BKB	HCPK4	–	1
CS25-4-4/0F	4/0	6½ to 10	200BKB	HCPK4	–	1
CS25-4-4/0G	4/0	10 to 14	200BKB	HCPK4	–	1

Over 14 in. use CS25 for flat surface.
Use mold sealing compound (MSC) to ensure effective sealing.

Exothermic welding system

CS27 cable to steel surface and pipe

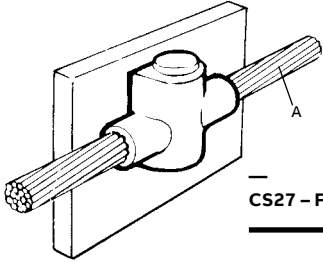

- Stranded conductor
- Solid circular conductor

CS27 – For flat surfaces

Cat. no.	Wire size (AWG or kcmil) A	Welding powder size	Handle clamp type	Sleeve	Std. qty.
CS27-4-#6	#6	45BKB	HCPK4	Sleeve#6	1
CS27-4-#4	#4	45BKB	HCPK4	-	1
CS27-4-#2S	#2 solid	45BKB	HCPK4	-	1
CS27-4-#2	#2	45BKB	HCPK4	-	1
CS27-4-#1	#1	65BKB	HCPK4	-	1
CS27-4-1/0	1/0	115BKB	HCPK4	-	1
CS27-4-2/0	2/0	115BKB	HCPK4	-	1
CS27-4-3/0	3/0	150BKB	HCPK4	-	1
CS27-4-4/0	4/0	150BKB	HCPK4	-	1
CS27-4-250K	250	150BKB	HCPK4	-	1

Exothermic welding system

CS27 cable to steel surface and pipe

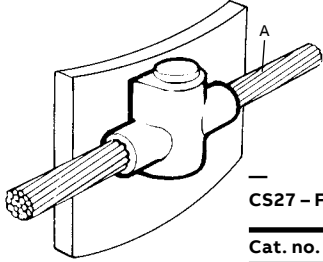

- Stranded conductor
- Solid circular conductor

Cat. no.	Wire size (AWG) A	Pipe size (in.)	Welding powder size	Handle clamp type	Sleeve	Std. qty.
CS27-4-#4C	#4	1½ to 2¾	45BKB	HCPK4	-	1
CS27-4-#4D	#4	2¾ to 6½	45BKB	HCPK4	-	1
CS27-4-#4F	#4	6½ to 10	45BKB	HCPK4	-	1
CS27-4-#4G	#4	10 to 14	45BKB	HCPK4	-	1
CS27-4-#2SC	#2 solid	1½ to 2¾	45BKB	HCPK4	-	1
CS27-4-#2SD	#2 solid	2¾ to 6½	45BKB	HCPK4	-	1
CS27-4-#2SF	#2 solid	6½ to 10	45BKB	HCPK4	-	1
CS27-4-#2SG	#2 solid	10 to 14	45BKB	HCPK4	-	1
CS27-4-#2C	#2	1½ to 2¾	45BKB	HCPK4	-	1
CS27-4-#2D	#2	2¾ to 6½	45BKB	HCPK4	-	1
CS27-4-#2F	#2	6½ to 10	45BKB	HCPK4	-	1
CS27-4-#2G	#2	10 to 14	45BKB	HCPK4	-	1
CS27-4-#1C	#1	1½ to 2¾	65BKB	HCPK4	-	1
CS27-4-#1D	#1	2¾ to 6½	65BKB	HCPK4	-	1
CS27-4-#1F	#1	6½ to 10	65BKB	HCPK4	-	1
CS27-4-#1G	#1	10 to 14	65BKB	HCPK4	-	1
CS27-4-110C	1/0	1½ to 2¾	115BKB	HCPK4	-	1
CS27-4-110D	1/0	2¾ to 6½	115BKB	HCPK4	-	1
CS27-4-110F	1/0	6½ to 10	115BKB	HCPK4	-	1
CS27-4-110G	1/0	10 to 14	115BKB	HCPK4	-	1
CS27-4-210C	2/0	1½ to 2¾	115BKB	HCPK4	-	1
CS27-4-210D	2/0	2¾ to 6½	115BKB	HCPK4	-	1
CS27-4-210F	2/0	6½ to 10	115BKB	HCPK4	-	1
CS27-4-210G	2/0	10 to 14	115BKB	HCPK4	-	1
CS27-4-310C	3/0	1½ to 2¾	150BKB	HCPK4	-	1
CS27-4-310D	3/0	2¾ to 6½	150BKB	HCPK4	-	1
CS27-4-310F	3/0	6½ to 10	150BKB	HCPK4	-	1
CS27-4-310G	3/0	10 to 14	150BKB	HCPK4	-	1
CS27-4-410C	4/0	1½ to 2¾	150BKB	HCPK4	-	1
CS27-4-410D	4/0	2¾ to 6½	150BKB	HCPK4	-	1
CS27-4-410F	4/0	6½ to 10	150BKB	HCPK4	-	1
CS27-4-410G	4/0	10 to 14	150BKB	HCPK4	-	1

Over 14 in. use CS27 for flat surface.
 Use mold sealing compound (MSC) to ensure effective sealing.

Exothermic welding system

CS31 cable to steel surface and pipe

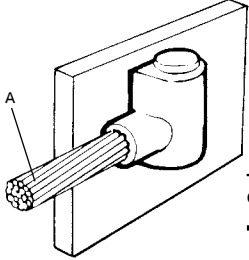

- Stranded conductor
- Solid circular conductor

CS31 – For flat surfaces

Cat. no.	Wire size (AWG or kcmil) A	Welding powder size	Handle clamp type	Sleeve	Std. qty.
CS31-4-#6	#6	45BKB	HCPK4	Sleeve#6	1
CS31-4-#4	#4	45BKB	HCPK4	-	1
CS31-4-#2S	#2 solid	45BKB	HCPK4	-	1
CS31-4-#2	#2	45BKB	HCPK4	-	1
CS31-4-#1	#1	65BKB	HCPK4	-	1
CS31-4-1/0	1/0	90BKB	HCPK4	-	1
CS31-4-2/0	2/0	90BKB	HCPK4	-	1
CS31-4-3/0	3/0	115BKB	HCPK4	-	1
CS31-4-4/0	4/0	115BKB	HCPK4	-	1
CS31-4-250K	250	115BKB	HCPK4	-	1

Add "R" or "L" to denote wire exiting left or right. (Example: CS31-6-#6R for #6 wire exiting on the right.)
Use mold sealing compound (MSC) to ensure effective sealing.

Exothermic welding system

CS31 cable to steel surface and pipe

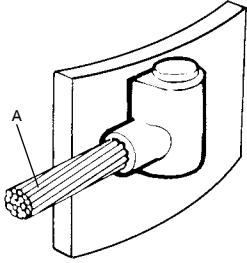

- Stranded conductor
- Solid circular conductor

CS31 – For pipes

Cat. no.	Wire size (AWG) A	Pipe size (in.)	Welding powder size	Handle clamp type	Sleeve	Std. qty.
CS31-4-#4C	#4	1½ to 2¾	45BKB	HCPK4	-	1
CS31-4-#4D	#4	2¾ to 6½	45BKB	HCPK4	-	1
CS31-4-#4F	#4	6½ to 10	45BKB	HCPK4	-	1
CS31-4-#4G	#4	10 to 14	45BKB	HCPK4	-	1
CS31-4-#2SC	#2 solid	1½ to 2¾	45BKB	HCPK4	-	1
CS31-4-#2SD	#2 solid	2¾ to 6½	45BKB	HCPK4	-	1
CS31-4-#2SF	#2 solid	6½ to 10	45BKB	HCPK4	-	1
CS31-4-#2SG	#2 solid	10 to 14	45BKB	HCPK4	-	1
CS31-4-#2C	#2	1½ to 2¾	45BKB	HCPK4	-	1
CS31-4-#2D	#2	2¾ to 6½	45BKB	HCPK4	-	1
CS31-4-#2F	#2	6½ to 10	45BKB	HCPK4	-	1
CS31-4-#2G	#2	10 to 14	45BKB	HCPK4	-	1
CS31-4-#1C	#1	1½ to 2¾	65BKB	HCPK4	-	1
CS31-4-#1D	#1	2¾ to 6½	65BKB	HCPK4	-	1
CS31-4-#1F	#1	6½ to 10	65BKB	HCPK4	-	1
CS31-4-#1G	#1	10 to 14	65BKB	HCPK4	-	1
CS31-4-1/0C	1/0	1½ to 2¾	90BKB	HCPK4	-	1
CS31-4-1/0D	1/0	2¾ to 6½	90BKB	HCPK4	-	1
CS31-4-1/0F	1/0	6½ to 10	90BKB	HCPK4	-	1
CS31-4-1/0G	1/0	10 to 14	90BKB	HCPK4	-	1
CS31-4-2/0C	2/0	1½ to 2¾	90BKB	HCPK4	-	1
CS31-4-2/0D	2/0	2¾ to 6½	90BKB	HCPK4	-	1
CS31-4-2/0F	2/0	6½ to 10	90BKB	HCPK4	-	1
CS31-4-2/0G	2/0	10 to 14	90BKB	HCPK4	-	1
CS31-4-3/0C	3/0	1½ to 2¾	115BKB	HCPK4	-	1
CS31-4-3/0D	3/0	2¾ to 6½	115BKB	HCPK4	-	1
CS31-4-3/0F	3/0	6½ to 10	115BKB	HCPK4	-	1
CS31-4-3/0G	3/0	10 to 14	115BKB	HCPK4	-	1
CS31-4-4/0C	4/0	1½ to 2¾	115BKB	HCPK4	-	1
CS31-4-4/0D	4/0	2¾ to 6½	115BKB	HCPK4	-	1
CS31-4-4/0F	4/0	6½ to 10	115BKB	HCPK4	-	1
CS31-4-4/0G	4/0	10 to 14	115BKB	HCPK4	-	1

Over 14 in. use CS31 for flat surface.

Add "R" or "L" to denote wire exiting left or right. (Example: CS31-6-#6R for #6 wire exiting on the right.)

Use mold sealing compound (MSC) to ensure effective sealing.

Exothermic welding system

CS32 cable to steel surface and pipe

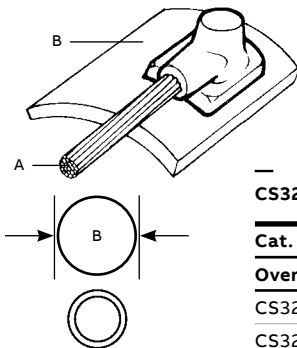

- Stranded conductor

CS32 – For pipes

Cat. no.	Wire size (AWG) A	Pipe size (in.)	Welding powder size	Handle clamp type	Sleeve	Std. qty.
Over 14 in. use CS8 for flat surface						
CS32-2-#4C	#4	1½ to 2¾	45BKB	HCPK2	–	1
CS32-2-#4D	#4	2¾ to 6½	45BKB	HCPK2	–	1
CS32-2-#4F	#4	6½ to 10	45BKB	HCPK2	–	1
CS32-2-#4G	#4	10 to 14	45BKB	HCPK2	–	1
CS32-2-#2SC	#2 solid	1½ to 2¾	45BKB	HCPK2	–	1
CS32-2-#2SD	#2 solid	2¾ to 6½	45BKB	HCPK2	–	1
CS32-2-#2SF	#2 solid	6½ to 10	45BKB	HCPK2	–	1
CS32-2-#2SG	#2 solid	10 to 14	45BKB	HCPK2	–	1
CS32-2-#2C	#2	1½ to 2¾	45BKB	HCPK2	–	1
CS32-2-#2D	#2	2¾ to 6½	45BKB	HCPK2	–	1
CS32-2-#2F	#2	6½ to 10	45BKB	HCPK2	–	1
CS32-2-#2G	#2	10 to 14	45BKB	HCPK2	–	1
CS32-2-#1D	#1	2¾ to 6½	65BKB	HCPK2	–	1
CS32-2-#1F	#1	6½ to 10	65BKB	HCPK2	–	1
CS32-2-#1G	#1	10 to 14	65BKB	HCPK2	–	1
Over 14 in. use CS1 for flat surface						
CS32-4-#1/OD	1/0	2¾ to 6½	90BKB	HCPK4	–	1
CS32-4-#1/OF	1/0	6½ to 10	90BKB	HCPK4	–	1
CS32-4-#1/OG	1/0	10 to 14	90BKB	HCPK4	–	1
CS32-4-#2/OD	2/0	2¾ to 6½	90BKB	HCPK4	–	1
CS32-4-#2/OF	2/0	6½ to 10	90BKB	HCPK4	–	1
CS32-4-#2/OG	2/0	10 to 14	90BKB	HCPK4	–	1
CS32-4-#3/OD	3/0	2¾ to 6½	90BKB	HCPK4	–	1
CS32-4-#3/OF	3/0	6½ to 10	90BKB	HCPK4	–	1
CS32-4-#3/OG	3/0	10 to 14	90BKB	HCPK4	–	1
CS32-4-#4/OD	4/0	2¾ to 6½	90BKB	HCPK4	–	1
CS32-4-#4/OF	4/0	6½ to 10	90BKB	HCPK4	–	1
CS32-4-#4/OG	4/0	10 to 14	90BKB	HCPK4	–	1

Add "R" or "L" to denote wire exiting left or right. (Example: CS31-6-#6R for #6 wire exiting on the right.)
Use mold sealing compound (MSC) to ensure effective sealing.

Exothermic welding system

CS34 cable to steel surface and pipe

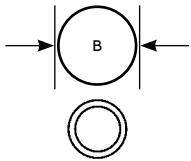
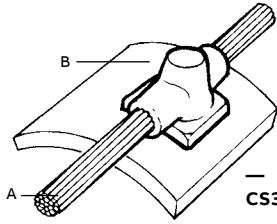

- Stranded conductor

CS34 – For pipes

Cat. no.	Wire size (AWG) A	Pipe size (in.)	Welding powder size	Handle clamp type	Sleeve	Std. qty.
Over 14 in. use CS8 for flat surface						
CS34-2-#4C	#4	1½ to 2¾	45BKB	HCPK2	–	1
CS34-2-#4D	#4	2¾ to 6½	45BKB	HCPK2	–	1
CS34-2-#4F	#4	6½ to 10	45BKB	HCPK2	–	1
CS34-2-#4G	#4	10 to 14	45BKB	HCPK2	–	1
CS34-2-#2SC	#2 solid	1½ to 2¾	45BKB	HCPK2	–	1
CS34-2-#2SD	#2 solid	2¾ to 6½	45BKB	HCPK2	–	1
CS34-2-#2SF	#2 solid	6½ to 10	45BKB	HCPK2	–	1
CS34-2-#2SG	#2 solid	10 to 14	45BKB	HCPK2	–	1
CS34-2-#2C	#2	1½ to 2¾	45BKB	HCPK2	–	1
CS34-2-#2D	#2	2¾ to 6½	45BKB	HCPK2	–	1
CS34-2-#2F	#2	6½ to 10	45BKB	HCPK2	–	1
CS34-2-#2G	#2	10 to 14	45BKB	HCPK2	–	1
CS34-2-#1D	#1	2¾ to 6½	65BKB	HCPK2	–	1
CS34-2-#1F	#1	6½ to 10	65BKB	HCPK2	–	1
CS34-2-#1G	#1	10 to 14	65BKB	HCPK2	–	1
Over 14 in. use CS1 for flat surface						
CS34-4-#1/OD	1/0	2¾ to 6½	90BKB	HCPK4	–	1
CS34-4-#1/OF	1/0	6½ to 10	90BKB	HCPK4	–	1
CS34-4-#1/OG	1/0	10 to 14	90BKB	HCPK4	–	1
CS34-4-#2/OD	2/0	2¾ to 6½	115BKB	HCPK4	–	1
CS34-4-#2/OF	2/0	6½ to 10	115BKB	HCPK4	–	1
CS34-4-#2/OG	2/0	10 to 14	115BKB	HCPK4	–	1
CS34-4-#3/OD	3/0	2¾ to 6½	115BKB	HCPK4	–	1
CS34-4-#3/OF	3/0	6½ to 10	115BKB	HCPK4	–	1
CS34-4-#3/OG	3/0	10 to 14	115BKB	HCPK4	–	1
CS34-4-#4/OD	4/0	2¾ to 6½	150BKB	HCPK4	–	1
CS34-4-#4/OF	4/0	6½ to 10	150BKB	HCPK4	–	1
CS34-4-#4/OG	4/0	10 to 14	150BKB	HCPK4	–	1

Use mold sealing compound (MSC) to ensure effective sealing.

Exothermic welding system

CB1 cable to bare

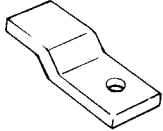
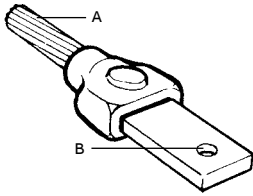

- Stranded conductor
- Solid circular conductor
- Rectangular tape or bar

CB1 – For pipes

Cat. no.	Wire size (AWG or kcmil) A	Bar size (in.) B	Welding powder size	Handle clamp type	Sleeve	Std. qty.
CB1-4-#4181	#4	1/8 X 1	45BKB	HCPK4	-	1
CB1-4-#2181	#2 solid	1/8 X 1	45BKB	HCPK4	-	1
CB1-4-#2181	#2	1/8 X 1	45BKB	HCPK4	-	1
CB1-4-#1181	#1	1/8 X 1	45BKB	HCPK4	-	1
CB1-4-1/0181	1/0	1/8 X 1	45BKB	HCPK4	-	1
CB1-4-1/03161	1/0	3/16 X 1	65BKB	HCPK4	-	1
CB1-4-1/0141	1/0	1/4 X 1	65BKB	HCPK4	-	1
CB1-4-2/0181	2/0	1/8 X 1	65BKB	HCPK4	-	1
CB1-4-2/03161	2/0	3/16 X 1	65BKB	HCPK4	-	1
CB1-4-2/0141	2/0	1/4 X 1	65BKB	HCPK4	-	1
CB1-4-3/018	3/0	1/8 X 1	65BKB	HCPK4	-	1
CB1-4-3/0161	2/0	3/16 X 1	90BKB	HCPK4	-	1
CB1-4-3/0141	2/0	1/4 X 1	90BKB	HCPK4	-	1
CB1-4-4/03161	4/0	3/16 X 1	90BKB	HCPK4	-	1
CB1-4-4/0141	4/0	1/4 X 1	90BKB	HCPK4	-	1
CB1-4-4/014112	4/0	1/4 X 1 1/2	90BKB	HCPK4	-	1
CB1-4-4/0142	4/0	1/4 X 2	90BKB	HCPK4	-	1
CB1-4-4/0143	4/0	1/4 X 3	90BKB	HCPK4	-	1
CB1-4-250K3161	250	3/16 X 1	90BKB	HCPK4	-	1
CB1-4-250K141	250	1/4 X 1	90BKB	HCPK4	-	1
CB1-4-250K14112	250	1/4 X 1 1/2	90BKB	HCPK4	-	1
CB1-4-250K142	250	1/4 X 2	90BKB	HCPK4	-	1
CB1-4-250K143	250	1/4 X 3	90BKB	HCPK4	-	1
CB1-4-300K141	300	1/4 X 1	90BKB	HCPK4	-	1
CB1-4-300K14112	300	1/4 X 1-1/2	90BKB	HCPK4	-	1
CB1-4-300K142	300	1/4 X 2	90BKB	HCPK4	-	1
CB1-4-300K143	300	1/4 X 3	90BKB	HCPK4	-	1
CB1-4-350K141	350	1/4 X 1	115BKB	HCPK4	-	1
CB1-4-350K14112	350	1/4 X 1 1/2	115BKB	HCPK4	-	1
CB1-4-350K142	350	1/4 X 2	115BKB	HCPK4	-	1
CB1-4-350K143	350	1/4 X 3	115BKB	HCPK4	-	1
CB1-4-500K14112	500	1/4 X 1 1/2	200BKB	HCPK4	-	1
CB1-4-500K142	500	1/4 X 2	200BKB	HCPK4	-	1
CB1-4-500K143	500	1/4 X 3	200BKB	HCPK4	-	1
CB1-4-500K38112	500	3/8 X 1 1/2	200BKB	HCPK4	-	1
CB1-5-750K142	750	1/4 X 2	2 X 150BKB	HCPK5	-	1
CB1-5-750K143	750	1/4 X 3	2 X 150BKB	HCPK5	-	1
CB1-5-750k38112	750	3/8 X 1 1/2	2 X 150BKB	HCPK5	-	1
CB1-5-750k382	750	3/8 X 2	2 X 150BKB	HCPK5	-	1
CB1-5-750K383	750	3/8 X 3	2 X 150BKB	HCPK5	-	1
CB1-5-1000K143	1,000	1/4 X 3	2 X 150BKB	HCPK5	-	1
CB1-5-1000K382	1,000	3/8 X 2	2 X 150BKB	HCPK5	-	1
CB1-5-1000K383	1,000	3/8 X 3	2 X 150BKB	HCPK5	-	1
CB1-5-1000K122	1,000	1/2 X 2	2 X 150BKB	HCPK5	-	1
CB1-5-1000K123	1,000	1/2 X 3	2 X 150BKB	HCPK5	-	1

Exothermic welding system

CB4 cable to bar

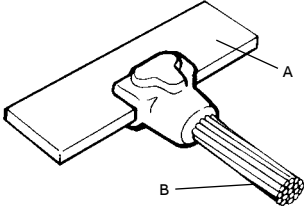

- Stranded conductor
- Solid circular conductor
- Rectangular tape or bar

—
CB4 – For flat surfaces

Cat. no.	Bar size (in.) A	Wire size (AWG or kcmil) B	Welding powder size	Handle clamp type	Sleeve	Std. qty.
CB4-4-#2S14112	¼ X 1½ and wider	#2 solid	45BKB	HCPK4	–	1
CB4-4-214112	¼ X 1½ and wider	#2	45BKB	HCPK4	–	1
CB4-4-1/014112	¼ X 1½ and wider	1/0	90BKB	HCPK4	–	1
CB4-4-2/014112	¼ X 1½ and wider	2/0	90BKB	HCPK4	–	1
CB4-4-3/014112	¼ X 1½ and wider	3/0	90BKB	HCPK4	–	1
CB4-4-4/014112	¼ X 1½ and wider	4/0	90BKB	HCPK4	–	1
CB4-4-250K14112	¼ X 1½ and wider	250	115BKB	HCPK4	–	1
CB4-4-300K14112	¼ X 1½ and wider	300	115BKB	HCPK4	–	1
CB4-4-350K14112	¼ X 1½ and wider	350	150BKB	HCPK4	–	1
CB4-4-500K1411	¼ X 1½ and wider	500	200BKB	HCPK4	–	1
CB4-4-#2S38112	¾ X 1½ and wider	#2 solid	65BKB	HCPK4	–	1
CB4-4-#238112	¾ X 1½ and wider	#2	65BKB	HCPK4	–	1
CB4-4-1/038112	¾ X 1½ and wider	1/0	90BKB	HCPK4	–	1
CB4-4-2/038112	¾ X 1½ and wider	2/0	90BKB	HCPK4	–	1
CB4-4-4/038112	¾ X 1½ and wider	4/0	115BKB	HCPK4	–	1
CB4-4-250K38112	¾ X 1½ and wider	250	150BKB	HCPK4	–	1
CB4-4-300K38112	¾ X 1½ and wider	300	150BKB	HCPK4	–	1
CB4-4-350K38112	¾ X 1½ and wider	350	200BKB	HCPK4	–	1
CB4-4-500K38112	¾ X 1½ and wider	500	250BKB	HCPK4	–	1
CB4-5-750K38112	¾ X 1½ and wider	750	2 X 150BKB	HCPK5	–	1
CB4-5-1000K38112	¾ X 1½ and wider	1,000	2 X 200BKB	HCPK5	–	1
CB4-4-#2S12112	½ X 1½ and wider	#2 solid	90BKB	HCPK4	–	1
CB4-4-#212112	½ X 1½ and wider	#2	90BKB	HCPK4	–	1
CB4-4-1/012112	½ X 1½ and wider	1/0	115BKB	HCPK4	–	1
CB4-4-2/012112	½ X 1½ and wider	2/0	115BKB	HCPK4	–	1
CB4-4-3/012112	½ X 1½ and wider	3/0	150BKB	HCPK4	–	1
CB4-4-4/012112	½ X 1½ and wider	4/0	150BKB	HCPK4	–	1
CB4-4-250K12112	½ X 1½ and wider	250	200BKB	HCPK4	–	1
CB4-4-300K12112	½ X 1½ and wider	300	200BKB	HCPK4	–	1
CB4-4-350K12112	½ X 1½ and wider	350	250BKB	HCPK4	–	1
CB4-5-500K12112	½ X 1½ and wider	500	2 X 150BKB	HCPK5	–	1
CB4-5-750K12112	½ X 1½ and wider	750	2 X 200BKB	HCPK5	–	1
CB4-5-1000K12112	½ X 1½ and wider	1,000	2 X 250BKB	HCPK5	–	1

Exothermic welding system

CB29 cable to bar

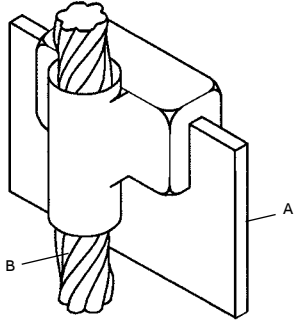

CB29 – For flat surfaces

Cat. no.	Bar size (in.) A	Wire size (AWG or kcmil) B	Welding powder size	Handle clamp type	Sleeve	Std. qty.
CB29-9-#2S142	¼ X 2 and wider	#2 solid	250BKB	HCPK4	–	1
CB29-9-#2142	¼ X 2 and wider	#2	250BKB	HCPK4	–	1
CB29-10-#1142	¼ X 2 and wider	#1	2 X 150BKB	HCPK5	–	1
CB29-10-1/0142	¼ X 2 and wider	1/0	2 X 200BKB	HCPK5	–	1
CB29-10-2/0142	¼ X 2 and wider	2/0	2 X 200BKB	HCPK5	–	1
CB29-10-4/0142	¼ X 2 and wider	4/0	2 X 250BKB	HCPK5	–	1
CB29-10-250K142	¼ X 2 and wider	250	2 X 250BKB	HCPK5	–	1
CB29-10-500K142	¼ X 2 and wider	500	2 X 250BKB	HCPK5	–	1
CB29-10-750K142	¼ X 2 and wider	750	3 X 200BKB	HCPK5	–	1
CB29-9-#2S382	⅜ X 2 and wider	#2 solid	250BKB	HCPK4	–	1
CB29-9-#2382	⅜ X 2 and wider	#2 solid	250BKB	HCPK4	–	1
CB29-10-#1382	⅜ X 2 and wider	#1	2 X 150BKB	HCPK5	–	1
CB29-10-1/0382	⅜ X 2 and wider	1/0	2 X 200BKB	HCPK5	–	1
CB29-102/0382	⅜ X 2 and wider	2/0	2 X 200BKB	HCPK5	–	1
CB29-104/0382	⅜ X 2 and wider	4/0	2 X 250BKB	HCPK5	–	1
CB29-10-250K382	⅜ X 2 and wider	250	2 X 250BKB	HCPK5	–	1
CB29-10-500K382	⅜ X 2 and wider	500	2 X 250BKB	HCPK5	–	1
CB29-10-750K382	⅜ X 2 and wider	750	3 X 200BKB	HCPK5	–	1
CB29-10-#2S122	½ X 2 and wider	#2 solid	2 X 150BKB	HCPK5	–	1
CB29-10-#2122	½ X 2 and wider	#2	2 X 150BKB	HCPK5	–	1
CB29-10-#1122	½ X 2 and wider	#1	2 X 200BKB	HCPK5	–	1
CB29-10-1/0122	½ X 2 and wider	1/0	2 X 250BKB	HCPK5	–	1
CB29-10-2/0122	½ X 2 and wider	2/0	2 X 250BKB	HCPK5	–	1
CB29-10-4/0122	½ X 2 and wider	4/0	3 X 200BKB	HCPK5	–	1
CB29-10-250K122	½ X 2 and wider	250	3 X 200BKB	HCPK5	–	1
CB29-10-500K122	½ X 2 and wider	500	3 X 200BKB	HCPK5	–	1
CB29-10-750K	½ X 2 and wider	750	3 X 250BKB	HCPK5	–	1

Use mold sealing compound (MSC) to ensure effective sealing.

Exothermic welding system

BB1 and BB2 bar to bar

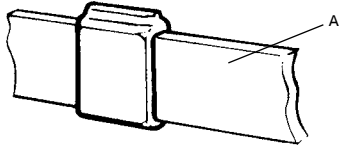

—
BB1 – For flat surfaces

Cat. no.	Bar size (in.) A	Welding powder size	Handle clamp type	Sleeve	Std. qty.
BB1-4-181	1/8 X 1	45BKB	HCPK4	–	1
BB1-4-18112	1/8 X 1 1/2	65BKB	HCPK4	–	1
BB1-4-182	1/8 X 2	90BKB	HCPK4	–	1
BB1-4-183	1/8 X 3	200BKB	HCPK4	–	1
BB1-4-184	1/8 X 4	250BKB	HCPK4	–	1
BB1-4-3161	3/16 X 1	65BKB	HCPK4	–	1
BB1-4-3162	3/16 X 2	115BKB	HCPK4	–	1
BB1-4-141	1/4 X 1	90BKB	HCPK4	–	1
BB1-4-14114	1/4 X 1 1/4	115BKB	HCPK4	–	1
BB1-4-14112	1/4 X 1 1/2	150BKB	HCPK4	–	1
BB1-4-142	1/4 X 2	200BKB	HCPK4	–	1
BB1-4-14212	1/4 X 2 1/2	250BKB	HCPK4	–	1
BB1-5-143	1/4 X 3	2 X 200BKB	HCPK5	–	1
BB1-5-144	1/4 X 4	2 X 250BKB	HCPK5	–	1
BB1-4-381	3/8 X 1	150BKB	HCPK5	–	1
BB1-4-38112	3/8 X 1 1/2	250BKB	HCPK4	–	1
BB1-5-382	3/8 X 2	2 X 150BKB	HCPK5	–	1
BB1-5-383	3/8 X 3	2 X 250BKB	HCPK5	–	1
BB1-5-384	3/8 X 4	3 X 200BKB	HCPK5	–	1
BB1-4-121	1/2 X 1	200BKB	HCPK4	–	1
BB1-5-122	1/2 X 2	2 X 200BKB	HCPK5	–	1

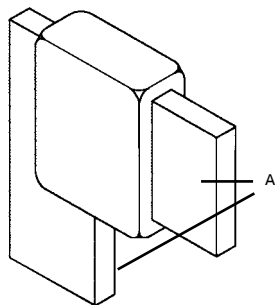

—
BB2 – For flat surfaces

Cat. no.	Bar size (in.) A	Welding powder size	Handle clamp type	Sleeve	Std. qty.
BB2-4-181	1/8 X 1	45BKB	HCPK4	–	1
BB2-4-18112	1/8 X 1 1/2	65BKB	HCPK4	–	1
BB2-4-182	1/8 X 2	90BKB	HCPK4	–	1
BB2-4-183	1/8 X 3	200BKB	HCPK4	–	1
BB2-4-184	1/8 X 4	250BKB	HCPK4	–	1
BB2-4-3161	3/16 X 1	65BKB	HCPK4	–	1
BB2-4-3162	3/16 X 2	115BKB	HCPK4	–	1
BB2-4-141	1/4 X 1	90BKB	HCPK4	–	1
BB2-4-14114	1/4 X 1 1/4	115BKB	HCPK4	–	1
BB2-4-14112	1/4 X 1 1/2	150BKB	HCPK4	–	1
BB2-4-142	1/4 X 2	200BKB	HCPK4	–	1
BB2-4-14212	1/4 X 2 1/2	250BKB	HCPK4	–	1
BB2-5-143	1/4 X 3	2 X 200BKB	HCPK5	–	1
BB2-5-144	1/4 X 4	2 X 250BKB	HCPK5	–	1
BB2-4-381	3/8 X 1	150BKB	HCPK5	–	1
BB2-4-38112	3/8 X 1 1/2	250BKB	HCPK4	–	1
BB2-5-382	3/8 X 2	2 X 150BKB	HCPK5	–	1
BB2-5-383	3/8 X 3	2 X 250BKB	HCPK5	–	1
BB2-5-384	3/8 X 4	3 X 200BKB	HCPK5	–	1
BB2-4-121	1/2 X 1	200BKB	HCPK4	–	1
BB2-5-122	1/2 X 2	2 X 200BKB	HCPK5	–	1

Exothermic welding system

BB3 and BB7 bar to bar

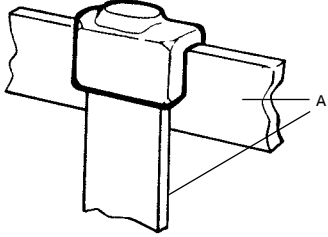

BB3 – For flat surfaces

Cat. no.	Bar size (in.) A	Welding powder size	Handle clamp type	Sleeve	Std. qty.
BB3-4-181	1/8 X 1	45BKB	HCPK4	-	1
BB3-4-18112	1/8 X 1 1/2	65BKB	HCPK4	-	1
BB3-4-182	1/8 X 2	90BKB	HCPK4	-	1
BB3-4-183	1/8 X 3	200BKB	HCPK4	-	1
BB3-4-184	1/8 X 4	250BKB	HCPK4	-	1
BB3-4-3161	3/16 X 1	65BKB	HCPK4	-	1
BB3-4-3162	3/16 X 2	115BKB	HCPK4	-	1
BB3-4-141	1/4 X 1	90BKB	HCPK4	-	1
BB3-4-14114	1/4 X 1 1/4	115BKB	HCPK4	-	1
BB3-4-14112	1/4 X 1 1/2	150BKB	HCPK4	-	1
BB3-4-142	1/4 X 2	200BKB	HCPK4	-	1
BB3-4-14212	1/4 X 2 1/2	250BKB	HCPK4	-	1
BB3-5-143	1/4 X 3	2 X 200BKB	HCPK5	-	1
BB3-5-144	1/4 X 4	2 X 250BKB	HCPK5	-	1
BB3-4-381	3/8 X 1	150BKB	HCPK5	-	1
BB3-4-38112	3/8 X 1 1/2	250BKB	HCPK4	-	1
BB3-5-382	3/8 X 2	2 X 150BKB	HCPK5	-	1
BB3-5-383	3/8 X 3	2 X 250BKB	HCPK5	-	1
BB3-5-384	3/8 X 4	3 X 200BKB	HCPK5	-	1
BB3-4-121	1/2 X 1	200BKB	HCPK4	-	1
BB3-5-122	1/2 X 2	2 X 200BKB	HCPK5	-	1

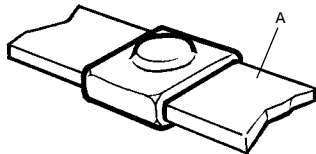

BB7 – For flat surfaces

Cat. no.	Bar size (in.) A	Welding powder size	Handle clamp type	Sleeve	Std. qty.
BB7-4-181	1/8 X 1	45BKB	HCPK4	-	1
BB7-4-18112	1/8 X 1 1/2	65BKB	HCPK4	-	1
BB7-4-182	1/8 X 2	90BKB	HCPK4	-	1
BB7-4-183	1/8 X 3	200BKB	HCPK4	-	1
BB7-4-184	1/8 X 4	250BKB	HCPK4	-	1
BB7-4-3161	3/16 X 1	65BKB	HCPK4	-	1
BB7-4-3162	3/16 X 2	115BKB	HCPK4	-	1
BB7-4-141	1/4 X 1	90BKB	HCPK4	-	1
BB7-4-14114	1/4 X 1 1/4	115BKB	HCPK4	-	1
BB7-4-14112	1/4 X 1 1/2	150BKB	HCPK4	-	1
BB7-4-142	1/4 X 2	200BKB	HCPK4	-	1
BB7-4-14212	1/4 X 2 1/2	250BKB	HCPK4	-	1
BB7-5-143	1/4 X 3	2 X 200BKB	HCPK5	-	1
BB7-5-144	1/4 X 4	2 X 250BKB	HCPK5	-	1
BB7-4-381	3/8 X 1	150BKB	HCPK5	-	1
BB7-4-38112	3/8 X 1 1/2	250BKB	HCPK5	-	1
BB7-5-382	3/8 X 2	2 X 150BKB	HCPK5	-	1
BB7-5-383	3/8 X 3	2 X 250BKB	HCPK5	-	1
BB7-5-384	3/8 X 4	3 X 200BKB	HCPK5	-	1
BB7-4-121	1/2 X 1	200BKB	HCPK4	-	1
BB7-5-122	1/2 X 2	2 X 200BKB	HCPK5	-	1

Exothermic welding system

BB14 bar to bar

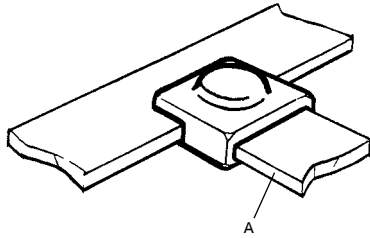

—
BB14 – For flat surfaces

Cat. no.	Bar size (in.) A	Welding powder size	Handle clamp type	Sleeve	Std. qty.
BB14-4-181	1/8 X 1	45BKB	HCPK4	-	1
BB14-4-18112	1/8 X 1 1/2	65BKB	HCPK4	-	1
BB14-4-182	1/8 X 2	90BKB	HCPK4	-	1
BB14-4-183	1/8 X 3	200BKB	HCPK4	-	1
BB14-4-184	1/8 X 4	250BKB	HCPK4	-	1
BB14-4-3161	3/16 X 1	65BKB	HCPK4	-	1
BB14-4-3162	3/16 X 2	115BKB	HCPK4	-	1
BB14-4-141	1/4 X 1	90BKB	HCPK4	-	1
BB14-4-14114	1/4 X 1 1/4	115BKB	HCPK4	-	1
BB14-4-14112	1/4 X 1 1/2	150BKB	HCPK4	-	1
BB14-4-142	1/4 X 2	200BKB	HCPK4	-	1
BB14-4-14212	1/4 X 2 1/2	250BKB	HCPK4	-	1
BB14-5-143	1/4 X 3	2 X 200BKB	HCPK5	-	1
BB14-5-144	1/4 X 4	2 X 250BKB	HCPK5	-	1
BB14-4-381	3/8 X 1	150BKB	HCPK5	-	1
BB14-4-38112	3/8 X 1 1/2	250BKB	HCPK4	-	1
BB14-5-382	3/8 X 2	2 X 150BKB	HCPK5	-	1
BB14-5-383	3/8 X 3	2 X 250BKB	HCPK5	-	1
BB14-5-384	3/8 X 4	3 X 200BKB	HCPK5	-	1
BB14-4-121	1/2 X 1	200BKB	HCPK4	-	1
BB14-5-122	1/2 X 2	2 X 200BKB	HCPK5	-	1

Exothermic welding system

BS1 and BS2 bar to steel surface

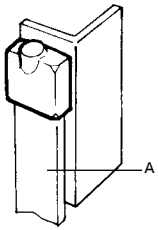
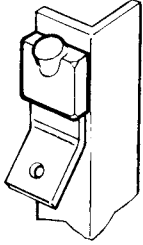

- Rectangular tape or bar

BS1 – For flat surfaces

Cat. no.	Bar size (in.) A	Welding powder size	Handle clamp type	Sleeve	Std. qty.
BS1-4-181	1/8 X 1	115BKB	HCPK4	4	1
BS1-4-18112	1/8 X 1 1/2	150BKB	HCPK4	4	1
BS1-4-182	1/8 X 2	200BKB	HCPK4	4	1
BS1-4-3161	3/16 X 1	150BKB	HCPK4	4	1
BS1-4-316112	3/16 X 1 1/2	200BKB	HCPK4	4	1
BS1-4-3162	3/16 X 2	250BKB	HCPK4	4	1
BS1-4-141	1/4 X 1	150BKB	HCPK4	4	1
BS1-4-14114	1/4 X 1 1/4	200BKB	HCPK4	4	1
BS1-4-14112	1/4 X 1 1/2	250BKB	HCPK4	4	1
BS1-5-142	1/4 X 2	2 X 150BKB	HCPK4	4	1
BS1-4-381	3/8 X 1	200BKB	HCPK5	4	1
BS1-4-38112	3/8 X 1 1/2	250BKB	HCPK4	4	1
BS1-5-382	3/8 X 2	2 X 200BKB	HCPK5	5	1
BS1-4-121	1/2 X 1	250BKB	HCPK4	4	1
BS1-5-12112	1/2 X 1 1/2	2 X 200BKB	HCPK5	5	1
BS1-5-122	1/2 X 2	2 X 250BKB	HCPK5	5	1

Mold sealing compound (MSC) will be required if surface is uneven.

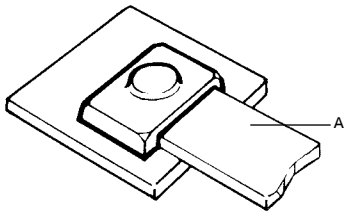

- Rectangular tape or bar

BS2 – For flat surfaces

Cat. no.	Bar size (in.) A	Welding powder size	Handle clamp type	Sleeve	Std. qty.
BS2-4-181	1/8 X 1	115BKB	HCPK4	–	1
BS2-4-18112	1/8 X 1 1/2	150BKB	HCPK4	–	1
BS2-4-182	1/8 X 2	200BKB	HCPK4	–	1
BS2-4-3161	3/16 X 1	150BKB	HCPK4	–	1
BS2-4-316112	3/16 X 1 1/2	200BKB	HCPK4	–	1
BS2-4-3162	3/16 X 2	250BKB	HCPK4	–	1
BS2-4-141	1/4 X 1	150BKB	HCPK4	–	1
BS2-4-14114	1/4 X 1 1/4	200BKB	HCPK4	–	1
BS2-4-14112	1/4 X 1 1/2	250BKB	HCPK4	–	1
BS2-5-142	1/4 X 2	2 X 150BKB	HCPK4	–	1
BS2-4-381	3/8 X 1	200BKB	HCPK5	–	1
BS2-4-38112	3/8 X 1 1/2	250BKB	HCPK4	–	1
BS2-5-382	3/8 X 2	2 X 200BKB	HCPK5	–	1
BS2-4-121	1/2 X 1	250BKB	HCPK4	–	1
BS2-5-12112	1/2 X 1 1/2	2 X 200BKB	HCPK5	–	1
BS2-5-122	1/2 X 2	2 X 250BKB	HCPK5	–	1

Mold sealing compound (MSC) will be required if surface is uneven.

Exothermic welding system

BS3 and BS4 bar to steel surface

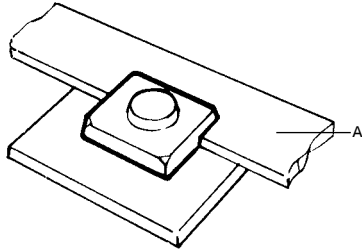

- Rectangular tape or bar

BS3 – For flat surfaces

Cat. no.	Bar size (in.) A	Welding powder size	Handle clamp type	Sleeve	Std. qty.
BS3-4-181	1/8 X 1	115BKB	HCPK4	–	1
BS3-4-18112	1/8 X 1 1/2 and wider	150BKB	HCPK4	–	1
BS3-4-3161	3/16 X 1	150BKB	HCPK4	–	1
BS3-4-316112	3/16 X 1 1/2 and wider	200BKB	HCPK4	–	1
BS3-4-141	1/4 X 1	150BKB	HCPK4	–	1
BS3-4-14114	1/4 X 1-1/4	200BKB	HCPK4	–	1
BS3-4-14112	1/4 X 1 1/2 and wider	250BKB	HCPK4	–	1
BS3-4-381	3/8 X 1	200BKB	HCPK5	–	1
BS3-4-38112	3/8 X 1 1/2 and wider	250BKB	HCPK4	–	1
BS3-4-121	1/2 X 1	250BKB	HCPK4	–	1
BS3-5-12112	1/2 X 1 1/2 and wider	2 X 200BKB	HCPK5	–	1

Mold sealing compound (MSC) will be required if surface is uneven.

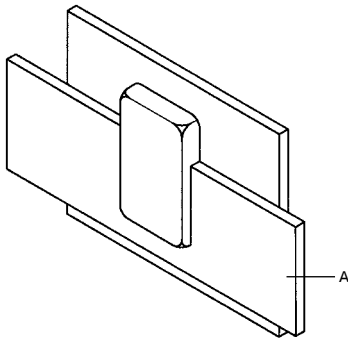

BS4 – For flat surfaces

Cat. no.	Bar size (in.) A	Welding powder size	Handle clamp type	Sleeve	Std. qty.
BS4-4-181	1/8 X 1	115BKB	HCPK4	–	1
BS4-4-18112	1/8 X 1 1/2	150BKB	HCPK4	–	1
BS4-4-182	1/8 X 2	200BKB	HCPK4	–	1
BS4-4-3161	3/16 X 1	150BKB	HCPK4	–	1
BS4-4-316112	3/16 X 1 1/2	200BKB	HCPK4	–	1
BS4-4-3162	3/16 X 2	250BKB	HCPK4	–	1
BS4-4-141	1/4 X 1	150BKB	HCPK4	–	1
BS4-4-14114	1/4 X 1 1/4	200BKB	HCPK4	–	1
BS4-4-14112	1/4 X 1 1/2	250BKB	HCPK4	–	1
BS4-5-142	1/4 X 2	2 X 150BKB	HCPK4	–	1
BS4-4-381	3/8 X 1	200BKB	HCPK5	–	1
BS4-4-38112	3/8 X 1 1/2	250BKB	HCPK4	–	1
BS4-5-382	3/8 X 2	2 X 200BKB	HCPK5	–	1
BS4-4-121	1/2 X 1	250BKB	HCPK4	–	1
BS4-5-12112	1/2 X 1 1/2	2 X 200BKB	HCPK5	–	1
BS4-5-122	1/2 X 2	2 X 250BKB	HCPK5	–	1

Mold sealing compound (MSC) will be required if surface is uneven.

Exothermic welding system

BS5 bar to steel surface

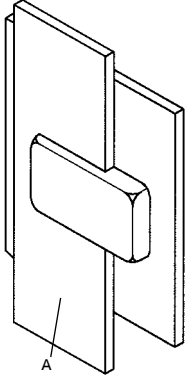

—
BS5 – For flat surfaces

Cat. no.	Bar size (in.) A	Welding powder size	Handle clamp type	Sleeve	Std. qty.
BS5-4-181	1/8 X 1	115BKB	HCPK4	–	1
BS5-4-18112	1/8 X 1 1/2	150BKB	HCPK4	–	1
BS5-4-182	1/8 X 2 and wider	200BKB	HCPK4	–	1
BS5-4-3161	3/16 X 1	150BKB	HCPK4	–	1
BS5-4-316112	3/16 X 1 1/2	200BKB	HCPK4	–	1
BS5-4-3162	3/16 X 2 and wider	250BKB	HCPK4	–	1
BS5-4-141	1/4 X 1	150BKB	HCPK4	–	1
BS5-4-14114	1/4 X 1 1/4	200BKB	HCPK4	–	1
BS5-4-14112	1/4 X 1 1/2	250BKB	HCPK4	–	1
BS5-5-142	1/4 X 2 and wider	2 X 150BKB	HCPK5	–	1
BS5-4-381	3/8 X 1	200BKB	HCPK5	–	1
BS5-4-38112	3/8 X 1 1/2	250BKB	HCPK4	–	1
BS5-5-382	3/8 X 2 and wider	2 X 200BKB	HCPK5	–	1
BS5-4-121	1/2 X 1	250BKB	HCPK4	–	1
BS5-5-12112	1/2 X 1 1/2	2 X 200BKB	HCPK5	–	1
BS5-5-122	1/2 X 2 and wider	2 X 250BKB	HCPK5	–	1

Mold sealing compound (MSC) will be required if surface is uneven.

Exothermic welding system

Handle clamps, tools and accessories

Handle clamps

Cat. no.	Description	Applications	Std. qty.
HCPK1	Price key 1 handle	For use on price key 1 molds	1
HCPK2	Price key 2 handle	For use on price key 2 molds	1
HCPK3	Price key 3 handle clamp	For use on price key 3 molds	1
HCPK3A	Price key 3A handle clamp	Type 3A molds (connections to vertical rebars)	1
HCPK3B	Price key 3B handle clamp	Type 3B molds (connections to horizontal rebars)	1
HCPK3BMOD	Price key 3B modified clamp	Type 3B molds (cross connections to horizontal rebars)	1
HCPK4	Price key 4 handle clamp	For use on price key 4 molds	1
HCPK5	Price key 5 handle clamp	For use on price key 5 molds	1
HCPK7	Price key 7 handle clamp	For use on price key 7 molds	1
HCPK8	Price key 8 handle clamp	For use on price key 8 molds	1
FRAME1	Price key 9 frame	For use with HCPK4 on price key 9 molds	1
FRAME2	Price key 10 frame	For use with HCPK5 on price key 10 molds	1

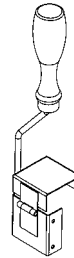

HCPK2

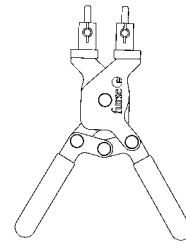

HCPK3

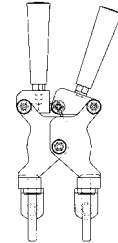

HCPK4

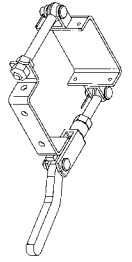

FRAME 1

Tools and accessories

Cat. no.	Description	Applications	Std. qty.
WWB1	Cable cleaning brush	Cleaning of stranded and other circular section conductors	6
WRB1	Replacement elements (pair)	-	3
BFC	Card cloth brush	Cleaning of conductors and surfaces	10
FGUN	Flint ignitor gun	Starting powder ignition	10
BCM	Mold cleaning brush	Soft brush for mold cleaning	10
STM1-TB	Mold scraper tool	Break up and removal of slag in mold crucible	10
MSC	Mold sealing compound	Mold sealing on uneven surfaces, and general mold sealing	5
PACK-A	Packing	Mold sealing on rebar surfaces	50
SLEEVE#6	Sleeve for #6 wire	Prevents burning of small section wire	100
SLEEVE#6S	Sleeve for #6s wire	Prevents burning of small section wire	100
SLEEVE#8	Sleeve for #8 wire	Prevents burning of small section wire	100
SLEEVE#8S	Sleeve for #8s wire	Prevents burning of small section wire	100
SHIM	Copper shim.	For sealing around undersize conductors	100

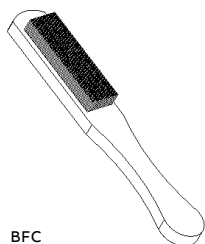

BFC

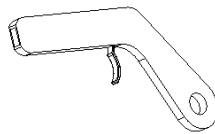

FGUN

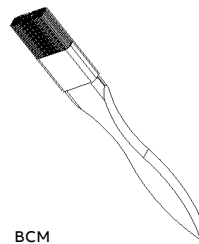

BCM



STM1-TB

Exothermic welding system

Sure Shot™ welding mold



ABB introduces a new approach to the perfect connection, Sure Shot, an extension of the Furseweld line of exothermic welding products.

Sure Shot molds come completely packaged with everything necessary for a connection. They are fast and easy to use. The contractor simply positions the mold, adds the weld powder and starting powder, and ignites it with a flint gun.

Sure Shot molds are disposable, so there's no maintenance involved. And, it's not necessary to remove the mold in underground installations because Sure Shot molds are made from an "earth-friendly" ceramic.

The hexagonal Sure Shot design is easy to grasp and hold without removing safety gloves, and it won't roll away if it's laid down while the installer prepares the connection.

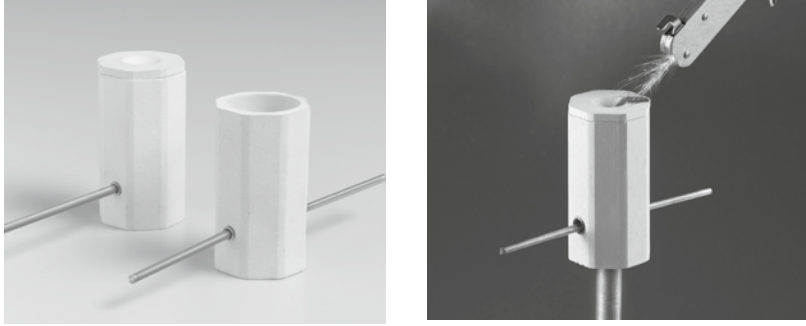
Features and benefits:

- Fast and easy to use
- Packaged with everything necessary for a connection
- Maintenance-free disposable molds
- Made of biodegradable ceramic
- Ergonomic hexagonal design

Diagrams

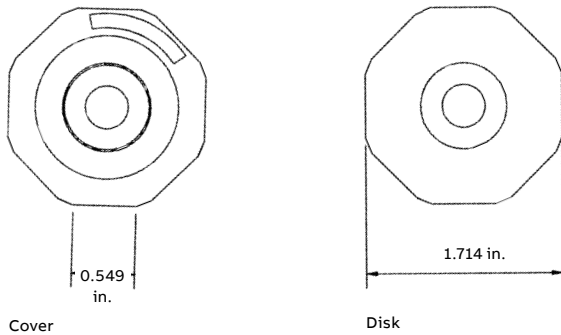

Cover

Disk

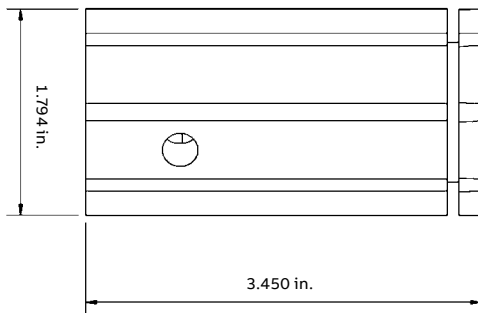

Welding mold

Exothermic welding system

Sure Shot welding mold

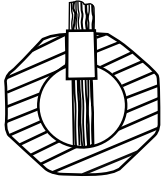

SCR1

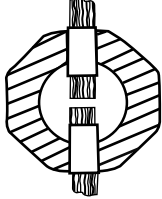

SCR2

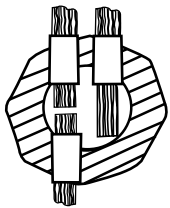

SCR17

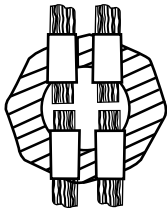

SCR24

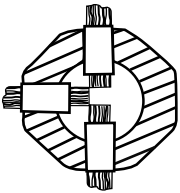

SCR25

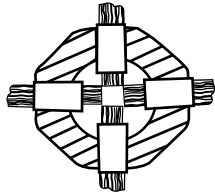

SCR27

Wire positioning

Product specifications

Cat. no.	Ground rod size (in.)	Conductor size (AWG)	
		Solid	Stranded
Furseweld type SCR1			
SCR1-58-2010	5/8	2/0, 1/0	1/0, #1
SCR1-58-0020	5/8	-	2/0
SCR1-34-6808	3/4	#6, 8	#8
SCR1-34-3446	3/4	#3, 4	#4, 6
SCR1-34-1223	3/4	#1, 2	#2, 3
SCR1-34-2010	3/4	2/0, 1/0	1/0, #1
SCR1-34-0020	3/4	-	2/0
SCR1-34-0040	3/4	-	4/0
Furseweld type SCR2			
SCR2-58-3446	5/8	#3, 4	4, 6
SCR2-58-1223	5/8	#1, 2	#2, 3
SCR2-58-0020	5/8	-	2/0
SCR2-34-3446	3/4	#3, 4	#4, 6
SCR2-34-1223	3/4	#1, 2	#2, 3
SCR2-34-0020	3/4	-	2/0
SCR2-34-0040	3/4	-	4/0
Furseweld type SCR17			
SCR17-58-1223	5/8	#1, 2	#2, 3
SCR17-34-6808	3/4	#6, 8	#8
SCR17-34-1223	3/4	#1, 2	#2, 3
Furseweld type SCR24			
SCR24-58-6808	5/8	#6, 8	#8
SCR24-58-3446	5/8	#3, 4	#4, 6
SCR24-58-1223	5/8	#1, 2	#2, 3
SCR24-34-6808	3/4	#6, 8	#8
SCR24-34-3446	3/4	#3, 4	#4, 6
SCR24-34-1223	3/4	#1, 2	#2, 3
Furseweld type SCR25			
SCR25-58-6808	5/8	#6, 8	#8
SCR25-58-3446	5/8	#3, 4	#4, 6
SCR25-34-6808	3/4	#6, 8	#8
SCR25-34-3446	3/4	#3, 4	#4, 6
SCR25-34-1223	3/4	#1, 2	#2, 3
Furseweld type SCR27			
SCR27-58-6808	5/8	#6, 8	#8
SCR27-58-3446	5/8	#3, 4	#4, 6
SCR27-34-6808	3/4	#6, 8	#8
SCR27-34-3446	3/4	#3, 4	#4, 6
SCR27-34-1223	3/4	#1, 2	#2, 3

* The weight per 100 is 20 lb and the standard carton/outer pack is 6 for all catalogue numbers.

Exothermic welding system

Cross reference

Cadweld cat. no.	Thermoweld cat. no.	Furseweld cat. no.
BAC-JE	M-1135	BB1-4-121
BAC-EE	M-1122	BB1-4-141
BAC-EG	M-1124	BB1-4-14112
BAC-EF	M-1123	BB1-4-14114
BAC-EH	M-1125	BB1-4-142
BAC-EJ	M-6346	BB1-4-14212
BAC-CE	M-1118	BB1-4-181
BAC-CG	M-2557	BB1-4-18112
BAC-CH	M-1119	BB1-4-182
BAC-CK	M-6298	BB1-4-183
BAD-CM	M-5315	BB1-4-184
BAC-DE	M-1120	BB1-4-3161
BAC-DH	M-1121	BB1-4-3162
BAC-GE	M-1130	BB1-4-381
BAC-GG	M-1131	BB1-4-38112
BAD-JH	M-1136	BB1-5-122
BAD-EK	M-1126	BB1-5-143
BAD-EM	M-1127	BB1-5-144
BAD-GH	M-1132	BB1-5-382
BAD-GK	M-1133	BB1-5-38
BAD-GM	M-1134	BB1-5-384
EPC-JE	M-1247	BB2-4-121
EPC-EE	M-1234	BB2-4-141
EPC-EG	M-1236	BB2-4-14112
EPC-EF	M-1235	BB2-4-14114
EPC-EH	M-1237	BB2-4-142
EPC-EJ	M-6352	BB2-4-14212
EPC-CE	M-1230	BB2-4-181
EPC-CG	M-6347	BB2-4-18112
EPC-CH	M-1231	BB2-4-182
EPC-CK	M-6348	BB2-4-183
EPD-CM	M-6351	BB2-4-184
EPC-DE	M-1232	BB2-4-3161
EPC-DH	M-1233	BB2-4-3162
EPC-GE	M-1242	BB2-4-381
EPC-GG	M-1243	BB2-4-38112
EPD-JH	M-1248	BB2-5-122
EPD-EK	M-1238	BB2-5-143
EPD-EM	M-1239	BB2-5-144
EPD-GH	M-1244	BB2-5-382
EPD-GK	M-1245	BB2-5-383
EPD-GM	M-1246	BB2-5-384
BQC-EEEE	M-1102	BB3-4-141
BQC-EGEG	M-1104	BB3-4-14112
BQC-EFEF	M-1103	BB3-4-14114
BQC-CECE	M-1098	BB3-4-181
BQC-CHCH	M-1099	BB3-4-182
BQC-DEDE	M-1100	BB3-4-3161
BQC-DHHD	M-1101	BB3-4-3162
BQC-GEGE	M-1108	BB3-4-381
BQD-JEJE	M-1113	BB3-5-121

Cadweld cat. no.	Thermoweld cat. no.	Furseweld cat. no.
BQD-JHJH	M-1114	BB3-5-122
BQD-EHEH	M-1105	BB3-5-142
BQD-GGGG	M-1109	BB3-5-38112
BQD-GHGH	M-1110	BB3-5-382
BQF-EKEK	M-1106	BB3-6-143
BQF-GKGK	M-1111	BB3-6-383
BWC-JE	M-1051	BS1-4-121
BWC-EE	M-1045	BS1-4-141
BWC-EG	M-1047	BS1-4-14112
BWC-EF	M-1046	BS1-4-14114
BWC-CE	M-1043	BS1-4-181
BWC-CG	M-6354	BS1-4-18112
BWC-CH	M-1044	BS1-4-182
BWC-DE	M-6056	BS1-4-3161
BWC-DG	M-6355	BS1-4-316112
BWC-DH	M-6356	BS1-4-3162
BWC-GE	M-1049	BS1-4-381
BWC-GG	M-6357	BS1-4-38112
BWD-JG	M-6358	BS1-5-12112
BWD-JH	M-1052	BS1-5-122
BWD-EH	M-1048	BS1-5-142
BWD-GH	M-1050	BS1-5-382
CGC-JE	M-1084	BS2-4-121
CGC-EE	M-1077	BS2-4-141
CGC-EG	M-1079	BS2-4-14112
CGC-EF	M-1078	BS2-4-14114
CGC-CE	M-1072	BS2-4-181
CGC-CG	M-1073	BS2-4-18112
CGC-CH	M-1074	BS2-4-182
CGC-DE	M-1075	BS2-4-3161
CGC-DG	M-6359	BS2-4-316112
CGC-DH	M-1076	BS2-4-3162
CGC-GE	M-1081	BS2-4-381
CGC-GG	M-1082	BS2-4-38112
CGD-JG	M-1085	BS2-5-12112
CGD-JH	M-1086	BS2-5-122
CGD-EH	M-1080	BS2-5-142
CGD-GH	M-1083	BS2-5-382
CHC-JE	M-1095	BS3-4-121
CHC-EE	M-1090	BS3-4-141
CHC-EG	M-1092	BS3-4-14112
CHC-EF	M-1091	BS3-4-14114
CHC-CE	M-1088	BS3-4-181
CHC-CG	M-1089	BS3-4-18112
CHC-DE	M-6353	BS3-4-3161
CHC-DG	M-7163	BS3-4-316112
CHC-GE	M-1093	BS3-4-381
CHC-GG	M-1094	BS3-4-38112
CHD-JG	M-1096	BS3-5-12112
CCC-JE	M-1060	BS4-4-121
CCC-EE	M-1056	BS4-4-141

Cadweld cat. no.	Thermoweld cat. no.	Furseweld cat. no.
CCC-EG	M-6369	BS4-4-14112
CCC-EF	M-5566	BS4-4-14114
CCC-CE	M-1054	BS4-4-181
CCC-CG	M-6360	BS4-4-18112
CCC-CH	M-1055	BS4-4-182
CCC-DE	M-6361	BS4-4-3161
CCC-DG	M-6362	BS4-4-316112
CCC-DH	M-6367	BS4-4-3162
CCC-GE	M-1058	BS4-4-381
CCC-GG	M-6370	BS4-4-38112
CCD-JG	M-6372	BS4-5-12112
CCD-JH	M-1061	BS4-5-122
CCD-EH	M-1057	BS4-5-142
CCD-GH	M-1059	BS4-5-382
CFC-JE	M-1069	BS5-4-121
CFC-EE	M-1065	BS5-4-141
CFC-EG	M-6379	BS5-4-14112
CFC-EF	M-6377	BS5-4-14114
CFC-CE	M-1063	BS5-4-181
CFC-CF	M-6373	BS5-4-18112
CFC-CH	M-1064	BS5-4-182
CFC-DE	M-6374	BS5-4-3161
CFC-DG	M-6375	BS5-4-316112
CFC-DH	M-6376	BS5-4-3162
CFC-GE	M-1067	BS5-4-381
CFC-GG	M-6382	BS5-4-38112
CFD-JG	M-6383	BS5-5-12112
CFD-JH	M-1070	BS5-5-122
CFD-EH	M-1066	BS5-5-142
CFD-GH	M-1068	BS5-5-382
LAC-1YCE	M-977	CB1-4-#1181
LAC-1VCE	M-975	CB1-4-#2181
LAC-1TCE	-	CB1-4-#2S181
LAC-1LCE	M-971	CB1-4-#4181
LAC-2CEE	M-979	CB1-4-1/0141
LAC-2CCE	M-978	CB1-4-1/0181
LAC-2CDE	M-6075	CB1-4-1/03161
LAC-2GEE	M-981	CB1-4-2/0141
LAC-2GCE	M-980	CB1-4-2/0181
LAC-2GDE	M-6579	CB1-4-2/03161
LAC-2VEE	M-988	CB1-4-250K141
LAC-2VEG	M-990	CB1-4-250K14112
LAC-2VEH	M-8784	CB1-4-250K142
LAC-2VEK	M-1916	CB1-4-250K143
LAC-2VDE	M-8277	CB1-4-250K3161
LAC-2LEE	M-983	CB1-4-3/0141
LAC-2LCE	M-6284	CB1-4-3/0181
LAC-2LDE	M-982	CB1-4-3/03161
LAC-3AEE	M-991	CB1-4-300K141
LAC-3AEG	M-993	CB1-4-300K14112
LAC-3AEH	M-6288	CB1-4-300K142

Exothermic welding system

Cross reference

Cadweld cat. no.	Thermoweld cat. no.	Furseweld cat. no.	Cadweld cat. no.	Thermoweld cat. no.	Furseweld cat. no.	Cadweld cat. no.	Thermoweld cat. no.	Furseweld cat. no.
LAC-3AEK	M-1917	CB1-4-300K143	LJC-JG1V	-	CB4-4-#212112	XBM-2V1Y	M-2718	CC11-7-250K#1
LAC-3DEE	M-994	CB1-4-350K141	LJC-EG1V	-	CB4-4-#214112	XBM-2V1V	M-2719	CC11-7-250K#2
LAC-3DEG	M-996	CB1-4-350K14112	LJC-GG1V	-	CB4-4-#238112	XBM-2V2C	M-2717	CC11-7-250K1/0
LAC-3DEH	M-6289	CB1-4-350K142	LJC-JG1T	-	CB4-4-#2S12112	XBM-2V2G	M-2716	CC11-7-250K2/0
LAC-3DEK	M-1918	CB1-4-350K143	LJC-EG1T	-	CB4-4-#2S14112	XBM-2V2V	M-2713	CC11-7-250K250K
LAC-2QEE	M-985	CB1-4-4/0141	LJC-GG1T	-	CB4-4-#2S38112	XBM-2V2L	M-2715	CC11-7-250K3/0
LAC-2QEG	M-987	CB1-4-4/014112	LJC-JG2C	M-1671	CB4-4-1/012112	XBM-2V2Q	M-2714	CC11-7-250K4/0
LAC-2QEH	M-5657	CB1-4-4/0142	LJC-EG2C	M-1651	CB4-4-1/014112	XBM-2L1Y	M-2705	CC11-7-3/0#1
LAC-2QEK	M-1915	CB1-4-4/0143	LJC-GG2C	M-1660	CB4-4-1/038112	XBM-2L1V	M-2706	CC11-7-3/0#2
LAC-2QDE	M-984	CB1-4-4/03161	LJC-JG2G	M-1672	CB4-4-2/012112	XBM-2L2C	M-2704	CC11-7-3/01/0
LAC-3QEG	M-1001	CB1-4-500K14112	LJC-EG2G	M-1652	CB4-4-2/014112	XBM-2L2G	M-2703	CC11-7-3/02/0
LAC-3QEH	M-1002	CB1-4-500K142	LJC-GG2G	M-1661	CB4-4-2/038112	XBM-2L2L	M-2702	CC11-7-3/03/0
LAC-3QEK	M-1920	CB1-4-500K143	LJC-JG2V	M-1675	CB4-4-250K12112	XBM-3A1Y	M-2726	CC11-7-300K#1
LAC-3QGG	M-1004	CB1-4-500K38112	LJC-EG2V	M-1655	CB4-4-250K14112	XBM-3A1V	M-2727	CC11-7-300K#2
LAD-4YJH	M-1011	CB1-5-1000K122	LJC-GG2V	M-1664	CB4-4-250K38112	XBM-3A2C	M-2725	CC11-7-300K1/0
LAD-4YJK	M-6295	CB1-5-1000K123	LJC-JG2L	M-1673	CB4-4-3/012112	XBM-3A2G	M-2724	CC11-7-300K2/0
LAD-4YEK	M-6292	CB1-5-1000K143	LJC-EG2L	M-1653	CB4-4-3/014112	XBM-3A2L	M-2723	CC11-7-300K3/0
LAD-4YGH	M-1009	CB1-5-1000K382	LJC-GG2L	M-1662	CB4-4-3/038112	XBM-3A2Q	M-2722	CC11-7-300K4/0
LAD-4YGK	M-1922	CB1-5-1000K383	LJC-JG3A	M-1676	CB4-4-300K12112	XBM-3D1Y	M-2735	CC11-7-350K#1
LAD-4LEH	M-1006	CB1-5-750K142	LJC-EG3A	M-1656	CB4-4-300K14112	XBM-3D1V	M-2736	CC11-7-350K#2
LAD-4LEK	M-1921	CB1-5-750K143	LJC-GG3A	M-1665	CB4-4-300K38112	XBM-3D2C	M-2734	CC11-7-350K1/0
LAD-4LGG	M-1007	CB1-5-750K38112	LJC-JG3D	M-1677	CB4-4-350K12112	XBM-3D2G	M-2733	CC11-7-350K2/0
LAD-4LGH	M-1008	CB1-5-750K382	LJC-EG3D	M-1657	CB4-4-350K14112	XBM-2Q1Y	M-2711	CC11-7-4/0#1
LAD-4LGK	M-6291	CB1-5-750K383	LJC-GG3D	M-1666	CB4-4-350K38112	XBM-2Q1V	M-2712	CC11-7-4/0#2
LQJ-JH1Y	-	CB29-10-#1122	LJC-JG2Q	M-1674	CB4-4-4/012112	XBM-2Q2C	M-2710	CC11-7-4/01/0
LQJ-EH1Y	-	CB29-10-#1142	LJC-EG2Q	M-1654	CB4-4-4/014112	XBM-2Q2G	M-2709	CC11-7-4/02/0
LQJ-GH1Y	-	CB29-10-#1382	LJC-GG2Q	M-1663	CB4-4-4/038112	XBM-2Q2L	M-2708	CC11-7-4/03/0
LQJ-JH1V	-	CB29-10-#2122	LJC-EG3Q	M-1659	CB4-4-500K14112	XBM-2Q2Q	M-2707	CC11-7-4/04/0
LQJ-JH1T	-	CB29-10-#2S122	LJC-GG3Q	M-1668	CB4-4-500K38112	XBM-3Q2C	M-2755	CC11-7-500K1/0
LQJ-JH2C	-	CB29-10-1/0122	LJD-JG4Y	M-1681	CB4-5-1000K12112	XBV-3A2V	M-2721	CC11-8-300K250K
LQJ-EH2C	-	CB29-10-1/0142	LJD-GG4Y	M-1670	CB4-5-1000K38112	XBV-3A3A	M-2720	CC11-8-300K300K
LQJ-GH2C	-	CB29-10-1/0382	LJD-JG3Q	M-1679	CB4-5-500K12112	XBV-3D2V	M-2730	CC11-8-350K250K
LQJ-JH2G	-	CB29-10-2/0122	LJD-JG4L	M-1680	CB4-5-750K12112	XBV-3D2L	M-2732	CC11-8-350K3/0
LQJ-EH2G	-	CB29-10-2/0142	LJD-GG4L	M-1669	CB4-5-750K38112	XBV-3D3A	M-2729	CC11-8-350K300K
LQJ-GH2G	-	CB29-10-2/0382	XBC-1Y1Y	M-2691	CC11-7-#1#1	XBV-3D3D	M-2728	CC11-8-350K350K
LQJ-JH2V	-	CB29-10-250K122	XBC-1Y1V	M-2692	CC11-7-#1#2	XBV-3D2Q	M-2731	CC11-8-350K4/0
LQJ-EH2V	-	CB29-10-250K142	XBC-1Y1L	M-2693	CC11-7-#1#4	XBV-3Q2G	M-2754	CC11-8-500K2/0
LQJ-GH2V	-	CB29-10-250K382	XBC-1V1V	M-2689	CC11-7-#2#2	XBV-3Q2V	M-2751	CC11-8-500K250K
LQJ-JH2Q	-	CB29-10-4/0122	XBC-1V1L	M-2690	CC11-7-#2#4	XBV-3Q2L	M-2753	CC11-8-500K3/0
LQJ-EH2Q	-	CB29-10-4/0142	XBC-1T1T	M-2689-S	CC11-7-#2S#2S	XBV-3Q3A	M-2750	CC11-8-500K300K
LQJ-GH2Q	-	CB29-10-4/0382	XBC-1L1L	M-2687	CC11-7-#4#4	XBV-3Q3D	M-2749	CC11-8-500K350K
LQJ-JH3Q	-	CB29-10-500K122	XBP-1H1H	M-5432	CC11-7-#6#6	XBV-3Q2Q	M-2752	CC11-8-500K4/0
LQJ-EH3Q	-	CB29-10-500K142	XBP-1G1G	M-5432-S	CC11-7-#6S#6S	XBV-3Q3Q	M-2747	CC11-8-500K500K
LQJ-GH3Q	-	CB29-10-500K382	XBM-2C1Y	M-2695	CC11-7-1/0#1	SST-1Y	M-5626	CC1-3-#1
LQJ-JH4L	-	CB29-10-750K122	XBM-2C1V	M-2696	CC11-7-1/0#2	SST-1X	M-5626-S	CC1-3-#1S
LQJ-EH4L	-	CB29-10-750K142	XBM-2C1L	M-2697	CC11-7-1/0#4	SST-1V	M-5625	CC1-3-#2
LQJ-GH4L	-	CB29-10-750K382	XBM-2C2C	M-2694	CC11-7-1/01/0	SST-1T	M-5625-S	CC1-3-#2S
LQE-EH1V	-	CB29-9-#2142	XBM-2G1Y	M-2700	CC11-7-2/0#1	SST-1Q	M-5624	CC1-3-#3
LQE-EH1V	-	CB29-9-#2382	XBM-2G1V	M-2701	CC11-7-2/0#2	-	-	CC1-4-#2
LQE-EH1T	-	CB29-9-#2S142	XBM-2G2C	M-2699	CC11-7-2/01/0	SSC-2C	M-205	CC1-4-1/0
LQE-EH1T	-	CB29-9-#2S382	XBM-2G2G	M-2698	CC11-7-2/02/0	SSC-2B	M-205-S	CC1-4-1/0S

Exothermic welding system

Cross reference

Cadweld cat. no.	Thermoweld cat. no.	Furseweld cat. no.
SSC-2G	M-206	CC1-4-2/0
SSC-2V	M-209	CC1-4-250K
SSC-2L	M-207	CC1-4-3/0
SSC-3A	M-210	CC1-4-300K
SSC-3D	M-211	CC1-4-350K
SSC-2Q	M-208	CC1-4-4/0
SSC-2P	M-208-S	CC1-4-4/0S
SSC-3Q	M-213	CC1-4-500K
SSD-4Y	M-215	CC1-5-1000K
SSD-4L	M-214	CC1-5-750K
TAC-1Y1Y	M-225	CC2-4-#1#1
TAC-1Y1V	M-226	CC2-4-#1#2
TAC-1Y1T	M-5879	CC2-4-#1#2S
TAC-1Y1L	M-227	CC2-4-#1#4
TAC-1V1V	M-223	CC2-4-#2#2
TAC-1V1T	M-5869	CC2-4-#2#2S
TAC-1T1L	M-224	CC2-4-#2#4
TAC-1V1L	M-5859	CC2-4-#2#4
TAC-1T1V	M-5856	CC2-4-#2S#2
TAC-1T1T	M-223-S	CC2-4-#2S#2S
TAC-1L1L	M-221	CC2-4-#4#4
TAC-2C1Y	M-229	CC2-4-1/0#1
TAC-2C1V	M-230	CC2-4-1/0#2
TAC-2C1T	M-5311	CC2-4-1/0#2S
TAC-2C1L	M-231	CC2-4-1/0#4
TAC-2C2C	M-228	CC2-4-1/01/0
TAC-4Y2C	M-308	CC2-4-1000K1/0
TAC-4Y2G	M-307	CC2-4-1000K2/0
TAC-4Y2V	M-305	CC2-4-1000K250K
TAC-4Y3A	M-304	CC2-4-1000K300K
TAC-4Y3D	M-303	CC2-4-1000K350K
TAC-4Y2Q	M-306	CC2-4-1000K4/0
TAC-2G1Y	M-234	CC2-4-2/0#1
TAC-2G1V	M-235	CC2-4-2/0#2
TAC-2G1T	M-8093	CC2-4-2/0#2S
TAC-2G1L	M-5475	CC2-4-2/0#4
TAC-2G2C	M-233	CC2-4-2/01/0
TAC-2G2G	M-232	CC2-4-2/02/0
TAC-2V1Y	M-252	CC2-4-250K#1
TAC-2V1V	M-253	CC2-4-250K#2
TAC-2V1T	M-5889	CC2-4-250K#2S
TAC-2V1L	M-5425	CC2-4-250K#4
TAC-2V2C	M-251	CC2-4-250K1/0
TAC-2V2G	M-250	CC2-4-250K2/0
TAC-2V2V	M-247	CC2-4-250K250K
TAC-2V2L	M-249	CC2-4-250K3/0
TAC-2V2Q	M-248	CC2-4-250K4/0
TAC-2L1Y	M-239	CC2-4-3/0#1
TAC-2L1V	M-240	CC2-4-3/0#2
TAC-2L1T	M-5884	CC2-4-3/0#2S
TAC-2L1L	M-5574	CC2-4-3/0#4

Cadweld cat. no.	Thermoweld cat. no.	Furseweld cat. no.
TAC-2L2C	M-238	CC2-4-3/01/0
TAC-2L2G	M-237	CC2-4-3/02/0
TAC-2L2L	M-236	CC2-4-3/03/0
TAC-3A1Y	M-260	CC2-4-300K#1
TAC-3A1V	M-261	CC2-4-300K#2
TAC-3A1T	M-5903	CC2-4-300K#2S
TAC-3A1L	M-6397	CC2-4-300K#4
TAC-3A2C	M-259	CC2-4-300K1/0
TAC-3A2G	M-258	CC2-4-300K2/0
TAC-3A2V	M-255	CC2-4-300K250K
TAC-3A2L	M-257	CC2-4-300K3/0
TAC-3A3A	M-254	CC2-4-300K300K
TAC-3A2Q	M-256	CC2-4-300K4/0
TAC-3D1Y	M-269	CC2-4-350K#1
TAC-3D1V	M-270	CC2-4-350K#2
TAC-3D1L	M-6398	CC2-4-350K#4
TAC-3D2C	M-268	CC2-4-350K1/0
TAC-3D2G	M-267	CC2-4-350K2/0
TAC-3D2V	M-264	CC2-4-350K250K
TAC-3D2L	M-266	CC2-4-350K3/0
TAC-3D3A	M-263	CC2-4-350K300K
TAC-3D3D	M-262	CC2-4-350K350K
TAC-3D2Q	M-265	CC2-4-350K4/0
TAC-2Q1Y	M-245	CC2-4-4/0#1
TAC-2Q1V	M-246	CC2-4-4/0#2
TAC-2Q1T	M-5348	CC2-4-4/0#2S
TAC-2Q1L	M-5021	CC2-4-4/0#4
TAC-2Q2C	M-244	CC2-4-4/01/0
TAC-2Q2G	M-243	CC2-4-4/02/0
TAC-2Q2L	M-242	CC2-4-4/03/0
TAC-2Q2Q	M-241	CC2-4-4/04/0
TAC-3Q1Y	M-288	CC2-4-500K#1
TAC-3Q1V	M-289	CC2-4-500K#2
TAC-3Q1L	M-8113	CC2-4-500K#4
TAC-3Q2C	M-287	CC2-4-500K1/0
TAC-3Q2G	M-286	CC2-4-500K2/0
TAC-3Q2V	M-284	CC2-4-500K250K
TAC-3Q3A	M-283	CC2-4-500K300K
TAC-3Q3D	M-282	CC2-4-500K350K
TAC-3Q2Q	M-285	CC2-4-500K4/0
TAC-3Q3Q	M-280	CC2-4-500K500K
TAC-4L2C	M-298	CC2-4-750K1/0
TAC-4L2G	M-297	CC2-4-750K2/0
TAC-4L2V	M-295	CC2-4-750K250K
TAC-4L3A	M-294	CC2-4-750K300K
TAC-4L3D	M-293	CC2-4-750K350K
TAC-4L2Q	M-296	CC2-4-750K4/0
TAD-4Y4Y	M-299	CC2-5-1000K1000K
TAD-4Y3Q	M-301	CC2-5-1000K500K
TAD-4Y4L	M-300	CC2-5-1000K750K
TAD-4L3Q	M-291	CC2-5-750K500K

Cadweld cat. no.	Thermoweld cat. no.	Furseweld cat. no.
TAD-4L4L	M-290	CC2-5-750K750K
-	-	CC2HD-4-4/04/0
XAC-1Y1Y	M-427	CC4-4-#1#1
XAC-1Y1V	M-428	CC4-4-#1#2
XAC-1Y1L	M-429	CC4-4-#1#4
XAC-1V1V	-	CC4-4-#2#2
XAC-1V1L	-	CC4-4-#2#4
XAC-1T1T	-	CC4-4-#2S#2S
XAC-1L1L	-	CC4-4-#4#4
XAC-2C1Y	M-431	CC4-4-1/0#1
XAC-2C1V	M-432	CC4-4-1/0#2
XAC-2C1L	M-433	CC4-4-1/0#4
XAC-2C2C	M-430	CC4-4-1/01/0
XAC-2G1Y	M-436	CC4-4-2/0#1
XAC-2G1V	M-437	CC4-4-2/0#2
XAC-2G2C	M-435	CC4-4-2/01/0
XAC-2G2G	M-434	CC4-4-2/02/0
XAC-2V1Y	M-454	CC4-4-250K#1
XAC-2V1V	M-455	CC4-4-250K#2
XAC-2V2C	M-453	CC4-4-250K1/0
XAC-2V2G	M-452	CC4-4-250K2/0
XAC-2V2V	M-449	CC4-4-250K250K
XAC-2V2L	M-451	CC4-4-250K3/0
XAC-2V2Q	M-450	CC4-4-250K4/0
XAC-2L1Y	M-441	CC4-4-3/0#1
XAC-2L1V	M-442	CC4-4-3/0#2
XAC-2L2C	M-440	CC4-4-3/01/0
XAC-2L2G	M-439	CC4-4-3/02/0
XAC-2L2L	M-438	CC4-4-3/03/0
XAC-3A1Y	M-462	CC4-4-300K#1
XAC-3A1V	M-463	CC4-4-300K#2
XAC-3A2C	M-461	CC4-4-300K1/0
XAC-3A2G	M-460	CC4-4-300K2/0
XAC-3A2V	M-457	CC4-4-300K250K
XAC-3A2L	M-459	CC4-4-300K3/0
XAC-3A3A	M-456	CC4-4-300K300K
XAC-3A2Q	M-458	CC4-4-300K4/0
XAC-3D1Y	M-471	CC4-4-350K#1
XAC-3D1V	M-472	CC4-4-350K#2
XAC-3D2C	M-470	CC4-4-350K1/0
XAC-3D2G	M-469	CC4-4-350K2/0
XAC-3D2L	M-466	CC4-4-350K250K
XAC-3D2V	M-468	CC4-4-350K3/0
XAC-3D3A	M-465	CC4-4-350K300K
XAC-3D3D	M-464	CC4-4-350K350K
XAC-3D2Q	M-467	CC4-4-350K4/0
XAC-2Q1Y	M-447	CC4-4-4/0#1
XAC-2Q1V	M-448	CC4-4-4/0#2
XAC-2Q2C	M-446	CC4-4-4/01/0
XAC-2Q2G	M-445	CC4-4-4/02/0
XAC-2Q2L	M-444	CC4-4-4/03/0

Exothermic welding system

Cross reference

Cadweld cat. no.	Thermoweld cat. no.	Furseweld cat. no.
XAC-2Q2Q	M-443	CC4-4-4/04/0
XAC-3Q2C	M-491	CC4-4-500K1/0
XAC-3Q2G	M-490	CC4-4-500K2/0
XAD-3Q2V	M-487	CC4-5-500K250K
XAD-3Q2L	M-489	CC4-5-500K3/0
XAD-3Q3A	M-486	CC4-5-500K300K
XAD-3Q3D	M-485	CC4-5-500K350K
XAD-3Q2Q	M-488	CC4-5-500K4/0
XAD-3Q3Q	M-483	CC4-5-500K500K
PCC-1Y1V	M-1282	CC6-4-#1#2
PCC-1Y1L	M-1283	CC6-4-#1#4
PCC-1Y1H	M-1284	CC6-4-#1#6
PCC-1Y1G	M-1285	CC6-4-#1#6S
PCC-1Y1D	M-1286	CC6-4-#1#8S
PCC-1V1V	M-1276	CC6-4-#2#2
PCC-1V1L	M-1277	CC6-4-#2#4
PCC-1V1H	M-1278	CC6-4-#2#6
PCC-1V1G	M-1279	CC6-4-#2#6S
PCC-1V1D	M-1280	CC6-4-#2#8S
PCC-1T1V	-	CC6-4-#2S#2
PCC-1T1T	-	CC6-4-#2S#2S
PCC-1T1H	-	CC6-4-#2S#6
PCC-1T1G	-	CC6-4-#2S#6S
PCC-1T2C	-	CC6-4-#2S1/0
PCC-1T2G	-	CC6-4-#2S2/0
PCC-1L1L	-	CC6-4-#4#4
PCC-1L1H	-	CC6-4-#4#6
PCC-1L1G	-	CC6-4-#4#6S
PCC-1L1D	-	CC6-4-#4#8S
PCC-2C1V	M-1289	CC6-4-1/0#2
PCC-2C1L	M-1290	CC6-4-1/0#4
PCC-2C1H	M-1291	CC6-4-1/0#6
PCC-2C1G	M-1292	CC6-4-1/0#6S
PCC-2C1D	M-1293	CC6-4-1/0#8S
PCC-2G1V	M-1297	CC6-4-2/0#2
PCC-2G1L	M-1298	CC6-4-2/0#4
PCC-2G1H	M-1299	CC6-4-2/0#6
PCC-2G1G	M-1300	CC6-4-2/0#6S
PCC-2G1D	M-1301	CC6-4-2/0#8S
-	-	CC6-4-2/02/0
PCC-2Q1Y	M-1305	CC6-4-4/0#1
PCC-2Q1V	M-1306	CC6-4-4/0#2
PCC-2Q1L	M-1307	CC6-4-4/0#4
PCC-2Q1H	M-1308	CC6-4-4/0#6
PCC-2Q1G	M-1309	CC6-4-4/0#6S
PCC-2Q1D	M-1310	CC6-4-4/0#8S
-	-	CC6-4-4/02/0
-	-	CC6-4-4/04/0
PTC-1Y1Y	M-1315	CC7-4-#1#1
PTC-1Y1X	M-6013	CC7-4-#1#1S
PTC-1Y1V	M-1316	CC7-4-#1#2

Cadweld cat. no.	Thermoweld cat. no.	Furseweld cat. no.
PTC-1Y1T	M-6017	CC7-4-#1#2S
PTC-1Y1L	M-1317	CC7-4-#1#4
PTC-1Y1H	M-5636	CC7-4-#1#6
PTC-1Y1G	M-5637	CC7-4-#1#6S
PTC-1Y1E	M-5638	CC7-4-#1#8
PTC-1Y1D	M-5639	CC7-4-#1#8S
PTC-1X1Y	M-5998	CC7-4-#1S#1
PTC-1X1V	M-6001	CC7-4-#1S#2
PTC-1X1T	M-1316-S	CC7-4-#1S#2S
PTC-1X1L	M-6008	CC7-4-#1S#4
PTC-1X1H	M-6010	CC7-4-#1S#6
PTC-1X1G	M-5636-S	CC7-4-#1S#6S
PTC-1X1E	M-6012	CC7-4-#1S#8
PTC-1X1D	M-5638-S	CC7-4-#1S#8S
PTC-1V1V	M-1313	CC7-4-#2#2
PTC-1V1L	M-1314	CC7-4-#2#4
PTC-1V1H	M-5631	CC7-4-#2#6
PTC-1V1G	M-5632	CC7-4-#2#6S
PTC-1V1E	M-5634	CC7-4-#2#8
PTC-1V1D	M-5635	CC7-4-#2#8S
PTC-1T1V	M-5973	CC7-4-#2S#2
PTC-1T1T	M-1313-S	CC7-4-#2S#2S
PTC-1T1L	M-5987	CC7-4-#2S#4
PTC-1T1H	M-5989	CC7-4-#2S#6
PTC-1T1G	M-5631-S	CC7-4-#2S#6S
PTC-1T1E	M-5993	CC7-4-#2S#8
PTC-1T1D	M-5634-S	CC7-4-#2S#8S
PTC-1L1L	M-1311	CC7-4-#4#4
PTC-1L1H	M-5627	CC7-4-#4#6
PTC-1L1G	M-8882	CC7-4-#4#6S
PTC-1L1E	M-5629	CC7-4-#4#8
PTC-1L1D	M-5630	CC7-4-#4#8S
PTC-2C1Y	M-1319	CC7-4-1/0#1
PTC-2C1X	M-6036	CC7-4-1/0#1S
PTC-2C1V	M-1320	CC7-4-1/0#2
PTC-2C1T	M-6044	CC7-4-1/0#2S
PTC-2C1L	M-1321	CC7-4-1/0#4
PTC-2C1H	M-5642	CC7-4-1/0#6
PTC-2C1G	M-1208	CC7-4-1/0#6S
PTC-2C1E	M-5644	CC7-4-1/0#8
PTC-2C1D	M-5645	CC7-4-1/0#8S
PTC-2C2C	M-1318	CC7-4-1/01/0
PTC-2C2B	M-6035	CC7-4-1/01/0S
PTC-2B1Y	M-6019	CC7-4-1/0S#1
PTC-2B1X	M-1319-S	CC7-4-1/0S#1S
PTC-2B1V	M-6023	CC7-4-1/0S#2
PTC-2B1T	M-1320-S	CC7-4-1/0S#2S
PTC-2B1L	M-6026	CC7-4-1/0S#4
PTC-2B1H	M-6806	CC7-4-1/0S#6
PTC-2B1G	M-5462-S	CC7-4-1/0S#6S
PTC-2B1E	M-6028	CC7-4-1/0S#8

Cadweld cat. no.	Thermoweld cat. no.	Furseweld cat. no.
PTC-2B1D	M-5644-S	CC7-4-1/0S#8S
PTC-2B2C	M-6227	CC7-4-1/0S1/0
PTC-2B2B	M-1318-S	CC7-4-1/0S1/0S
PTC-2G1Y	M-1324	CC7-4-2/0#1
PTC-2G1X	M-6052	CC7-4-2/0#1S
PTC-2G1V	M-1325	CC7-4-2/0#2
PTC-2G1L	M-5659	CC7-4-2/0#4
PTC-2G1H	M-5342	CC7-4-2/0#6
PTC-2G1G	M-5652	CC7-4-2/0#6S
PTC-2G1E	M-5668	CC7-4-2/0#8
PTC-2G1D	M-5943	CC7-4-2/0#8S
PTC-2G2C	M-1323	CC7-4-2/01/0
PTC-2G2B	M-6047	CC7-4-2/01/0S
PTC-2G2G	M-1322	CC7-4-2/02/0
PTC-2L1Y	M-1329	CC7-4-3/0#1
PTC-2L1X	M-6064	CC7-4-3/0#1S
PTC-2L1V	M-1330	CC7-4-3/0#2
PTC-2L1T	M-6065	CC7-4-3/0#2S
PTC-2L1L	M-6046	CC7-4-3/0#4
PTC-2L1H	M-5676	CC7-4-3/0#6
PTC-2L1G	M-5679	CC7-4-3/0#6S
PTC-2L1E	M-5680	CC7-4-3/0#8
PTC-2L1D	M-5682	CC7-4-3/0#8S
PTC-2L2C	M-1328	CC7-4-3/01/0
PTC-2L2B	M-6062	CC7-4-3/01/0S
PTC-2L2G	M-1327	CC7-4-3/02/0
PTC-2L2L	M-1326	CC7-4-3/03/0
PTC-2Q1Y	M-1335	CC7-4-4/0#1
PTC-2Q1X	M-6804	CC7-4-4/0#1S
PTC-2Q1V	M-1336	CC7-4-4/0#2
PTC-2Q1T	M-6805	CC7-4-4/0#2S
PTC-2Q1L	M-5340	CC7-4-4/0#4
PTC-2Q1H	M-5684	CC7-4-4/0#6
PTC-2Q1G	M-6552	CC7-4-4/0#6S
PTC-2Q1E	M-5686	CC7-4-4/0#8
PTC-2Q1D	M-5688	CC7-4-4/0#8S
PTC-2Q2C	M-1334	CC7-4-4/01/0
PTC-2Q2B	M-2551	CC7-4-4/01/0S
PTC-2Q2G	M-1333	CC7-4-4/02/0
PTC-2Q2L	M-1332	CC7-4-4/03/0
PTC-2Q2Q	M-1331	CC7-4-4/04/0
PTC-2Q2P	M-6803	CC7-4-4/04/0S
PTC-2P1Y	M-6089	CC7-4-4/0S#1
PTC-2P1X	M-1335-S	CC7-4-4/0S#1S
PTC-2P1V	M-6090	CC7-4-4/0S#2
PTC-2P1T	M-1336-S	CC7-4-4/0S#2S
PTC-2P1L	M-6109	CC7-4-4/0S#4
PTC-2P1H	M-6111	CC7-4-4/0S#6
PTC-2P1G	M-5684-S	CC7-4-4/0S#6S
PTC-2P1E	M-6112	CC7-4-4/0S#8
PTC-2P1D	M-5686-S	CC7-4-4/0S#8S

Exothermic welding system

Cross reference

Cadweld cat. no.	Thermoweld cat. no.	Furseweld cat. no.
PTC-2P2C	M-6085	CC7-4-4/0S1/0
PTC-2P2B	M-1334-S	CC7-4-4/0S1/0S
PTC-2P2G	M-6082	CC7-4-4/0S2/0
PTC-2P2L	M-6081	CC7-4-4/0S3/0
PTC-2P2Q	M-6071	CC7-4-4/0S4/0
PTC-2P2P	M-1331-S	CC7-4-4/0S4/0S
GRT-14A1V	-	CR1-3-500#2
GRT-14A1T	-	CR1-3-500#2S
GRT-14A1L	M-8403	CR1-3-500#4
GRT-14A1K	M-8403-S	CR1-3-500#4S
GRT-14A1H	M-8402	CR1-3-500#6
GRT-14A1G	M-8402-S	CR1-3-500#6S
GRT-14B1V	-	CR1-3-500L#2
GRT-14B1T	-	CR1-3-500L#2S
GRT-14B1L	M-8403-T	CR1-3-500L#4
GRT-14B1K	M-8403-ST	CR1-3-500L#4S
GRT-14B1H	M-8402-T	CR1-3-500L#6
GRT-14B1G	M-8402-ST	CR1-3-500L#6S
GRT-161L	M-8415	CR1-3-625#4
GRT-161K	M-8415-S	CR1-3-625#4S
GRT-161H	M-8414	CR1-3-625#6
GRT-161G	M-8414-S	CR1-3-625#6S
GRP-181L	M-8426	CR1-3-750#4
GRP-181K	M-8426-S	CR1-3-750#4S
GRT-181H	M-8422	CR1-3-750#6
GRT-181G	M-8422-S	CR1-3-750#6S
GRC-151Y	M-496	CR1-4-500#1
GRC-152C	M-497	CR1-4-5001/0
GRC-152B	M-497-S	CR1-4-5001/0S
GRC-152G	M-498	CR1-4-5002/0
GRC-152V	M-501	CR1-4-500250K
GRC-152L	M-499	CR1-4-5003/0
GRC-153A	M-502	CR1-4-500300K
GRC-152Q	M-500	CR1-4-5004/0
GRC-141Y	M-496-T	CR1-4-500L#1
GRC-142C	M-497-T	CR1-4-500L1/0
GRC-142B	M-497-ST	CR1-4-500L1/0S
GRC-142G	M-498-T	CR1-4-500L2/0
GRC-142V	M-501-T	CR1-4-500L250K
GRC-142L	M-499-T	CR1-4-500L3/0
GRC-143A	M-502-T	CR1-4-500L300K
GRC-142Q	M-500-T	CR1-4-500L4/0
GRC-161Y	M-504	CR1-4-625#1
GRC-161V	M-503	CR1-4-625#2
GRT-161V	-	CR1-4-625#2
GRC-161T	-	CR1-4-625#2S
GRT-161T	-	CR1-4-625#2S
GRC-162C	M-505	CR1-4-6251/0
GRC-162B	M-505-S	CR1-4-6251/0S
GRC-162G	M-506	CR1-4-6252/0
GRC-162V	M-509	CR1-4-625250K

Cadweld cat. no.	Thermoweld cat. no.	Furseweld cat. no.
GRC-162L	M-507	CR1-4-6253/0
GRC-163A	M-510	CR1-4-625300K
GRC-163D	M-511	CR1-4-625350K
GRC-162Q	M-508	CR1-4-6254/0
GRC-163Q	M-513	CR1-4-625500K
GRC-181Y	M-514	CR1-4-750#1
GRC-181V	M-5781	CR1-4-750#2
GRC-181T	-	CR1-4-750#2S
GRC-182C	M-515	CR1-4-7501/0
GRC-182B	M-515-S	CR1-4-7501/0S
GRC-182G	M-516	CR1-4-7502/0
GRC-182V	M-519	CR1-4-750250K
GRC-182L	M-517	CR1-4-7503/0
GRC-183A	M-520	CR1-4-750300K
GRC-183D	M-521	CR1-4-750350K
GRC-182Q	M-518	CR1-4-7504/0
GRC-183Q	M-523	CR1-4-750500K
-	-	CR17-4-7504/0
GTT-14A1L	M-8435	CR2-3-500#4
GTT-14A1K	M-8435-S	CR2-3-500#4S
GTT-14A1H	M-8434	CR2-3-500#6
GTT-14A1G	M-8434-S	CR2-3-500#6S
GTT-14B1L	M-8435-T	CR2-3-500L#4
GTT-14B1K	M-8435-ST	CR2-3-500L#4S
GTT-14B1H	M-8434-T	CR2-3-500L#6
GTT-14B1G	M-8434-ST	CR2-3-500L#6S
GTT-161L	M-8442	CR2-3-625#4
GTT-161K	M-8442-S	CR2-3-625#4S
GTT-161H	M-8441	CR2-3-625#6
GTT-161G	M-8441-S	CR2-3-625#6S
GTP-181L	M-8454	CR2-3-750#4
GTP-181K	M-8454-S	CR2-3-750#4S
GTP-181H	M-8452	CR2-3-750#6
GTP-181G	M-8452-S	CR2-3-750#6S
GTC-151Y	M-538	CR2-4-500#1
GTC-151V	M-537	CR2-4-500#2
GTC-151T	-	CR2-4-500#2S
GTC-152C	M-539	CR2-4-5001/0
GTC-152B	M-539-S	CR2-4-5001/0S
GTC-152G	M-540	CR2-4-5002/0
GTC-152V	M-543	CR2-4-500250K
GTC-152L	M-541	CR2-4-5003/0
GTC-153A	M-544	CR2-4-500300K
GTC-152Q	M-542	CR2-4-5004/0
GTC-141Y	M-538-T	CR2-4-500L#1
GTC-141V	M-537-T	CR2-4-500L#2
GTC-141T	-	CR2-4-500L#2S
GTC-142C	M-539-T	CR2-4-500L1/0
GTC-142B	-	CR2-4-500L1/0S
GTC-142G	M-540-T	CR2-4-500L2/0
GTC-142V	M-543-T	CR2-4-500L250K

Cadweld cat. no.	Thermoweld cat. no.	Furseweld cat. no.
GTC-142L	M-541-T	CR2-4-500L3/0
GTC-143A	M-544-T	CR2-4-500L300K
GTC-142Q	M-542-T	CR2-4-500L4/0
GTC-161Y	M-546	CR2-4-625#1
GTC-161V	M-545	CR2-4-625#2
GTC-161T	-	CR2-4-625#2S
GTC-162C	M-547	CR2-4-6251/0
GTC-162B	M-547-S	CR2-4-6251/0S
GTC-162G	M-548	CR2-4-6252/0
GTC-162V	M-551	CR2-4-625250K
GTC-162L	M-549	CR2-4-6253/0
GTC-163A	M-552	CR2-4-625300K
GTC-163D	M-553	CR2-4-625350K
GTC-162Q	M-550	CR2-4-6254/0
GTC-163Q	M-555	CR2-4-625500K
GTC-181Y	M-557	CR2-4-750#1
GTC-181V	M-556	CR2-4-750#2
GTC-181T	-	CR2-4-750#2S
GTC-182C	M-558	CR2-4-7501/0
GTC-182B	M-558-S	CR2-4-7501/0S
GTC-182G	M-559	CR2-4-7502/0
GTC-182V	M-562	CR2-4-750250K
GTC-182L	M-560	CR2-4-7503/0
GTC-183A	M-563	CR2-4-750300K
GTC-183D	M-564	CR2-4-750350K
GTC-182Q	M-561	CR2-4-7504/0
GTC-183Q	M-566	CR2-4-750500K
GYJ-163Q	M-1593	CR3-10-625500K
GYJ-183D	M-1599	CR3-10-750350K
GYJ-183Q	M-1601	CR3-10-750500K
GYE-152C	M-1581	CR3-9-5001/0
GYE-152B	M-1581-S	CR3-9-5001/0S
GYE-152G	M-1582	CR3-9-5002/0
GYE-152V	M-1584	CR3-9-500250K
GYE-152L	M-6267	CR3-9-5003/0
GYE-153A	M-1585	CR3-9-500300K
GYE-152Q	M-1583	CR3-9-5004/0
GYE-142C	M-1581-T	CR3-9-500L1/0
GYE-142B	M-1581-ST	CR3-9-500L1/0S
GYE-142G	M-1582-T	CR3-9-500L2/0
GYE-142V	M-1584-T	CR3-9-500L250K
GYE-142L	M-6267-T	CR3-9-500L3/0
GYE-143A	M-1585-T	CR3-9-500L300K
GYE-142Q	M-1583-T	CR3-9-500L4/0
-	-	CR3-9-625#2
GYE-162C	M-1586	CR3-9-6251/0
GYE-162B	M-1586-S	CR3-9-6251/0S
GYE-162G	M-1587	CR3-9-6252/0
GYE-162V	M-1589	CR3-9-625250K
GYE-162L	M-8305	CR3-9-6253/0
GYE-163A	M-1590	CR3-9-625300K

Exothermic welding system

Cross reference

Cadweld cat. no.	Thermoweld cat. no.	Furseweld cat. no.	Cadweld cat. no.	Thermoweld cat. no.	Furseweld cat. no.	Cadweld cat. no.	Thermoweld cat. no.	Furseweld cat. no.
GYE-163D	M-1591	CR3-9-625350K	RC	-	CRE3-4-4/OY	VBC-1Y	M-5361	CS25-4-#1
GYE-162Q	M-1588	CR3-9-6254/0	RC	-	CRE3-4-4/OZ	VBC-1Y-V3	-	CS25-4-#1C
GYE-182C	M-1594	CR3-9-7501/0	RD	-	CRE4-3-#1Y	VBC-1Y-V5	-	CS25-4-#1D
GYE-182B	M-1594-S	CR3-9-7501/0S	RD	-	CRE4-3-#1Z	VBC-1Y-V8	-	CS25-4-#1F
GYE-182G	M-1595	CR3-9-7502/0	RD	-	CRE4-3-#2SY	VBC-1Y-V21C	-	CS25-4-#1G
GYE-182V	M-1597	CR3-9-750250K	RD	-	CRE4-3-#2SZ	VBC-1V	M-2781	CS25-4-#2
GYE-182L	M-6608	CR3-9-7503/0	RD	-	CRE4-3-#2Y	VBC-1V-V3	-	CS25-4-#2C
GYE-183A	-	CR3-9-750300K	RD	-	CRE4-3-#2Z	VBC-1V-V5	-	CS25-4-#2D
GYE-182Q	M-1596	CR3-9-7504/0	RD	-	CRE4-3-#4Y	VBC-1V-V8	-	CS25-4-#2F
RR	-	CRE1-3-#1Y	RD	-	CRE4-3-#4Z	VBC-1V-V21C	-	CS25-4-#2G
RR	-	CRE1-3-#1Z	RD	-	CRE4-3-1/OY	VBC-1T	-	CS25-4-#2S
RR	-	CRE1-3-#2SY	RD	-	CRE4-3-1/OZ	VBC-1T-V3	-	CS25-4-#2SC
RR	-	CRE1-3-#2SZ	RD	-	CRE4-3-2/OY	VBC-1T-V5	-	CS25-4-#2SD
RR	-	CRE1-3-#2Y	RD	-	CRE4-3-2/OZ	VBC-1T-V8	-	CS25-4-#2SF
RR	-	CRE1-3-#2Z	RD	-	CRE4-3-3/OY	VBC-1T-V21	-	CS25-4-#2SG
RR	-	CRE1-3-#4Y	RD	-	CRE4-3-3/OZ	VBC-1L	M-5359	CS25-4-#4
RR	-	CRE1-3-#4Z	RD	-	CRE4-3-4/OY	VBC-1L-V3	-	CS25-4-#4C
RR	-	CRE1-3-1/OY	RD	-	CRE4-3-4/OZ	VBC-1L-V5	-	CS25-4-#4D
RR	-	CRE1-3-1/OZ	RJ	-	CRE6-3-#1Y	VBC-1L-V8	-	CS25-4-#4F
RR	-	CRE1-3-2/OY	RJ	-	CRE6-3-#1Z	VBC-1L-V21	-	CS25-4-#4G
RR	-	CRE1-3-2/OZ	RJ	-	CRE6-3-#2SY	VBC-2C	M-2189	CS25-4-1/0
RR	-	CRE1-3-3/OY	RJ	-	CRE6-3-#2SZ	VBC-2C-V3	-	CS25-4-1/0C
RR	-	CRE1-3-3/OZ	RJ	-	CRE6-3-#2Y	VBC-2C-V5	-	CS25-4-1/0D
RR	-	CRE1-3-4/OY	RJ	-	CRE6-3-#2Z	VBC-2C-V8	-	CS25-4-1/0F
RR	-	CRE1-3-4/OZ	RJ	-	CRE6-3-#4Y	VBC-2C-V20	-	CS25-4-1/0G
RRC-511Y	M-7503	CRE1-4-#13R	RJ	-	CRE6-3-#4Z	VBC-2G	M-2540	CS25-4-2/0
RRC-511V	M-7502	CRE1-4-#23R	RJ	-	CRE6-4-1/OY	VBC-2G-V3	-	CS25-4-2/0C
RRC-511T	-	CRE1-4-#253R	RJ	-	CRE6-4-1/OZ	VBC-2G-V5	-	CS25-4-2/0D
RRC-511L	M-7501	CRE1-4-#43R	RJ	-	CRE6-4-2/OY	VBC-2G-V8	-	CS25-4-2/0F
RRC-512C	M-7504	CRE1-4-1/03R	RJ	-	CRE6-4-2/OZ	VBC-2G-V20	-	CS25-4-2/0G
RRC-512G	M-7505	CRE1-4-2/03R	RJ	-	CRE6-4-3/OY	VBC-2V	M-8165	CS25-4-250K
RRC-512L	M-7506	CRE1-4-3/03R	RJ	-	CRE6-4-3/OZ	VBC-2L	M-5362	CS25-4-3/0
RRC-512Q	M-7507	CRE1-4-4/03R	RJ	-	CRE6-4-4/OY	VBC-2L-V3	-	CS25-4-3/0C
RC	-	CRE3-3-#2SY	RJ	-	CRE6-4-4/OZ	VBC-2L-V5	-	CS25-4-3/0D
RC	-	CRE3-3-#2SZ	HSC-2C	M-644	CS1-4-1/0	VBC-2L-V8	-	CS25-4-3/0F
RC	-	CRE3-3-#2Y	HSD-4Y	M-654	CS1-4-1000K	VBC-2L-V20	-	CS25-4-3/0G
RC	-	CRE3-3-#2Z	HSC-2G	M-645	CS1-4-2/0	VBC-3A	M-5363	CS25-4-300K
RC	-	CRE3-3-#4Y	HSC-2V	M-648	CS1-4-250K	VBC-3D	M-9029	CS25-4-350K
RC	-	CRE3-3-#4Z	HSC-2L	M-646	CS1-4-3/0	VBC-2Q	M-8718	CS25-4-4/0
-	-	CRE3-3-1/OY	HSC-3A	M-649	CS1-4-300K	VBC-2Q-V3	-	CS25-4-4/0C
-	-	CRE3-3-1/OZ	HSC-3D	M-650	CS1-4-350K	VBC-2Q-V5	-	CS25-4-4/0D
-	-	CRE3-3-2/OY	HSC-2Q	M-647	CS1-4-4/0	VBC-2Q-V8	-	CS25-4-4/0F
-	-	CRE3-3-2/OZ	HSC-3Q	M-652	CS1-4-500K	VBC-2Q-V20	-	CS25-4-4/0G
RC	-	CRE3-4-#1Y	HSD-4L	M-653	CS1-4-750K	VBR-3Q	M-8512	CS25-4-500K
RC	-	CRE3-4-#1Z	HTC-2C	M-616	CS2-4-1/0	HTD-3Q	M-624	CS2-5-500K
RC	-	CRE3-4-1/OY	HTC-2G	M-617	CS2-4-2/0	VGC-1Y	M-6279	CS27-4-#1
RC	-	CRE3-4-1/OZ	HTC-2V	M-620	CS2-4-250K	VGC-1Y-V3	-	CS27-4-#1C
RC	-	CRE3-4-2/OY	HTC-2L	M-618	CS2-4-3/0	VGC-1Y-V5	-	CS27-4-#1D
RC	-	CRE3-4-2/OZ	HTC-3A	M-621	CS2-4-300K	VGC-1Y-V8	-	CS27-4-#1F
RC	-	CRE3-4-3/OY	HTC-3D	M-622	CS2-4-350K	VGC-1Y-V21C	-	CS27-4-#1G
RC	-	CRE3-4-3/OZ	HTC-2Q	M-619	CS2-4-4/0	VGC-1V	M-5822	CS27-4-#2

Exothermic welding system

Cross reference

Cadweld cat. no.	Thermoweld cat. no.	Furseweld cat. no.
VGC-1V-V3	-	CS27-4-#2C
VGC-1V-V5	-	CS27-4-#2D
VGC-1V-V8	-	CS27-4-#2F
VGC-1V-V21C	-	CS27-4-#2G
VGC-1T	-	CS27-4-#2S
VGC-1T-V3	-	CS27-4-#2SC
VGC-1T-V5	-	CS27-4-#2SD
VGC-1T-V8	-	CS27-4-#2SF
VGC-1T-V21	-	CS27-4-#2SG
VGC-1H	M-5245	CS27-4-#4
VGC-1L	M-5816	CS27-4-#4
VGC-1L-V3	-	CS27-4-#4C
VGC-1L-V5	-	CS27-4-#4D
VGC-1L-V8	-	CS27-4-#4F
VGC-1L-V21	-	CS27-4-#4G
VGC-2C	M-1168	CS27-4-1/0
VGC-2C-V3	-	CS27-4-1/0C
VGC-2C-V5	-	CS27-4-1/0D
VGC-2C-V8	-	CS27-4-1/0F
VGC-2C-V20	-	CS27-4-1/0G
VGC-2G	M-9242	CS27-4-2/0
VGC-2G-V3	-	CS27-4-2/0C
VGC-2G-V5	-	CS27-4-2/0D
VGC-2G-V8	-	CS27-4-2/0F
VGC-2G-V20	-	CS27-4-2/0G
VGC-2V	M-2520	CS27-4-250K
VGC-2L	M-6195	CS27-4-3/0
VGC-2L-V3	-	CS27-4-3/0C
VGC-2L-V5	-	CS27-4-3/0D
VGC-2L-V8	-	CS27-4-3/0F
VGC-2L-V20	-	CS27-4-3/0G
VGC-2Q	M-2177	CS27-4-4/0
VGC-2Q-V3	-	CS27-4-4/0C
VGC-2Q-V5	-	CS27-4-4/0D
VGC-2Q-V8	-	CS27-4-4/0F
VGC-2Q-V20	-	CS27-4-4/0G
VNC-1Y	M-6060	CS31-4-#1
VGC-1Y-V3	-	CS31-4-#1C
VGC-1Y-V5	-	CS31-4-#1D
VGC-1Y-V8	-	CS31-4-#1F
VGC-1Y-V21C	-	CS31-4-#1G
VNC-1V	M-2569	CS31-4-#2
VGC-1V-V3	-	CS31-4-#2C
VGC-1V-V5	-	CS31-4-#2D
VGC-1V-V8	-	CS31-4-#2F
VGC-1V-V21C	-	CS31-4-#2G
VNC-1T	-	CS31-4-#2S
VGC-1T-V3	-	CS31-4-#2SC
VGC-1T-V5	-	CS31-4-#2SD
VGC-1T-V8	-	CS31-4-#2SF
VGC-1T-V21	-	CS31-4-#2SG

Cadweld cat. no.	Thermoweld cat. no.	Furseweld cat. no.
VNC-1L	M-2761	CS31-4-#4
VGC-1L-V3	-	CS31-4-#4C
VGC-1L-V5	-	CS31-4-#4D
VGC-1L-V8	-	CS31-4-#4F
VGC-1L-V21	-	CS31-4-#4G
VNC-1H	M-5910	CS31-4-#6
VNC-2C	M-5419	CS31-4-1/0
VGC-2C-V3	-	CS31-4-1/0C
VGC-2C-V5	-	CS31-4-1/0D
VGC-2C-V8	-	CS31-4-1/0F
VGC-2C-V20	-	CS31-4-1/0G
VNC-2G	M-2567	CS31-4-2/0
VGC-2G-V3	-	CS31-4-2/0C
VGC-2G-V5	-	CS31-4-2/0D
VGC-2G-V8	-	CS31-4-2/0F
VGC-2G-V20	-	CS31-4-2/0G
VNC-2V	M-2568	CS31-4-250K
VNC-2L	M-6072	CS31-4-3/0
VGC-2L-V3	-	CS31-4-3/0C
VGC-2L-V5	-	CS31-4-3/0D
VGC-2L-V8	-	CS31-4-3/0F
VGC-2L-V20	-	CS31-4-3/0G
VNC-3A	M-6061	CS31-4-300K
VNC-3D	M-6067	CS31-4-350K
VNC-2Q	M-9253	CS31-4-4/0
VGC-2Q-V3	-	CS31-4-4/0C
VGC-2Q-V5	-	CS31-4-4/0D
VGC-2Q-V8	-	CS31-4-4/0F
VGC-2Q-V20	-	CS31-4-4/0G
VNC-3Q	M-8359	CS31-4-500K
HAA-1Y-325C	M-6269	CS32-2-#1D
HAA-1Y-7C	M-6270	CS32-2-#1F
HAA-1Y-11C	M-6271	CS32-2-#1G
HAA-1V-162C	M-6016	CS32-2-#2C
HAA-1V-350C	M-2576	CS32-2-#2D
HAA-1V-7C	M-2514	CS32-2-#2F
HAA-1V-11C	M-2515	CS32-2-#2G
HAA-1T-162C	-	CS32-2-#2SC
HAA-1T-350C	-	CS32-2-#2SD
HAA-1T-7C	-	CS32-2-#2SF
HAA-1T-11C	-	CS32-2-#2SG
HAA-1L-162C	M-8014	CS32-2-#4C
HAA-1L-350C	M-8015	CS32-2-#4D
HAA-1L-7C	M-2516	CS32-2-#4F
HAA-1L-11C	M-2517	CS32-2-#4G
HAH-2C-350C	M-8504	CS32-4-1/0D
HAH-2C-8C	M-8505	CS32-4-1/0F
HAH-2C-20C	M-6272	CS32-4-1/0G
HAH-2G-350C	M-2776	CS32-4-2/0D
HAH-2G-8C	M-6273	CS32-4-2/0F
HAH-2G-20C	M-6274	CS32-4-2/0G

Cadweld cat. no.	Thermoweld cat. no.	Furseweld cat. no.
HAH-2L-350C	M-6275	CS32-4-3/0D
HAH-2L-8C	M-6276	CS32-4-3/0F
HAH-2L-20C	M-6278	CS32-4-3/0G
HAH-2Q-350C	M-9236	CS32-4-4/0D
HAH-2Q-8C	M-9237	CS32-4-4/0F
HAH-2Q-20C	M-9238	CS32-4-4/0G
VSC-1Y	M-589	CS3-4-#1
VSC-1Y-V3C	M-2482	CS3-4-#1C
VSC-1Y-V5C	M-2483	CS3-4-#1D
VSC-1Y-V8C	M-2484	CS3-4-#1F
VSC-1Y-V21C	M-2485	CS3-4-#1G
VSC-1V	M-588	CS3-4-#2
VSC-1V-V3C	M-9233	CS3-4-#2C
VSC-1V-V5C	M-2480	CS3-4-#2D
VSC-1V-V8C	M-2583	CS3-4-#2F
VSC-1V-V21C	M-2481	CS3-4-#2G
VSC-1T	-	CS3-4-#2S
VSC-1T-V3C	-	CS3-4-#2SC
VSC-1T-V5C	-	CS3-4-#2SD
VSC-1T-V8C	-	CS3-4-#2SF
VSC-1T-V21C	-	CS3-4-#2SG
VSC-1L	M-586	CS3-4-#4
VSC-1L-V3C	M-2476	CS3-4-#4C
VSC-1L-V5C	M-2477	CS3-4-#4D
VSC-1L-V8C	M-2478	CS3-4-#4F
VSC-1L-V21C	M-2479	CS3-4-#4G
VSC-1H	M-585	CS3-4-#6
VSC-2C	M-590	CS3-4-1/0
VSC-2C-V3C	M-2486	CS3-4-1/0C
VSC-2C-V5C	M-2487	CS3-4-1/0D
VSC-2C-V8C	M-2488	CS3-4-1/0F
VSC-2C-V21C	M-2489	CS3-4-1/0G
HCA-1Y-350C	-	CS34-2-#1D
HCA-1Y-7C	-	CS34-2-#1F
HCA-1Y-11C	-	CS34-2-#1G
HCA-1V-162C	-	CS34-2-#2C
HCA-1V-350C	-	CS34-2-#2D
HCA-1V-7C	-	CS34-2-#2F
HCA-1V-11C	-	CS34-2-#2G
HCA-1T-162C	-	CS34-2-#2SC
HCA-1T-350C	-	CS34-2-#2SD
HCA-1T-7C	-	CS34-2-#2SF
HCA-1T-11C	-	CS34-2-#2SG
HCA-1L-162C	-	CS34-2-#4C
HCA-1L-350C	-	CS34-2-#4D
HCA-1L-7C	-	CS34-2-#4F
HCA-1L-11C	-	CS34-2-#4G
VSC-2G	M-591	CS3-4-2/0
VSC-2G-V3C	M-8833	CS3-4-2/0C
VSC-2G-V5C	M-2490	CS3-4-2/0D
VSC-2G-V8C	M-2491	CS3-4-2/0F

Exothermic welding system

Cross reference

Cadweld cat. no.	Thermoweld cat. no.	Furseweld cat. no.	Cadweld cat. no.	Thermoweld cat. no.	Furseweld cat. no.	Cadweld cat. no.	Thermoweld cat. no.	Furseweld cat. no.
VSC-2G-V21C	M-2492	CS3-4-2/0G	VVR-2C-V3	-	CS4-5-1/0C	VFR-2L	M-1642	CS7-5-3/0
VSC-2V	M-594	CS3-4-250K	VVR-2C-V5	-	CS4-5-1/0D	VFR-2L-V3	-	CS7-5-3/0C
VSC-2L	M-592	CS3-4-3/0	VVR-2C-V8	-	CS4-5-1/0F	VFR-2L-V5	-	CS7-5-3/0D
VSC-2L-V3C	M-2493	CS3-4-3/0C	VVR-2C-V20	-	CS4-5-1/0G	VFR-2L-V8	-	CS7-5-3/0F
VSC-2L-V5C	M-2494	CS3-4-3/0D	VVR-2G	M-1221	CS4-5-2/0	VFR-2L-V20	-	CS7-5-3/0G
VSC-2L-V8C	M-2495	CS3-4-3/0F	VVR-2G-V3	-	CS4-5-2/0C	VFR-3A	M-1645	CS7-5-300K
VSC-2L-V21C	M-2496	CS3-4-3/0G	VVR-2G-V5	-	CS4-5-2/0D	VFR-2Q	M-1643	CS7-5-4/0
VSC-3A	M-595	CS3-4-300K	VVR-2G-V8	-	CS4-5-2/0F	VFR-2Q-V3	-	CS7-5-4/0C
VSC-3D	M-596	CS3-4-350K	VVR-2G-V20	-	CS4-5-2/0G	VFR-2Q-V5	-	CS7-5-4/0D
VSC-2Q	M-593	CS3-4-4/0	VVR-2V	M-1224	CS4-5-250K	VFR-2Q-V8	-	CS7-5-4/0F
VSC-2Q-V3C	M-9021	CS3-4-4/0C	VVR-2L	M-1222	CS4-5-3/0	VFR-2Q-V20	-	CS7-5-4/0G
VSC-2Q-V5C	M-2497	CS3-4-4/0D	VVR-2L-V3	-	CS4-5-3/0C	VFF-3D	M-1646	CS7-6-350K
VSC-2Q-V8C	M-2498	CS3-4-4/0F	VVR-2L-V5	-	CS4-5-3/0D	VFF-3Q	M-1648	CS7-6-500K
VSC-2Q-V21C	M-2499	CS3-4-4/0G	VVR-2L-V8	-	CS4-5-3/0F	HAA-1Y	M-631	CS8-2-#1
HTC-2C-350C	-	CS34-4-1/0D	VVR-2L-V20	-	CS4-5-3/0G	HAA-1V	M-630	CS8-2-#2
HTC-2C-8C	-	CS34-4-1/0F	VVR-2Q	M-1223	CS4-5-4/0	HAA-1T	-	CS8-2-#2S
HTC-2C-20C	-	CS34-4-1/0G	VVR-2Q-V3	-	CS4-5-4/0C	HAA-1L	M-629	CS8-2-#4
HTC-2G-350C	-	CS34-4-2/0D	VVR-2Q-V5	-	CS4-5-4/0D	HAA-1H	M-628	CS8-2-#6
HTC-2G-8C	-	CS34-4-2/0F	VVR-2QV8	-	CS4-5-4/0F	HCA-1Y	M-605	CS9-2-#1
HTC-2G-20C	-	CS34-4-2/0G	VVR-2Q-V20	-	CS4-5-4/0G	HCA-1V	M-604	CS9-2-#2
HTC-2L-350C	-	CS34-4-3/0D	VFC-1Y	M-1639	CS7-4-#1	HCA-1T	-	CS9-2-#2S
HTC-2L-8C	-	CS34-4-3/0F	VFC-1Y-V3	-	CS7-4-#1C	HCA-1L	M-603	CS9-2-#4
HTC-2L-20C	-	CS34-4-3/0G	VFC-1Y-V5	-	CS7-4-#1D	HCA-1H	M-602	CS9-2-#6
HTC-2Q-350C	-	CS34-4-4/0D	VFC-1Y-V8	-	CS7-4-#1F	15	15	15BKB
HTC-2Q-8C	-	CS34-4-4/0F	VFC-1Y-V21	-	CS7-4-#1G	25	25	25BKB
HTC-2Q-20C	-	CS34-4-4/0G	VFC-1V	M-1638	CS7-4-#2	32	32	32BKB
VSC-3Q	M-598	CS3-4-500K	VFC-1V-V3	-	CS7-4-#2C	45	45	45BKB
VSD-4Y	M-600	CS3-5-1000K	VFC-1V-V5	-	CS7-4-#2D	65	65	65BKB
VSD-4L	M-599	CS3-5-750K	VFC-1V-V8	-	CS7-4-#2F	90	90	90BKB
VVC-1Y	M-1219	CS4-4-#1	VFC-1V-V21	-	CS7-4-#2G	115	115	115BKB
VVC-1Y-V3	-	CS4-4-#1C	VFC-1T	-	CS7-4-#2S	150	150	150BKB
VVC-1Y-V5	-	CS4-4-#1D	VFC-1T-V3	-	CS7-4-#2SC	200	200	200BKB
VVC-1Y-V8	-	CS4-4-#1F	VFC-1T-V5	-	CS7-4-#2SD	250	250	250BKB
VVC-1Y-V21	-	CS4-4-#1G	VFC-1T-V8	-	CS7-4-#2SF	L160	40-0106-00	HCPK4
VVC-1V	M-1218	CS4-4-#2	VFC-1T-V21	-	CS7-4-#2SG	L159	40-0107-00	HCPK5
VVC-1V-V3	-	CS4-4-#2C	VFC-1L	M-1636	CS7-4-#4	T314	38-0135-00	WWB1
VVC-1V-V5	-	CS4-4-#2D	VFC-1L-V3	-	CS7-4-#4C	T314A	38-0135-01	WRB1
VVC-1V-V8	-	CS4-4-#2F	VFC-1L-V5	-	CS7-4-#4D	T313	38-0306-00	BFC
VVC-1V-V21	-	CS4-4-#2G	VFC-1L-V8	-	CS7-4-#4F	T320	38-0309-00	FGUN
VVC-1T	-	CS4-4-#2S	VFC-1L-V21	-	CS7-4-#4G	T394	38-3922-00	BCM
VVC-1T-V3	-	CS4-4-#2SC	VFC-2C	M-1640	CS7-4-1/0	B136A/B	40-0319-01/3/5/6	STM1
VVC-1T-V5	-	CS4-4-#2SD	VFC-2C-V3	-	CS7-4-1/0C	T403	38-4129-00	MSC
VVC-1T-V8	-	CS4-4-#2SF	VFC-2C-V5	-	CS7-4-1/0D	B144A/B/C/E	38-406-1/2/3/4-00	PACK-A
VVC-1T-V21	-	CS4-4-#2SG	VFC-2C-V8	-	CS7-4-1/0F			
VVC-1L	M-1216	CS4-4-#4	VFC-2C-V20	-	CS7-4-1/0G			
VVC-1L-V3	-	CS4-4-#4C	VFC-2G	M-1641	CS7-4-2/0			
VVC-1L-V5	-	CS4-4-#4D	VFC-2G-V3	-	CS7-4-2/0C			
VVC-1L-V8	-	CS4-4-#4F	VFC-2G-V5	-	CS7-4-2/0D			
VVC-1L-V21	-	CS4-4-#4G	VFC-2G-V8	-	CS7-4-2/0F			
VVC-1H	M-1215	CS4-4-#6	VFC-2G-V20	-	CS7-4-2/0G			
VVR-2C	M-1220	CS4-5-1/0	VFR-2V	M-1644	CS7-5-250K			

Exothermic welding system

Sure Shot cross reference

Ground rod Size (in.)	Conductor size (AWG or kcmil)		Cadweld cat. no.	Thermoweld cat. no.	Furseweld cat. no.
	Solid	Stranded	TYPE GR(CR1)	TYPE CR-1	TYPE CR1
½	#6, 8	#8	GR1-141G	-	-
	#3, 4	#4, 6	GR1-141L	-	-
	#1, 2	#2, 3	GR1-141V	-	-
⅝	#6, 8	#8	GR1-161G	M-2012	SCR1-58-6808
	#3, 4	#4, 6	GR1-161L	M-2013	SCR1-58-3446
	#1, 2	#2, 3	GR1-161V	M-2014	SCR1-58-1223
	2/0, 1/0	1/0, #1	GR1-162C	M-2015	SCR1-58-2010
	-	2/0	GR1-162G	M-2016	SCR1-58-0020
¾	#6, 8	#8	GR1-181G	M-2017	SCR1-34-6808
	#3, 4	#4, 6	GR1-181L	M-2018	SCR1-34-3446
	#1, 2	#2, 3	GR1-181V	M-2019	SCR1-34-1223
	2/0, 1/0	1/0, #1	GR1-182C	M-2020	SCR1-34-2010
	-	2/0	GR1-182G	M-2021	SCR1-34-0020
	-	4/0	GR1-182Q	-	SCR1-34-0040
Size (in.)	Solid	Stranded	TYPE GT(CR2)	TYPE CR-2	TYPE CR2
½	#6, 8	#8	GT1-141G	-	-
	#3, 4	#4, 6	GT1-141L	-	-
	#1, 2	#2, 3	GT1-141V	-	-
⅝	#6, 8	#8	GT1-161G	M-2027	SCR2-58-6808
	#3, 4	#4, 6	GT1-161L	M-2028	SCR2-58-3446
	#1, 2	#2, 3	GT1-161V	M-2029	SCR2-58-1223
	2/0, 1/0	1/0, #1	GT1-162C	M-2030	SCR2-58-2010
	-	2/0	-	-	SCR2-58-0020*
¾	#6, 8	#8	GT1-181G	M-2031	SCR2-34-6808
	#3, 4	#4, 6	GT1-181L	M-2032	SCR2-34-3446
	#1, 2	#2, 3	GT1-181V	M-2033	SCR2-34-1223
	2/0, 1/0	1/0, #1	GT1-182C	M-2034	SCR2-34-2010
	-	2/0	-	-	SCR2-34-0020*
	-	4/0	-	-	SCR2-34-0040*
Size (in.)	Solid	Stranded	TYPE NT(CR17)		TYPE CR17
½	#6, 8	#8	NT1-141G	-	-
	#3, 4	#4, 6	NT1-141L	-	-
	#1, 2	#2, 3	-	-	-
⅝	#6, 8	#8	NT1-161G	-	SCR17-58-6808
	#3, 4	#4, 6	NT1-161L	-	SCR17-58-3446
	#1, 2	#2, 3	NT1-161V	-	SCR17-58-1223
	2/0, 1/0	1/0, #1	-	-	SCR17-58-2010*
	-	2/0	-	-	SCR17-58-0020*
¾	#6, 8	#8	NT1-181G	-	SCR17-34-6808
	#3, 4	#4, 6	NT1-181L	-	SCR17-34-3446
	#1, 2	#2, 3	NT1-181V	-	SCR17-34-1223
	2/0, 1/0	1/0, #1	-	-	SCR17-34-2010*
	-	2/0	-	-	SCR17-34-0020*
	-	4/0	-	-	SCR17-34-0040*
Size (in.)	Solid	Stranded	TYPE NX(CR24)		TYPE CR24
½	#6, 8	#8	NX1-141G	-	-
	#3, 4	#4, 6	NX1-141L	-	-
	#1, 2	#2, 3	-	-	-
⅝	#6, 8	#8	NX1-161G	-	SCR24-58-6808
	#3, 4	#4, 6	NX1-161L	-	SCR24-58-3446

* Future development.

Exothermic welding system

Sure Shot cross reference

Ground rod	Conductor size (AWG or kcmil)		Cadweld cat. no.	Thermoweld cat. no.	Furseweld cat. no.
Size (in.)	Solid	Stranded	TYPE GR(CR1)	TYPE CR-1	TYPE CR1
3/4	#3, 4	#4, 6	NX1-181L	-	SCR24-34-3446
	#1, 2	#2, 3	NX1-181V	-	SCR24-34-1223
	2/0, 1/0	1/0, #1	-	-	SCR24-34-2010*
5/8	-	2/0	-	-	SCR24-34-0020*
	-	4/0	-	-	SCR24-34-0040*
Size (in.)	Solid	Stranded		TYPE CR-25	TYPE CR25
	#6, 8	#8	-	M-2006	SCR25-58-6808
	#3, 4	#4, 6	-	M-2007	SCR25-58-3446
	#1, 2	#2, 3	-	M-2008	SCR25-58-1223
3/4	2/0, 1/0	1/0, #1	-	M-2023	SCR25-58-12010
	#6, 8	#8	-	M-2068	SCR25-34-6808
	#3, 4	#4, 6	-	M-2069	SCR25-34-3446

* Future development.

Exothermic welding system

Additional tables

Conductor properties

Size (AWG or kcmil)	Area		Conductors							Direct-current resistance at 75 °C (167 °F)					
			Stranding			Overall				Copper					
	mm ²	Circular mils	Quantity	Diameter		Diameter		Area mm ²	Area in. ²	Uncoated		Coated		Aluminum	
				mm	in.	mm	in.			ohm/ km	ohm/ kFT	ohm/ km	ohm/ kFT	ohm/ km	ohm/ kFT
18	0.823	1,620	1	-	-	1.02	0.040	0.823	0.001	25.5	7.77	26.5	8.08	42.0	12.8
	0.823	1,620	7	0.39	0.015	1.16	0.046	1.06	0.002	26.1	7.95	27.7	8.45	42.8	13.1
16	1.31	2,580	1	-	-	1.29	0.051	1.31	0.002	16.0	4.89	16.7	5.08	26.4	8.05
	1.31	2,580	7	0.49	0.019	1.46	0.058	1.68	0.003	16.4	4.99	17.3	5.29	26.9	8.21
14	2.08	4,110	1	-	-	1.63	0.064	2.08	0.003	10.1	3.07	10.4	3.19	16.6	5.06
	2.08	4,110	7	0.62	0.024	1.85	0.073	2.68	0.004	10.3	3.14	10.7	3.26	16.9	5.17
12	3.31	6,530	1	-	-	2.05	0.081	3.31	0.005	6.34	1.93	6.57	2.01	10.45	3.18
	3.31	6,530	7	0.78	0.030	2.32	0.092	4.25	0.006	6.50	1.98	6.73	2.05	10.69	3.25
10	5.261	10,380	1	-	-	2.588	0.102	5.26	0.008	3.984	1.21	4.148	1.26	6.561	2.00
	5.261	10,380	7	0.98	0.038	2.95	0.116	6.76	0.011	4.070	1.24	4.226	1.29	6.679	2.04
8	8.367	16,510	1	-	-	3.264	0.128	8.37	0.013	2.506	0.764	2.579	0.786	4.125	1.26
	8.367	16,510	7	1.23	0.049	3.71	0.146	10.76	0.017	2.551	0.778	2.653	0.809	4.204	1.28
6	13.30	26,240	7	1.56	0.061	4.67	0.184	17.09	0.027	1.608	0.491	1.671	0.510	2.652	0.808
4	21.15	41,740	7	1.96	0.077	5.89	0.232	27.19	0.042	1.010	0.308	1.053	0.321	1.666	0.508
3	26.67	52,620	7	2.20	0.087	6.60	0.260	34.28	0.053	0.802	0.245	0.833	0.254	1.320	0.403
2	33.62	66,360	7	2.47	0.097	7.42	0.292	43.23	0.067	0.634	0.194	0.661	0.201	1.045	0.319
1	42.41	83,690	19	1.69	0.066	8.43	0.332	55.80	0.087	0.505	0.154	0.524	0.160	0.829	0.253
1/0	53.49	105,600	19	1.89	0.074	9.45	0.372	70.41	0.109	0.399	0.122	0.415	0.127	0.660	0.201
2/0	67.43	133,100	19	2.13	0.084	10.62	0.418	88.74	0.137	0.3170	0.0967	0.329	0.101	0.523	0.159
3/0	85.01	167,800	19	2.39	0.094	11.94	0.470	111.9	0.173	0.2512	0.0766	0.2610	0.0797	0.413	0.126
4/0	107.2	211,600	19	2.68	0.106	13.41	0.528	141.1	0.219	0.1996	0.0608	0.2050	0.0626	0.328	0.100
250	-	-	37	2.09	0.082	14.61	0.575	168	0.260	0.1687	0.0515	0.1753	0.0535	0.2778	0.0847
300	-	-	37	2.29	0.090	16.00	0.630	201	0.312	0.1409	0.0429	0.1463	0.0446	0.2318	0.0707
350	-	-	37	2.47	0.097	17.30	0.681	235	0.364	0.1205	0.0367	0.1252	0.0382	0.1984	0.0605
400	-	-	37	2.64	0.104	18.49	0.728	268	0.416	0.1053	0.0321	0.1084	0.0331	0.1737	0.0529
500	-	-	37	2.95	0.116	20.65	0.813	336	0.519	0.0845	0.0258	0.0869	0.0265	0.1391	0.0424
600	-	-	-	2.52	0.099	22.68	0.893	404	0.626	0.0704	0.0214	0.0732	0.0223	0.1159	0.0353
700	-	-	61	2.72	0.107	24.49	0.964	471	0.730	0.0603	0.0184	0.0622	0.0189	0.0994	0.0303
750	-	-	61	2.82	0.111	25.35	0.998	505	0.782	0.0563	0.0171	0.0579	0.0176	0.0927	0.0282
800	-	-	61	2.91	0.114	26.16	1.030	538	0.834	0.0528	0.0161	0.0544	0.0166	0.0868	0.0265
900	-	-	61	3.09	0.122	27.79	1.094	606	0.940	0.0470	0.0143	0.0481	0.0147	0.0770	0.0235
1000	-	-	61	3.25	0.128	29.26	1.152	673	1.042	0.0423	0.0129	0.0434	0.0132	0.0695	0.0212

FPN: The construction information is per NEMA WC8-1992 or ANSI/UL 1581-1998. The resistance is calculated per National Bureau of Standards Handbook 100, dated 1966, and Handbook 109, dated 1972. 70-625 TABLES.

Exothermic welding system

Additional tables

Metric conductors

Wire size		Circ mils	# of strands	Strand diameter	Diameter		Colour code	Die code
mm	AWG				mm	Inch		
10	8	19,73	1	3.57	3.57	0.140	Red	21
10	8	19,73	7	1.35	4.05	0.159	Red	21
16	6	31,558	1	4.50	4.50	0.177	Blue	24
16	6	31,558	7	1.70	5.10	0.200	Blue	24
25	2	49,325	7	2.14	6.42	0.253	Gray	29
25	2	49,325	19	1.35	6.75	0.266	Brown	33
35	1	69,055	19	1.53	7.65	0.300	Green	37
50	1/0	98,65	19	1.78	8.90	0.350	Pink	42
70	2/0	138,11	19	2.14	10.70	0.421	Black	45
95	3/0	187,5	19	2.52	12.60	0.496	Orange	50
95	3/0	187,5	37	1.78	12.46	0.490	Orange	50
120	250	236,76	37	2.03	14.21	0.560	Purple	54
150	300	295,95	37	2.25	15.75	0.620	White	66
185	-	365	61	2.52	17.64	0.695	Red	71
240	500	473,5	61	2.25	20.25	0.797	Brown	87
300	-	591,9	61	2.52	22.68	0.893	Green	94
400	-	789,2	61	2.85	25.65	1.000	Black	106
400	-	789,2	91	2.36	25.96	1.022	Black	106
500	-	986,5	61	3.20	28.80	1.134	-	125
500	-	986,5	91	2.65	29.15	1.148	-	-
630	-	1,243,000	127	2.52	32.76	1.290	-	-
800	-	1,578,400	127	2.85	37.05	1.459	-	-
1,000	-	1,973,000	127	3.20	41.60	1.638	-	-

Exothermic welding system

Additional tables

Table B.310.1 ampacities of two or three insulated conductors, rated 0 through 2000 V, within an overall covering (multiconductor cable), in raceway in free air based on ambient air temperature of 30 °C (86 °F)

Temperature rating of conductor

Size (AWG or kcmil)	60 °C (140 °F)	75 °C (167 °F)	90 °C (194 °F)	60 °C (140 °F)	75 °C (167 °F)	90 °C (194 °F)	Size (AWG or kcmil)
	Types TW, UF	Types RHW, THHW, THW, THWN, XHHW, ZW Copper	Types THHN, THHW, THW-2, THWN-2, RHH, RWH-2, USE-2, XHHN, XHHW-2, ZW-2	Type TW	Types RHW, THHW, THW, THWN, XHHW	Types THHN, THHW, THW-2, THWN-2, RHH, RWH-2, USE-2, XHHW, XHHW, XHHW-2, ZW-2	
14	16*	18*	21*	–	–	–	14
12	20*	24*	27*	16*	18*	21*	12
10	27*	33*	36*	21*	25*	28*	10
8	36	43	48	28	33	37	8
6	48	58	65	38	45	51	6
4	66	79	89	51	61	69	4
3	76	90	102	59	70	79	3
2	88	105	119	69	83	93	2
1	102	121	137	80	95	106	1
1/0	121	145	163	94	113	127	1/0
2/0	138	166	186	108	129	146	2/0
3/0	158	189	214	124	147	167	3/0
4/0	187	223	253	147	176	197	4/0
250	205	245	276	160	192	217	250
300	234	281	317	185	221	250	300
350	255	305	345	202	242	273	350
400	274	328	371	218	261	295	400
500	315	378	427	254	303	342	500
600	343	413	468	279	335	378	600
700	376	452	514	310	371	420	700
750	387	466	529	321	384	435	750
800	397	479	543	331	397	450	800
900	415	500	570	350	421	477	900
1,000	448	542	617	382	460	521	1,000

Correction factors

Ambient temp. (°C)	For ambient temperatures other than 30 °C (86 °F), multiply the ampacities shown above by the appropriate factor shown below.						Ambient temp. (°C)
21–25	1.08	1.05	1.04	1.08	1.05	1.04	70–77
26–30	1.00	1.00	1.00	1.00	1.00	1.00	79–86
31–35	0.91	0.94	0.96	0.91	0.94	0.96	88–95
36–40	0.82	0.88	0.91	0.82	0.88	0.91	97–104
41–45	0.71	0.82	0.87	0.71	0.82	0.87	106–113
46–50	0.58	0.75	0.82	0.58	0.75	0.82	115–122

*Unless otherwise specifically permitted elsewhere in this Code, the overcurrent protection for these conductor types shall not exceed 15 A for 14 AWG, 20 A for 12 AWG, and 30 A for 10 AWG copper; or 15 A for 12 AWG and 25 A for 10 AWG aluminum and copper-clad aluminum.
NATIONAL ELECTRICAL CODE, 2002 Edition.

Exothermic welding system

Additional tables

Table C1 maximum number of conductors or fixture wires in electrical metallic tubing (EMT) (based on table 1, chapter 9)

Conductors											
Type	Conductor size (AWG/kcmil)	Metric designator (trade size)									
		16 (½)	21 (¾)	27 (1)	35 (1¼)	41 (1½)	53 (2)	63 (2½)	78 (3)	91 (3½)	103 (4)
RHH,	14	4	7	11	20	27	46	80	120	157	201
RHW,	12	3	6	9	17	23	38	66	100	131	167
RHW-2	10	2	5	8	13	18	30	53	81	105	135
	8	1	2	4	7	9	16	28	42	55	70
	6	1	1	3	5	8	13	22	34	44	56
	4	1	1	2	4	6	10	17	26	34	44
	3	1	1	1	4	5	9	15	23	30	38
	2	1	1	1	3	4	7	13	20	26	33
	1	0	1	1	1	3	5	9	13	17	22
	1/0	0	1	1	1	2	4	7	11	15	19
	2/0	0	1	1	1	2	4	6	10	13	17
	3/0	0	0	1	1	1	3	5	8	11	14
	4/0	0	0	1	1	1	3	5	7	9	12
	250	0	0	0	1	1	1	3	5	7	9
	300	0	0	0	1	1	1	3	5	6	8
	350	0	0	0	1	1	1	3	4	6	7
	400	0	0	0	1	1	1	2	4	5	7
	500	0	0	0	0	1	1	2	3	4	6
	600	0	0	0	0	1	1	1	3	4	5
	700	0	0	0	0	0	1	1	2	3	4
	750	0	0	0	0	0	1	1	2	3	4
	800	0	0	0	0	0	1	1	2	3	4
	900	0	0	0	0	0	1	1	1	3	3
	1,000	0	0	0	0	0	1	1	1	2	3
TW,	14	8	15	25	43	58	96	168	254	332	424
THHW,	12	6	11	19	33	45	74	129	195	255	326
THW,	10	5	8	14	24	33	55	96	145	190	243
THW-2	8	2	5	8	13	18	30	53	81	105	135
RHH*,	14	6	10	6	28	39	64	112	169	221	282
RHW*,	12	4	8	13	23	31	51	90	136	177	227
RHW-2*	10	3	6	10	18	24	40	70	106	138	177
	8	1	4	6	10	14	24	42	63	83	106

* Types RHH, RHW, and RHW-2 without outer covering.

Conductors											
Type	Conductor size (AWG/kcmil)	Metric designator (trade size)									
		16 (½)	21 (¾)	27 (1)	35 (1¼)	41 (1½)	53 (2)	63 (2½)	78 (3)	91 (3½)	103 (4)
RHH,*	6	1	3	4	8	11	18	32	48	63	81
RHW,*	4	1	1	3	6	8	13	24	36	47	60
RHW-2*,	3	1	1	3	5	7	12	20	31	40	52
TW,	2	1	1	2	4	6	10	17	26	34	44
THHW,	1	1	1	1	3	4	7	12	18	24	31
THW,	1/0	0	1	1	2	3	6	10	16	20	26
THW-2	2/0	0	1	1	1	3	5	9	13	17	22
	3/0	0	1	1	1	2	4	7	11	15	19
	4/0	0	0	1	1	1	3	6	9	12	16
	250	0	0	1	1	1	3	5	7	10	13
	300	0	0	1	1	1	2	4	6	8	11
	350	0	0	0	1	1	1	4	6	7	10
	400	0	0	0	1	1	1	3	5	7	9
	500	0	0	0	1	1	1	3	4	6	7
	600	0	0	0	1	1	1	2	3	4	6
	700	0	0	0	0	1	1	1	3	4	5
	750	0	0	0	0	1	1	1	3	4	5
	800	0	0	0	0	1	1	1	3	3	5
	900	0	0	0	0	0	1	1	2	3	4
	1,000	0	0	0	0	0	1	1	2	3	4
THHN,	14	12	22	35	61	84	138	241	364	476	608
THWN,	12	9	16	26	45	61	101	176	266	347	443
THWN-2	10	5	10	16	28	38	63	111	167	219	279
	8	3	6	9	16	22	36	64	96	126	161
	6	2	4	7	12	16	26	46	69	91	116
	4	1	2	4	7	10	16	28	43	56	71
	3	1	1	3	6	8	13	24	36	47	60
	2	1	1	3	5	7	11	20	30	40	51
	1	1	1	1	4	5	8	15	22	29	37
	1/0	1	1	1	3	4	7	12	19	25	32
	2/0	0	1	1	2	3	6	10	16	20	26
	3/0	0	1	1	1	3	5	8	13	17	22
	4/0	0	1	1	1	2	4	7	11	14	18
	250	0	0	1	1	1	3	6	9	11	15
	300	0	0	1	1	1	3	5	7	10	13
	350	0	0	1	1	1	2	4	6	9	11
	400	0	0	0	1	1	1	4	6	8	10
	500	0	0	0	1	1	1	3	5	6	8
	600	0	0	0	1	1	1	2	4	5	7
	700	0	0	0	1	1	1	2	3	4	6
	750	0	0	0	0	1	1	1	3	4	5
	800	0	0	0	0	1	1	1	3	4	5
	900	0	0	0	0	1	1	1	3	3	4
	1,000	0	0	0	0	1	1	1	2	3	4

NATIONAL ELECTRICAL CODE, 2002 Edition
 * Types RHH, RHW, and RHW-2 without outer covering.

Exothermic welding system

Additional tables

Table C4 maximum number of conductors or fixture wires in intermediate metal conduit (IMC) (based on table 1, chapter 9)

Conductors											
Type	Conductor size (AWG/kcmil)	Metric designator (trade size)									
		16 (1/2)	21 (3/4)	27 (1)	35 (1 1/4)	41 (1 1/2)	53 (2)	63 (2 1/2)	78 (3)	91 (3 1/2)	103 (4)
RHH, RHW, RHW-2	14	4	8	13	22	30	49	70	108	144	186
	12	4	6	11	18	25	41	58	89	120	154
RHH, RHW, RHW-2	10	3	5	8	15	20	33	47	72	97	124
	8	1	3	4	8	10	17	24	38	50	65
	6	1	1	3	6	8	14	19	30	40	52
	4	1	1	3	5	6	11	15	23	31	41
	3	1	1	2	4	6	9	13	21	28	36
	2	1	1	1	3	5	8	11	18	24	31
	1	0	1	1	2	3	5	7	12	16	20
	1/0	0	1	1	1	3	4	6	10	14	18
	2/0	0	1	1	1	2	4	6	9	12	15
	3/0	0	0	1	1	1	3	5	7	10	13
	4/0	0	0	1	1	1	3	4	6	9	11
	250	0	0	1	1	1	1	3	5	6	8
	300	0	0	0	1	1	1	3	4	6	7
	350	0	0	0	1	1	1	2	4	5	7
	400	0	0	0	1	1	1	2	3	5	6
	500	0	0	0	1	1	1	1	3	4	5
	600	0	0	0	0	1	1	1	2	3	4
	700	0	0	0	0	1	1	1	2	3	4
	750	0	0	0	0	1	1	1	1	2	3
	800	0	0	0	0	0	1	1	1	2	3
	900	0	0	0	0	0	1	1	1	2	3
	1,000	0	0	0	0	0	1	1	1	2	3
	1,250	0	0	0	0	0	1	1	1	1	2
	1,500	0	0	0	0	0	0	1	1	1	1
	1,750	0	0	0	0	0	0	1	1	1	1
	2,000	0	0	0	0	0	0	1	1	1	1
TW, THHW, THW, THW-2	14	10	17	27	47	64	104	147	228	304	392
	12	7	13	21	36	49	80	113	175	234	301
	10	5	9	15	27	36	59	84	130	174	224
	8	3	5	8	15	20	33	47	72	97	124
RHH,* RHW,* RHW-2	14	6	11	18	31	42	69	98	151	202	261
RHH,* RHW,* RHW-2*	12	5	9	14	25	34	56	79	122	163	209
RHH,* RHW,* RHW-2*	10	4	7	11	19	26	43	61	95	127	163
RHH,* RHW,* RHW-2*	8	2	4	7	12	16	26	37	57	76	98
RHH,* RHW,* RHW-2*	6	1	3	5	9	12	20	28	43	58	75
RHH,* RHW,* RHW-2*	4	1	2	4	6	9	15	21	32	43	56

* Types RHH, RHW, and RHW-2 without outer covering.

Conductors											
Type	Conductor size (AWG/kcmil)	Metric designator (trade size)									
		16 (1/2)	21 (3/4)	27 (1)	35 (1 1/4)	41 (1 1/2)	53 (2)	63 (2 1/2)	78 (3)	91 (3 1/2)	103 (4)
TW, THHW, THW, THW-2	3	1	1	3	6	8	13	18	28	37	48
	2	1	1	3	5	6	11	15	23	31	41
	1	1	1	1	3	4	7	11	16	22	28
	1/0	1	1	1	3	4	6	9	14	19	24
	2/0	0	1	1	2	3	5	8	12	16	20
	3/0	0	1	1	1	3	4	6	10	13	17
	4/0	0	1	1	1	2	4	5	8	11	14
	250	0	0	1	1	1	3	4	7	9	12
	300	0	0	1	1	1	2	4	6	8	10
	350	0	0	1	1	1	2	3	5	7	9
	400	0	0	0	1	1	1	3	4	6	8
	500	0	0	0	1	1	1	2	4	5	7
	600	0	0	0	1	1	1	1	3	4	5
	700	0	0	0	0	1	1	1	3	4	5
	750	0	0	0	0	1	1	1	2	3	4
	800	0	0	0	0	1	1	1	2	3	4
	900	0	0	0	0	1	1	1	2	3	4
	1,000	0	0	0	0	0	1	1	1	3	3
THHN, THWN, THWN-2	14	14	24	39	68	91	149	211	326	436	562
	12	10	17	29	49	67	109	154	238	318	410
	10	6	11	18	31	42	68	97	150	200	258
	8	3	6	10	18	24	39	56	86	115	149
	6	2	4	7	13	17	28	40	62	83	107
	4	1	3	4	8	10	17	25	38	51	66
	3	1	2	4	6	9	15	21	32	43	56
	2	1	1	3	5	7	12	17	27	36	47
	1	1	1	2	4	5	9	13	20	27	35
	1/0	1	1	1	3	4	8	11	17	23	29
	2/0	1	1	1	3	4	6	9	14	19	24
	3/0	0	1	1	2	3	5	7	12	16	20
	4/0	0	1	1	1	2	4	6	9	13	17
	250	0	0	1	1	1	3	5	8	10	13
	300	0	0	1	1	1	3	4	7	9	12
	350	0	0	1	1	1	2	4	6	8	10
	400	0	0	1	1	1	2	3	5	7	9
	500	0	0	0	1	1	1	3	4	6	7
	600	0	0	0	1	1	1	2	3	5	6
	700	0	0	0	1	1	1	1	3	4	5
	750	0	0	0	1	1	1	1	3	4	5
	800	0	0	0	0	1	1	1	3	4	5
	900	0	0	0	0	1	1	1	2	3	4
	1,000	0	0	0	0	1	1	1	2	3	4

Note: This table is for concentric stranded conductors only. For compact stranded conductors, Table C4(A) should be used. *Types RHH, RHW, and RHW-2 without outer covering.

Exothermic welding system

Additional tables

Table C8 maximum number of conductors or fixture wires in rigid metal conduit (RMC) (based on table 1, chapter 9)

Conductors													
Type	Conductor Size (AWG/kcmil)	Metric designator (trade size)											
		16 (½)	21 (¾)	27 (1)	35 (1¼)	41 (1½)	53 (2)	63 (2½)	78 (3)	91 (3½)	103 (4)	129 (5)	155 (6)
RHH,	14	4	7	12	21	28	46	66	102	136	176	276	398
RHW,	12	3	6	10	17	23	38	55	85	113	146	229	330
RHW-2	10	3	5	8	14	19	31	44	68	91	118	185	267
	8	1	2	4	7	10	16	23	36	48	61	97	139
	6	1	1	3	6	8	13	18	29	38	49	77	112
	4	1	1	2	4	6	10	14	22	30	38	60	87
	3	1	1	2	4	5	9	12	19	26	34	53	76
	2	1	1	1	3	4	7	11	17	23	29	46	66
	1	0	1	1	1	3	5	7	11	15	19	30	44
	1/0	0	1	1	1	2	4	6	10	13	17	26	38
	2/0	0	1	1	1	2	4	5	8	11	14	23	33
	3/0	0	0	1	1	1	3	4	7	10	12	20	28
	4/0	0	0	1	1	1	3	4	6	8	11	17	24
	250	0	0	0	1	1	1	3	4	6	8	13	18
	300	0	0	0	1	1	1	2	4	5	7	11	16
	350	0	0	0	1	1	1	2	4	5	6	10	15
	400	0	0	0	1	1	1	1	3	4	6	9	13
	500	0	0	0	1	1	1	1	3	4	5	8	11
	600	0	0	0	0	1	1	1	2	3	4	6	9
	700	0	0	0	0	1	1	1	1	3	4	6	8
	750	0	0	0	0	0	1	1	1	3	3	5	8
	800	0	0	0	0	0	1	1	1	2	3	5	7
	900	0	0	0	0	0	1	1	1	2	3	5	7
	1,000	0	0	0	0	0	1	1	1	1	3	4	6
TW,	14	9	15	25	44	59	98	140	216	288	370	581	839
THHW,	12	7	12	19	33	45	75	107	165	221	284	446	644
THW,													
THW-2	10	5	9	14	25	34	56	80	123	164	212	332	480
	8	3	5	8	14	19	31	44	68	91	118	185	267
RHH,*	14	6	10	17	29	39	65	93	143	191	246	387	558
RHW,*													
RHW-2*													
RHH,*	12	5	8	13	23	32	52	75	115	154	198	311	448
RHW,*													
RHW-2*	10	3	6	10	18	25	41	58	90	120	154	242	350
RHH,*	8	1	4	6	11	15	24	35	54	72	92	145	209
RHW,*													
RHW-2*													

NATIONAL ELECTRICAL CODE, 2002 Edition

Exothermic welding system

Additional tables

Table C8 maximum number of conductors or fixture wires in rigid metal conduit (RMC) (based on table 1, chapter 9)

Conductors													
Type	Conductor Size (AWG/kcmil)	Metric designator (trade size)											
		16 (½)	21 (¾)	27 (1)	35 (1¼)	41 (1½)	53 (2)	63 (2½)	78 (3)	91 (3¾)	103 (4)	129 (5)	155 (6)
RHH,*	6	1	3	5	8	11	18	27	41	55	71	111	160
RHW,*	4	1	1	3	6	8	14	20	31	41	53	83	120
RHW-2*,	3	1	1	3	5	7	12	17	26	35	45	71	103
TW,	2	1	1	2	4	6	10	14	22	30	38	60	87
THHW,	1	1	1	1	3	4	7	10	15	21	27	42	61
THW,	1/0	0	1	1	2	3	6	8	13	18	23	36	52
THW-2	2/0	0	1	1	2	3	5	7	11	15	19	31	44
	3/0	0	1	1	1	2	4	6	9	13	16	26	37
	4/0	0	0	1	1	1	3	5	8	10	14	21	31
	250	0	0	1	1	1	3	4	6	8	11	17	25
	300	0	0	1	1	1	2	3	5	7	9	15	22
	350	0	0	0	1	1	1	3	5	6	8	13	19
	400	0	0	0	1	1	1	3	4	6	7	12	17
	500	0	0	0	1	1	1	2	3	5	6	10	14
	600	0	0	0	1	1	1	1	3	4	5	8	12
	700	0	0	0	0	1	1	1	2	3	4	7	10
	750	0	0	0	0	1	1	1	2	3	4	7	10
	800	0	0	0	0	1	1	1	2	3	4	6	9
	900	0	0	0	0	1	1	1	1	3	4	6	8
	1,000	0	0	0	0	0	1	1	1	2	3	5	8
THHN,	14	13	22	36	63	85	140	200	309	412	531	833	1,202
THWN,	12	9	16	26	46	62	102	146	225	301	387	608	877
THWN-2	10	6	10	17	29	39	64	92	142	189	244	383	552
	8	3	6	9	16	22	37	53	82	109	140	221	318
	6	2	4	7	12	16	27	38	59	79	101	159	230
	4	1	2	4	7	10	16	23	36	48	62	98	141
	3	1	1	3	6	8	14	20	31	41	53	83	120
	2	1	1	3	5	7	11	17	26	34	44	70	100
	1	1	1	1	4	5	8	12	19	25	33	51	74
	1/0	1	1	1	3	4	7	10	16	21	27	43	63
	2/0	0	1	1	2	3	6	8	13	18	23	36	52
	3/0	0	1	1	1	3	5	7	11	15	19	30	43
	4/0	0	1	1	1	2	4	6	9	12	16	25	36
	250	0	0	1	1	1	3	5	7	10	13	20	29
	300	0	0	1	1	1	3	4	6	8	11	17	25
	350	0	0	1	1	1	2	3	5	7	10	15	22
	400	0	0	1	1	1	2	3	5	7	8	13	20
	500	0	0	0	1	1	1	2	4	5	7	11	16
	600	0	0	0	1	1	1	1	3	4	6	9	13
	700	0	0	0	1	1	1	1	3	4	5	8	11
	750	0	0	0	0	1	1	1	3	4	5	7	11
	800	0	0	0	0	1	1	1	2	3	4	7	10
	900	0	0	0	0	1	1	1	2	3	4	6	9
	1,000	0	0	0	0	1	1	1	1	3	4	6	8

Note: This table is for concentric stranded conductors only.
 For compact stranded conductors, Table C8(A) should be used.
 *Types RHH, RHW, and RHW-2 without outer covering.