

D

EZGround®/Furseweld®/Blackburn® - Grounding systems



—
D

EZGround/Furseweld/Blackburn - Grounding systems

Table of contents

Section D

Overview	D7
Signal reference grid connectors	D8
Clamps	D9
Service post connectors	D21
Transformer tank ground connectors	D23
Conduit hubs	D24
Lay-in lug connectors	D25
Ground plates	D27
EZGround compression grounding connectors	D29
Ground rods	D44
Flexible braids	D48
Exothermic welding system	D49
Competitive cross reference	D113

Overview

Compression method grounding connectors save 50–75% in time and labor costs

01 This installation method results in a long-lasting low-installed cost connection. You can install it and forget it. Before compression, typical cable connector cross section of cable and connector consists of about 75% metal and 25% air. After ABB method compression, the cross section shows 100% metal with virtually no air spaces.

- Eliminates exothermic welding
- Reduces time and labor costs
- Minimizes possibility of poor connections

ABB introduces a method of compression to replace exothermic welding and its associated disadvantages. This compression method is designed to provide quick, reliable connections for grid grounding at significantly lower installed costs because compression connectors install in less time, in any weather, and are unaffected by moisture, reducing downtime. In addition, our compression connectors for grid grounding require no special training for installation. They are made of high-conductivity wrought and cast copper, and are used for connecting and tapping cross grid, loop lines and ground rods for direct burial or concrete embedded ground grid systems. The ABB compression system uses standard electrical connector installation tools.

Meets all applicable specifications

ABB grid and ground rod connectors satisfy the requirements of CEC Section 10 for connecting to the grounding electrode system. They also meet the requirements of UL and CSA standards being acceptable as grounding and bonding equipment suitable for direct burial. ABB grid and ground rod connectors also satisfy the recommended practice for the selection of grounding connector joints described in the IEEE 837 standard for qualifying permanent connections used in substation grounding.

The connectors conform to the following IEEE 837 standard requirements:

- 350 °C current cycling
- Freeze-thaw test
- Accelerated aging – nitric acid/salt spray
- Mechanical, tensile and electromagnetic force (EMF) criteria
- Install in any weather – cut downtime
- Enhance safety
- Easy to install – no special training



Overview

Reliable installations through compression connections

- 01 TBM14M
(Suggested tool for EZGround connectors to ground rods up to 5/8 in. diameter.)
- 02 Before compression
- 03 After compression



02



03



01

Dies that are used in hand and hydraulic tools contain the die code numbers, which are engraved on the compression surface of the die. Under compression, this number becomes embossed on the completed connection for inspection purposes.

The inspector compares the die code number embossed on the connector with the die table to ensure that the proper connector was compressed with the correct die for that particular size conductor.

This installation method results in a long-lasting, low-installed cost connection. You can install it and forget it. Before compression, typical cable connector cross section of cable and connector consists of about 75% metal and 25% air. After ABB method compression, the cross section shows 100% metal with virtually no air spaces.



Overview

ABB offers a complete line of grid-ground compression connectors. Our EZGround connectors are designed for direct burial and offer a safe, efficient alternative to exothermic welding products. Grid-ground installations do not require explosive charges, and can be installed in various climate conditions.

These range-taking products will reduce the number of connectors and dies needed for your installation.

EZGround products meet all applicable standards (IEEE 837, UL, CSA). Connectors are prefilled with oxide inhibitors and sealed.

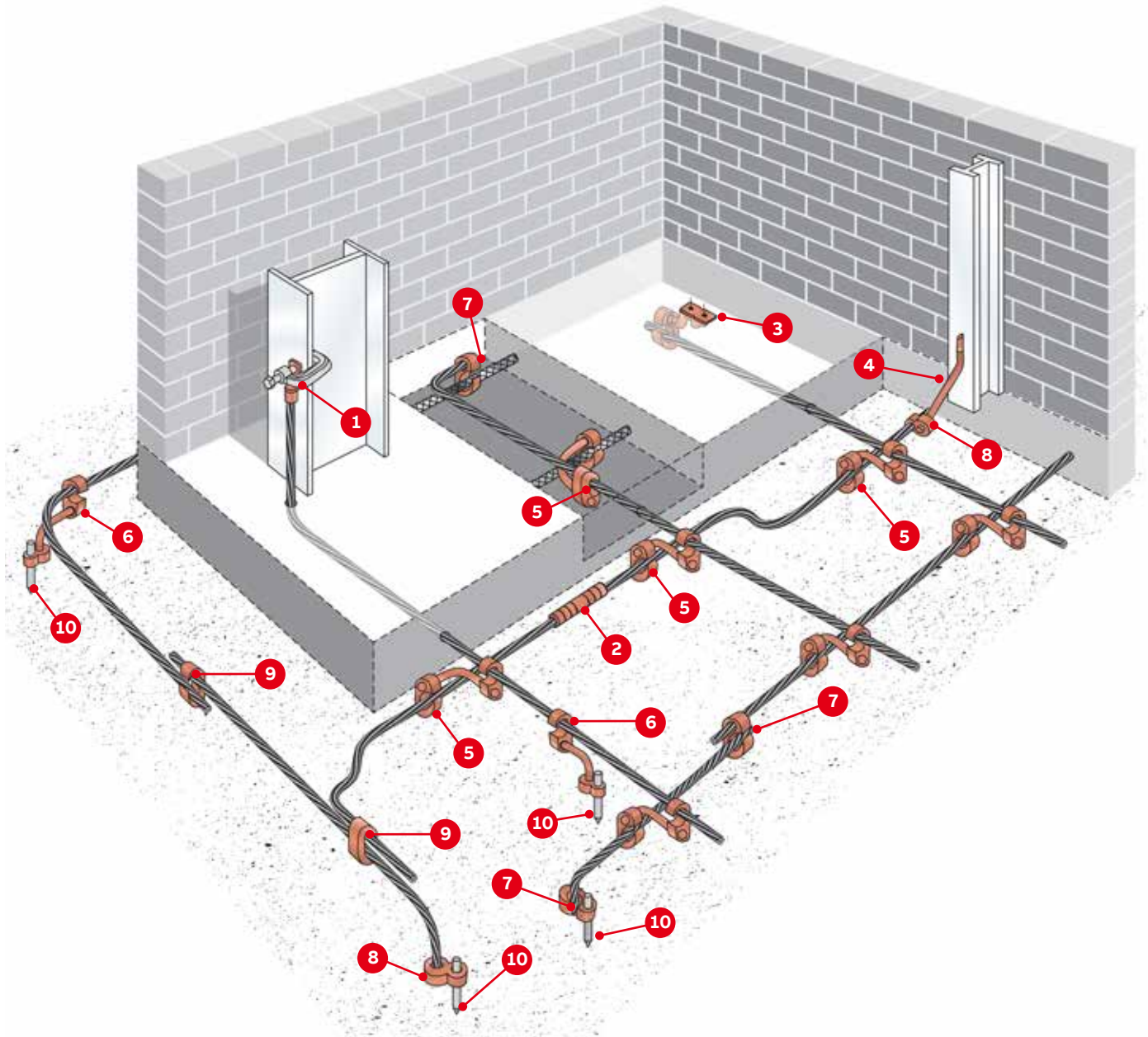

Overview



1 I-beam ground clamp connectors



2* Two-way splice connectors



3 Ground plates



4 Structural grounding studs



5 Figure 6 to 6 compression grid and ground rod connectors

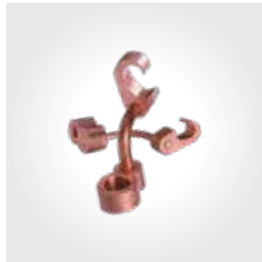

6 Figure 6 to 8 compression ground rod to grid connectors



7 Figure 6 compression ground tap connectors



8 Figure 8 compression ground rod tap connectors



9 C-tap grid tap connectors



10 Galvanized steel ground rods (stainless steel rods are also available)
Copper bonded steel ground rods
Copper bonded steel sectional ground rods



* Color-Keyed® two-way splice connectors

Signal reference grid connectors



Compress #8 AWG through 4/0 AWG cable

- Clamp onto pedestal posts up to 1 in. diameter square and 1¼ in. round
- Can be used as “X” or “T” configuration cable to post
- High-conductivity wrought-copper construction



Cat. no.	Conductor range (AWG)	Die cat no.	Installing tools and die codes TBM14M and TBM15I		Colour code
			Die code		
SRG8-4	#8	15527SS	29		Grey
	#6 to #4	15528SS	33		Brown
SRG2-1	#2 and #1	15508SS	42		Pink
SRG10-20	1/0 and 2/0	15530SS	50		Orange
SRG30-40	3/0 and 4/0	15511SS	54		Purple



Secure signal reference grid wires to raised-floor support posts

- Range-taking design accepts #4 to #8 AWG grid wire and fits ¾ in. square to 1 in. round
- Lay-in feature means no kinks or bends
- Quick, easy installation
- Only one screw to tighten
- Enable grid wire to make direct, low-resistance contact with support posts
- Stamped-steel construction, zinc plated



Cat. no.	Description	Wire range (AWG)
3900 (Unit)	¾ in. square to 1 in. round	#8-#4
3900BP (Bulk pack)	¾ in. square to 1 in. round	#8-#4



Clamps

Waterpipe ground clamps



Cat. no.	Ground wire size (AWG)	Water pipe size (in.)
2-TB	#6, #4, #2	½, ¾, 1 or rebar 410
3-TB	#6, #4, #2	1¼, 1½ or 2
4-TB	#6, #4, #2	2½, 3 or 3½
5-TB	#6, #4, #2	4, 4½ or 5
6-TB	#6, #4, #2	6



Malleable iron crossbar, steel U-bolt complete with copper cable clamp with serrations.

Waterpipe ground clamps



Cat. no.	Ground wire size (AWG)	Water pipe size (in.)
3902BU*	#4-4/0	½-1
3903BU*	#4-4/0	1¼-2
3904BU*	#4-4/0	2½-3½
3905BU*	#4-4/0	4-5
3906BU*	#4-4/0	6
3907BU*	#4-4/0	8
3908BU*	#4-4/0	10
3909BU*	#4-4/0	12



Material: Bronze U-bolt and nut complete with bronzed aluminum cap and crossbar with a bright dip finish. *UL listed for direct burial.

Waterpipe ground clamps



Cat. no.	Ground wire size (AWG)	Water pipe size (in.)
3902-TB	#4-4/0	½-1
3903	#4-4/0	1¼-2
3904	#4-4/0	2½-3½
3905-TB	#4-4/0	4-5
3906-TB	#4-4/0	6
3907	#4-4/0	8
3908	#4-4/0	10
3909-TB	#4-4/0	12



Material: Steel U-bolt and nut complete with bronzed aluminum cap and crossbar cadmium plated plus gold chromate finish.

Ground clamps



Cat. no.	Material	Water pipe, copper tubing size (in.)	Ground rod size (in.)
3826*	Malleable iron	½, ¾	½-1
3846*	Bronze	½, ¾	½-1
3840-TB*	Malleable iron	½, ¾ or 1	½-1



* For unarmored copper wires #6, #4 AWG. UL approved for direct burial.
 • #8 thru #4 AWG. Not CSA certified

Ground clamps for K&L grade copper tubing only



Cat. no.	Ground wire size (AWG)	Water pipe, copper tubing size (in.)
3844*	#8-#4	½-1
3888**	#8-#4	½-1, also rebar 4-10

For armored and unarmored wires



* With steel screws.
 ** UL approved for direct burial. Silicon bronze screws.

Ground clamp accessories



Cat. no.	Description	For use with
10102-TB	For 1¼ to 1½ in. cables	#8-#2 AWG ground wire



Material: Malleable iron, zinc plated.



Cat. no.	For use with
10105	Single conductors #4 AWG solid to 2/0 AWG str.
10109	Single conductors 2/0 AWG solid to 4/0 AWG str.



Clamps



Type JAB — ground rod clamps

- Cast of high-strength corrosion-resistant copper alloy
- Both hex head and socket set screws available

- Long bearing surface of clamp on ground wire secures ground connection
- Listed for direct burial



Dimensions (in.)

Cat. no.	Socket set screw	Hex head Bolt	Nominal rod dia.		Wire range		A (max.) socket screw	A (max.) hex bolt	Screw thread size UNC-2A	B	C	D		
			(in.)	(mm)	Max. (AWG)	Min. (AWG)							Max. (mm ²)	Min. (mm ²)
JAB12*		JAB12H	1/2	12.7	2 str.	10 sol.	33.6	5.2	1 ¹⁹ / ₃₂	2 ³ / ₃₂	7/16-14	2 ⁷ / ₃₂	7/8	1 ⁹ / ₃₂
JAB58		JAB58H	5/8	15.8	1/0 str.	8 sol.	53.4	8.3	1 ²⁷ / ₃₂	2 ¹³ / ₆₄	7/16-14	2 ⁹ / ₃₂	1	1 ¹ / ₁₆
JAB34		JAB34H	3/4	19.0	1/0 str.	8 sol.	53.4	8.3	2	2 ¹¹ / ₃₂	7/16-14	1 ¹ / ₁₆	1	5 ¹ / ₆₄
-		JAB34C	3/4 + 5/8	15.8 to 19.0	3/0 str.	8 sol.	95.0	8.3	-	2 ¹¹ / ₃₂	7/16-14	1 ¹ / ₈	1 ¹ / ₃₂	1 ³ / ₁₆
JAB1		JAB1H	1	25.0	3/0 str.	8 sol.	107.1	8.3	2 ¹ / ₄	3	7/16-14	1 ¹¹ / ₃₂	1 ¹ / ₁₆	1

Diagrams

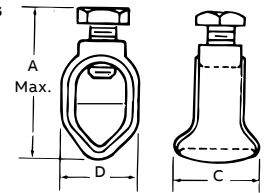

* CSA not applicable.
Add suffix P to cat. no. for tin-plated clamp.



Type G — budget line ground clamps

- A dependable ground connection offered at a substantial saving
- Cast of high-strength corrosion-resistant copper alloy

- Hex head bolts
- Simplified compact design will make a lasting, trouble-free connection
- Listed for direct burial



Dimensions (in.)

Cat. no.	Nominal rod dia.		Wire range		A (Max.) Bolt	Screw Thread Size UNC-2A	B	C	D	E		
	(in.)	(mm)	Max. (AWG)	Min. (AWG)							Max. (mm ²)	Min. (mm ²)
G3-TB*	3/8	9.5	4 str.	10 sol.	21.1	5.2	1-3/8	5/16-18	1 ¹ / ₁₆	1/2	2 ⁷ / ₆₄	3/8
G4	1/2	12.7	2 str.	10 sol.	33.6	5.2	-	3/8-16	2 ⁷ / ₃₂	3/8	3 ⁷ / ₆₄	1/2
G5	5/8	15.8	2 str.	10 sol.	33.6	5.2	-	3/8-16	2 ⁹ / ₃₂	3/8	4 ³ / ₆₄	1/2
G6	3/4	19.0	2 str.	10 sol.	33.6	5.2	-	3/8-16	1 ¹ / ₁₆	3/8	1 ³ / ₁₆	1/2

Diagrams

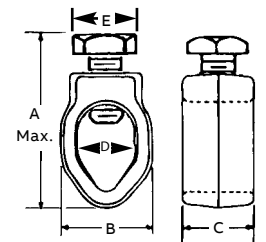

* Not UL listed and CSA not applicable.
Add suffix P to cat. no. for tin-plated clamp.

Clamps



Budget price cast bronze clamp

Similar to aluminum water pipe clamp but lighter in construction.



Cat. no.	Water pipe size (in.)	Conductor range (AWG)		Dimensions (in.)		
		Max.	Min.	A	B	C
JJR	½ to 1	#4 str.	#10 sol.	1 ¹⁹ / ₃₂	2 ⁷ / ₃₂	7/ ₈

Diagrams

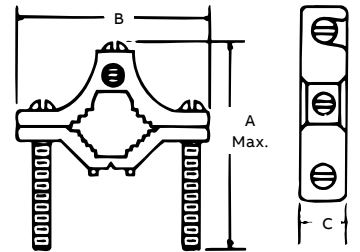

Add suffix C to cat. no. to specify plating.

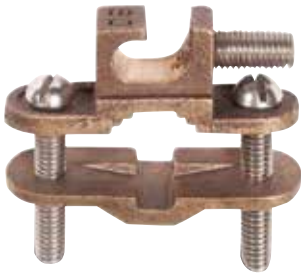

Type JDLI — direct burial ground clamp

Lay-in feature reduces installation time for difficult bends or continuous loops of ground wire.

- UL listed for direct burial in earth/concrete
- UL listed for connection to ground rod, pipe or rebar up to 1 in.
- Constructed from bronze alloy and high-performance stainless steel bolts
- Designed for easy installation of difficult bends or continuous loops



Cat. no.	Pipe size (in.)	Rebar size (in.)	Ground rod size (in.)	Conductor range (AWG)	Mech. conn./splice (UL Listed)
JDLI	½-1	¾-1	¼-1	#10 sol.-#2 str.	(2) #8 AWG sol.

Clamps



Type JWR — wide-range ground rod clamp

- Listed for direct burial in earth/concrete
- Constructed from bronze alloy and high-performance stainless steel bolt
- Provides wide range of connection sizes
- More than 300 lb torque capacity



Cat. no.	Nominal rod dia.		Wire range				Dimensions (in.)			
	(in.)	(mm)	Max. (AWG)	Min. (AWG)	Max. (mm ²)	Min. (mm ²)	A (max.) bolt	B	C	D
JWR	3/8*	9.5	1/0 str.	10 sol.	53.4	5.2	1.535	1.050	0.812	0.652
	1/2	12.7	1/0 str.	10 sol.	53.4	5.2	1.535	1.050	0.812	0.652
	5/8	15.8	1/0 str.	10 sol.	53.4	5.2	1.535	1.050	0.812	0.652
	3/4	19.0	1/0 str.	10 sol.	53.4	8.3	1.535	1.050	0.812	0.652

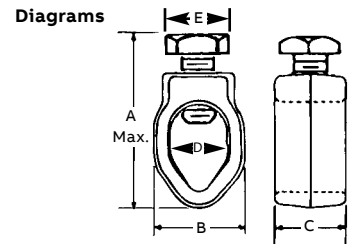

* 3/8 in. rod CSA not applicable/listed by UL.



Types GG and GGH — heavy-duty ground rod clamps

- Cast of high-strength corrosion-resistant copper alloy; two types of screws available
- Type GG has a socket set screw
- Type GGH has a hex head bolt
- Floating pressure bar distributes pressure evenly over a large area of the ground wire
- Axial groove keeps wire and rod in perfect alignment



Cat. no.		Nominal rod dia.		Wire range				A (max.)		Screw thread size UNC-2A			Dimensions (in.)	
		(in.)	(mm)	Max. (AWG)	Min. (AWG)	Max. (mm ²)	Min. (mm ²)	socket screw	hex bolt		B	C		
GG12	GG12H	1/2	12.7	2 str.	8 sol.	33.6	8.3	1 ¹³ / ₆₄	1 ¹³ / ₁₆	7/16-14	27/32	15/16		
GG58	GG58H	5/8	15.8	2/0 str.	8 sol.	53.6	8.3	1 ⁵¹ / ₆₄	2 ⁷ / ₃₂	7/16-14	61/64	15/16		
-	GG34H**	3/4	19.0	4/0 str.	8 sol.	120.6	8.3	-	3	1/2-14	1 3/8	1 1/4		

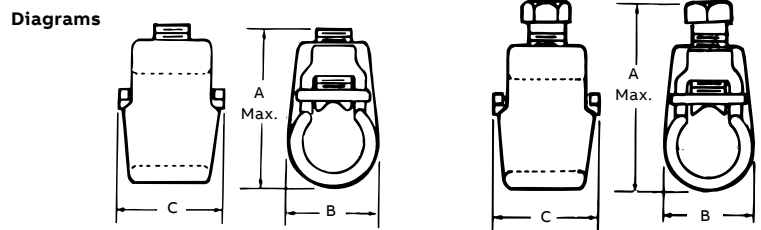

** CSA not applicable.
GG34H has no pressure bar or axial groove.
Add suffix P to cat. no. for tin-plated clamp.

Clamps



Budget price cast bronze clamps

- Type swings 360° for ease of alignment.
- Pipe clamping portion identical to “JA” clamp
- Pressure-bar type conduit hub adjusts to fit ½ in. or ¾ in. EMT or ½ in. rigid conduit
- Brass washer provides positive contact with grounding conductor
- Furnished with zinc-plated screws

Cat. no.	Conduit size	Water pipe size (in.)	Conductor range (AWG)	
			Max.	Min.
JPT	½ in. or ¾ in. EMT, ½ in. rigid	½ to 1	#6 sol.	#10 sol.
JPT2	½ in. or ¾ in. EMT, ½ in. rigid	1¼ to 2	#6 sol.	#10 sol.
JPT4	½ in. or ¾ in. EMT, ½ in. rigid	2½ to 4	#6 sol.	#10 sol.



Cast bronze clamps

- For connecting armored cable to water pipe.
- Clamping portion similar to standard “J” clamp
- Special pressure bar grips armor or outer cable insulation to reduce chance of grounding conductor being pulled out
- Furnished with zinc-plated screws



Cat. no.	Water pipe size (in.)	Conductor range (AWG)		Dimensions (in.)					
		Max.	Min.	A	B	C	D	E	G
JA	½ to 1	#6 sol.	#10 sol.	2¾	2 ¹¹ / ₃₂	2 ⁵ / ₃₂	2 ⁹ / ₃₂	1 ⁵ / ₃₂	1 ³ / ₈
JA2	1¼ to 2	#6 sol.	#10 sol.	3¾	3½	1 ³ / ₁₆	2 ⁹ / ₃₂	1 ⁵ / ₃₂	1 ³ / ₈
JA2124	2½ to 4	#6 sol.	#10 sol.	6	6 ⁵ / ₁₆	1	2 ⁹ / ₃₂	1 ⁵ / ₃₂	1 ³ / ₈

Diagrams

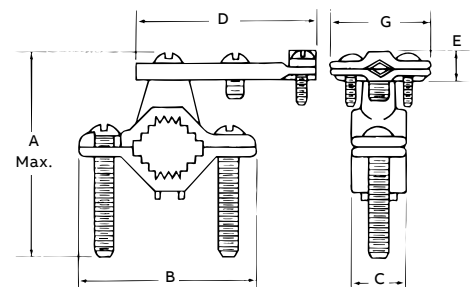

Add suffix C to cat. no. to specify plating.

Clamps



Cast bronze clamps for conduit

- For grounding rigid conduit systems
- Continuity from rigid conduit system to ground provided by cast bronze threaded conduit hub
- Hub swings 360° for easy alignment
- Heavy brass washer protects clamped grounding conductor
- Furnished with zinc-plated screws
- Cast bronze pipe clamping portion identical to that used in “JA” clamp



Cat. no.	Conduit size (in.)	Water pipe size (in.)	Conductor range (AWG)		Dimensions (in.)					
			Max.	Min.	A	B	C	D	E	G
JP12	½	½ to 1	#6 sol.	#10 sol.	2¾	2 ¹¹ / ₃₂	2 ³ / ₃₂	1 ⁹ / ₆₄	1	2½
JP212	½	1¼ to 2	#6 sol.	#10 sol.	3¾	3½	1 ³ / ₁₆	1 ⁹ / ₆₄	1	2½
JP212412	½	2½ to 4	#6 sol.	#10 sol.	6	6 ⁵ / ₁₆	1	1 ⁹ / ₆₄	1	2½
JP34	¾	½ to 1	#2/0 str.	#10 sol.	2¾	2 ¹¹ / ₃₂	2 ³ / ₃₂	2 ⁵ / ₁₆	1¼	2 ³ / ₁₆
JP234	¾	1¼ to 2	#2/0 str.	#10 sol.	3¾	3½	1 ³ / ₁₆	2 ⁵ / ₁₆	1¼	2 ³ / ₁₆
JP1	1	½ to 1	#3/0 str.	#10 sol.	2¾	2 ¹¹ / ₃₂	2 ³ / ₃₂	2 ⁵ / ₁₆	1½	2 ³ / ₈
JP21	1	1¼ to 2	#3/0 str.	#10 sol.	3¾	3½	1 ³ / ₁₆	2 ⁵ / ₁₆	1½	2 ³ / ₈
JP21241	1	2½ to 4	#3/0 str.	#10 sol.	6	6 ⁵ / ₁₆	1	2 ⁵ / ₁₆	1½	2 ³ / ₈

Diagrams

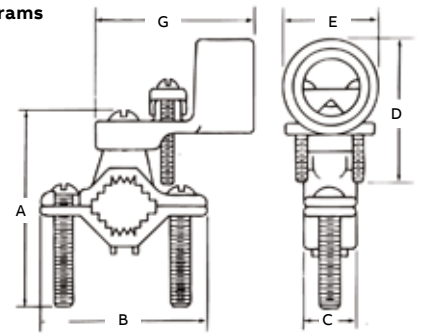

Add suffix C to cat. no. to specify plating.



Cast bronze clamps with copper strap

- Flexible copper strap makes alignment easy
- For grounding rigid conduit systems
- Same features as “JP” clamp plus flexible copper strap
- Strap helps protect conduit system from water system vibrations
- Furnished with zinc-plated screws

Cat. no.	Conduit size (in.)	Water pipe size (in.)	Conductor range (AWG)	
			Max.	Min.
JPS12	½	½ to 1	#6 sol.	#10 sol.
JPS34	¾	½ to 1	2/0 str.	#10 sol.
JPS1	1	½ to 1	3/0 str.	#10 sol.

Add suffix C to cat. no. to specify plating.

Clamps



Cast bronze ground clamps

- Connect copper ground wire to water pipe, copper tubing or ground rods
- High-strength, high-conductivity copper alloy (over 80% copper)
- UL approved for direct burial



Cat. no.	Water pipe size (in.)	Conductor range
JD	½ to 1	#2 str.–#10 str.
J2D	1¼ to 2	#2 str.–#10 str.



Type J – cast bronze ground clamps

- For connecting grounding conductor to water pipe or copper tube
- Cast of high-strength, highly conductive copper alloy
- Screws plated for corrosion resistance
- UL listed

Cat. no.	Water pipe size (in.)	Conductor range (AWG)		Dimensions (in.)		
		Max.	Min.	A	B	C
J	½ to 1	#2 str.	#10 sol.	2¾	2 ¹¹ / ₃₂	2 ³ / ₃₂
J2BB	1¼ to 2	#2 str.	#10 sol.	3¾	3½	1 ³ / ₁₆
J2124	2½ to 4	#2 str.	#10 sol.	6	6 ⁵ / ₁₆	1
J6	4¼ to 6	#2 str.	#10 sol.	7¾	8 ¹ / ₈	1

Diagrams

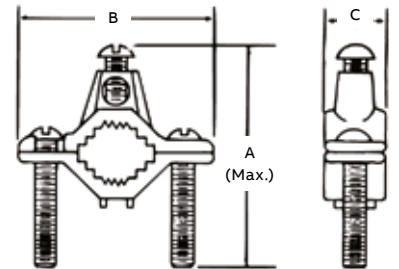

Clamps



Type GUV – U-bolt clamps

- Listed for direct burial in earth or concrete
- For connecting copper or copper-clad steel grounding conductor to ground rod, pipe or rebar
- Excellent for connecting multiple electrodes with a single cable as in substation grounding
- GUV body components are cast or forged from copper alloy and U-bolts are stainless steel
- Specially designed spacer provides proper alignment between cable and electrode and affords more positive contact area



Cat. no.	Conductor range Cu (AWG)		Nominal rod size (in.)		IPS pipe size (in.)		Dimensions (in.)		
	Max.	Min.	Max.	Min.	Max.	Min.	A	B	C
GUV584	#4	#8	3/4	5/8	3/8	–	2 ¹³ / ₁₆	1 ⁹ / ₁₆	2 ¹ / ₄
GUV5821	2/0	#4	3/4	5/8	3/8	–	2 ¹³ / ₁₆	1 ⁹ / ₁₆	2 ¹ / ₄
GUV5825	250	2/0	3/4	5/8	3/8	–	2 ¹³ / ₁₆	1 ⁹ / ₁₆	2 ¹ / ₄
GUV784	#4	#8	1	7/8	3/4	1/2	2 ³ / ₄	1 ⁹ / ₁₆	2 ⁵ / ₈
GUV7821	2/0	#4	1	7/8	3/4	1/2	2 ³ / ₄	1 ⁹ / ₁₆	2 ⁵ / ₈
GUV7825	250	2/0	1	7/8	3/4	1/2	2 ³ / ₄	1 ⁹ / ₁₆	2 ⁵ / ₈
GUV1184	#4	#8	1 ¹ / ₄	1 ¹ / ₈	1	–	3 ⁵ / ₁₆	1 ⁹ / ₁₆	2 ³ / ₄
GUV11821	2/0	#4	1 ¹ / ₄	1 ¹ / ₈	1	–	3 ⁵ / ₁₆	1 ⁹ / ₁₆	2 ³ / ₄
GUV1384	#4	#8	1 ¹ / ₂	1 ³ / ₈	1 ¹ / ₄	–	3 ⁷ / ₁₆	1 ⁹ / ₁₆	2 ¹⁵ / ₁₆
GUV13821	2/0	#4	1 ¹ / ₂	1 ³ / ₈	1 ¹ / ₄	–	3 ⁷ / ₁₆	1 ⁹ / ₁₆	2 ¹⁵ / ₁₆
GUV13825	250	2/0	1 ¹ / ₂	1 ³ / ₈	1 ¹ / ₄	–	3 ⁷ / ₁₆	1 ⁹ / ₁₆	2 ¹⁵ / ₁₆
GUV1584	#4	#8	1 ⁷ / ₈	1 ⁵ / ₈	1 ¹ / ₂	–	3 ¹⁵ / ₁₆	1 ⁹ / ₁₆	3 ³ / ₁₆
GUV15821	2/0	#4	1 ⁷ / ₈	1 ⁵ / ₈	1 ¹ / ₂	–	3 ¹⁵ / ₁₆	1 ⁹ / ₁₆	3 ³ / ₁₆
GUV15825	250	2/0	1 ⁷ / ₈	1 ⁵ / ₈	1 ¹ / ₂	–	3 ¹⁵ / ₁₆	1 ⁹ / ₁₆	3 ³ / ₁₆
GUV204	#4	#8	2 ³ / ₈	2	2	–	4 ⁷ / ₁₆	1 ⁹ / ₁₆	3 ¹¹ / ₁₆
GUV2021	2/0	#4	2 ³ / ₈	2	2	–	4 ⁷ / ₁₆	1 ⁹ / ₁₆	3 ¹¹ / ₁₆
GUV2025	250	2/0	2 ³ / ₈	2	2	–	4 ⁷ / ₁₆	1 ⁹ / ₁₆	3 ¹¹ / ₁₆
GUV21221	2/0	#4	2 ⁷ / ₈	2 ¹ / ₂	2 ¹ / ₂	–	4 ¹⁵ / ₁₆	1 ⁹ / ₁₆	4 ³ / ₁₆
GUV21225	250	2/0	2 ⁷ / ₈	2 ¹ / ₂	2 ¹ / ₂	–	4 ¹⁵ / ₁₆	1 ⁹ / ₁₆	4 ³ / ₁₆
GUV3021	2/0	#4	3 ¹ / ₂	3	3	–	5 ⁹ / ₁₆	1 ⁹ / ₁₆	4 ¹³ / ₁₆
GUV3025	250	2/0	3 ¹ / ₂	3	3	–	5 ⁹ / ₁₆	1 ⁹ / ₁₆	4 ¹³ / ₁₆
GUV31221	2/0	#4	4	3 ¹ / ₂	3 ¹ / ₂	–	6 ¹ / ₁₆	1 ⁹ / ₁₆	5 ¹ / ₂
GUV4021	2/0	#4	4 ¹ / ₂	4	4	–	6 ⁵ / ₁₆	1 ⁹ / ₁₆	5 ¹¹ / ₁₆
GUV4025	250	2/0	4 ¹ / ₂	4	4	–	6 ⁵ / ₁₆	1 ⁹ / ₁₆	4 ¹³ / ₁₆

Diagrams

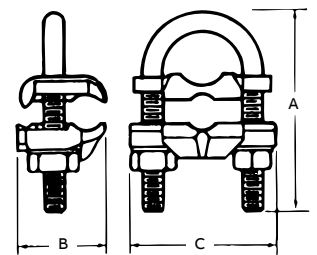

For tin-plated, add suffix TP to cat. no.

Clamps

Technical specifications

- 01 CI3106
- 02 CI3108
- 03 CI3110U
- 04 CI3112U
- 05 CIGRC58



01



02



03



04



05



Cat. no.	Water pipe size (in.)	Ground wire size (AWG)		Ground rod size (in.)	
		Min.	Max.	Galv. steel	Copper clad
Ground clamps (zinc alloy body/steel screws)					
CI3106	½ to 1	#10 sol.	#2 str.	⅝ to 1*	—
Ground clamps (zinc/steel)					
CI3108	½ to 1	#10 sol.	#2 str.	⅝ to 1*	—
For connecting grounding conductor to either galvanized steel rod or water pipe.					
Ground clamps (brass body/brass screws)					
CI3110U	½ to 1	#10 sol.	#2 str.	⅝ to 1*	⅝ to 1
For connecting grounding conductor to either galvanized steel rod, copper clad or water pipe. CSA approved for wet locations and for direct burial.					
Ground clamps (brass body/brass screws)					
CI3112U	1¼ to 2	#10 sol.	#2 str.	—	—
For connecting grounding conductor to water pipe. CSA approved for wet locations and for direct burial.					
Ground rod clamps (bronze body/brass screws)					
CIGRC58	—	#10 sol.	#2 str.	⅝	⅝
CIGRC34	—	#8 sol.	1/0 str.	¾	¾

For connecting grounding conductor to either galvanized steel rod or copper clad rod.
CSA approved for wet locations and for direct burial.

*Reversible.

Clamps



Type GTC – Tower ground clamps

- Bolt has square shank to prevent turning and allow clamp to be tightened with one wrench
- GTC 23 and 24 are two-piece clamps for connecting ground lead cable to flat metal surface; ideal for grounding substations on tower footings

- Castings are of high-strength, corrosion-resistant copper alloy
- GTC 13 and 14 are economical one-piece clamps that perform the same function as two-piece clamps except the under-pad support is omitted and conductor is connected directly to tower
- Add suffix L to cat. no. for ½ in. channel thickness



Cat. no.	Conductor range				Channel thickness (in.)	Dimensions (in.)						
	Max. (AWG)	Min. (AWG)	Max. (mm ²)	Min. (mm ²)		A	B	D	E	G	H	R
GTC13	2/0 str.	#4 sol.	67.4	21.1	¼	1 ¹⁵ / ₃₂	–	¼ ₁₆	1 ²¹ / ₃₂	1 ¹³ / ₃₂	¾	7 ¹ / ₃₂
GTC14	250 kcmil	2/0 str.	126.6	67.4	¼	1 ¹⁵ / ₁₆	–	¾	1 ¹⁵ / ₁₆	1 ¹³ / ₃₂	½	5 ¹ / ₁₆
GTC23	2/0 str.	#4 sol.	67.4	21.1	¼	1 ⁴¹ / ₆₄	7 ¹ / ₁₆	¼ ₁₆	2 ²¹ / ₃₂	1 ³ / ₃₂	¾	–
GTC24	250 kcmil	2/0 str.	126.6	21.1	¼	1 ⁶¹ / ₆₄	5 ¹ / ₈	¾	1 ¹⁵ / ₁₆	1 ³ / ₈	½	–

Diagrams

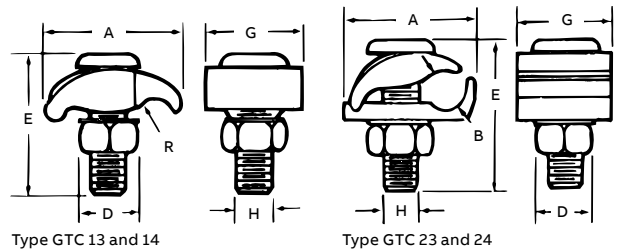

CTG250 – Wide range tower ground clamp

- For use with aluminum or copper conductors and in aluminum or galvanized steel cable tray
- Ribbed neck on the bolt prevents rotation during tightening if 0.440 in. dia. hole is used



Cat. no.	Wire range (2 sides) (AWG or kcmil)	Height (in.)	Width (in.)	Depth (in.)	Nut (flats) (in.)
CTG250	#2 sol. (0.258 in. Dia.), 250 (0.575 in. Dia.)	1.95	2.00	1.13	0.560

Diagram

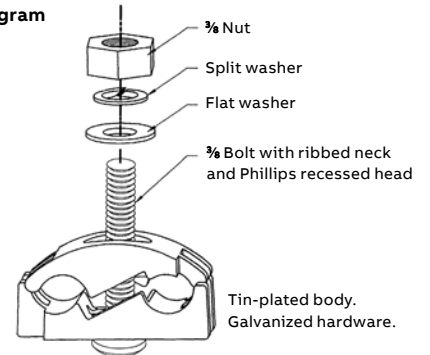

Clamps



I-beam ground clamps

Connect ground cable to I-beam or any 1 in. maximum structural steel member – without welding or drilling.

- Breakaway bolt head shears at predetermined torque to ensure tight connection
- Heavy-duty compression lug provides excellent current-carrying capabilities
- Surface of steel must be cleaned in accordance with installation instruction sheet provided with product
- Connector made of high-conductivity cast copper bright dip
- Clamp made of drop-forged high-grade steel, zinc-plated



Cat. no.	Wire range (AWG or kcmil)	TBM15I, TBM15 Installing tool, die code	Die cat. no.	Number of crimps
IBG2-10	#2-1/0	66H	15534SS	2
IBG20-40	2/0-4/0	76H	15512SS	2
IBG350-500	350-500	115H	15504SS	2

Hydraulic tooling with hex crimp dies.
Use 15500TB adaptor for TBM15I 15-ton tool.



Ground clamps

For permanent, reliable connection.

- Crimp to cable
- Clamp to ground rod and rebar
- Use standard Color-Keyed hand and hydraulic tools
- Colour-coded for easy installation die selection
- Made from high-conductivity wrought copper
- Furnished with stainless steel hardware, ¼ in. washers, bolts and nuts



Cat. no.	Wire size (AWG)	Ground rod diameter (in.)	Rebar (in.)	Bolt size (in.)	Die code and colour
CC2C-45R	#2-#3	½ or ⅝	0.80	0.25	33 Brown
CC1C-45R	#1	½ or ⅝	0.80	0.25	37 Green
CC10C-56R	1/0	⅝ or ¾	0.83	0.38	42 Pink
CC20C-56R	2/0	⅝ or ¾	0.83	0.38	45 Black
CC40C-56R	4/0	⅝ or ¾	0.83	0.38	54 Purple

UL Approved for direct burial.

Clamps



Flat-surface ground clamps

Terminate or connect continuous runs of copper cable to flat surfaces.

- Captive “keeper bar” design extends cable range and helps hold cable prior to crimping, facilitating installation
- Saddles marked with conductor size and die code
- Conductor can be assembled to saddle with standard dies and hydraulic tools
- Made from high-conductivity cast copper



Cat. no.	Wire range (AWG or kcmil)	Bolt hole (in.)	Die code no.	Qty.	Std. pkg.	Wt. per 100	Hex die		Dimensions in. (mm)				
							Cat. no.	Die code no.	L1	L2	D	C	H
53055FL	1/0–2/0 AWG	3/8	66	2	10	75	15534*	66	4.09 (103.9)	3.66 (93.0)	0.28 (7.1)	1.38 (35.1)	1.00 (25.4)
53065FL	4/0–250 kcmil	3/8	87H	2	10	112	15506**	87H	4.50 (114.3)	4.09 (103.9)	0.31 (7.9)	1.38 (35.1)	1.00 (25.4)

Diagram

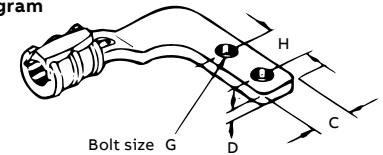

* TBM14M, 13100A, TBM15I with hex crimp dies.
 ** TBM15I with hex crimp dies only.



Grid-to-fence ground clamps

Bond copper conductors to steel or aluminum fence post or top rail of round fence posts.

- Provide quick, dependable installation at low installed cost
- Use no incendiary materials
- Body made from cast copper alloy with steel U-bolt



Cat. no.	Ground cable range (AWG)	Die code	Steel and aluminum line post range (in)
FG2040R2	2/0–3/0–4/0	76	2.00
FG2040R25	2/0–3/0–4/0	76	2.50
FG2040R3	2/0–3/0–4/0	76	3.00
FG210R2	#2–#1–1/0	66	2.00
FG210R25	#2–#1–1/0	66	2.50
FG210F3	#2–#1–1/0	66	3.00

Diagram

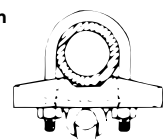

Install with hydraulic tooling with hex crimp dies.

Service post connectors



Type DS – Service post connectors, short stud application

The Blackburn line of service post connectors is designed for applications including steel structure, fence post or transformer grounding involving one or two cables. Service posts can also be used to tap one or two cables from bus bar.

Construction and ratings

Bolts used in the service post are machined from high-conductivity bronze alloy while the nuts are cold-formed from high-strength, corrosion-resistant copper alloy. Pressure bars are copper through 4/0 size, while copper alloy is used for 350 kcmil size and above. Bolts and nuts are of the traditional Blackburn hex design for easy installation.

Service post connectors are available in sizes accommodating AWG copper conductor ranges of #12–500 kcmil stranded (4 mm²–240 mm²) and #12–#2 solid (4 mm²–35 mm²).

The line includes both short and long stud versions for single and double conductor connectors.

- For copper to copper connections
- For grounding of steel structures, fence posts or transformers using one or two cables
- For tapping one or two cables from bus bar
- Hex design bolts are machined from high-conductivity bronze alloy
- Nuts and pressure bars are cold-formed from high-strength copper or copper alloy



Cat. no.		Conductor range stranded AWG (mm ²)		Conductor range solid AWG (mm ²)		Maximum diameter range (in.)	Stud size (in.)
Double conductor	Single conductor	Max.	Min.	Max.	Min.		
SP0DS	SP0SS	#8 (6)	#12 (4)	#8 (6)	#12 (4)	0.146–0.080	¼–20 x ½
SP1DS	SP1SS	#7 (10)	#10 (6)	#6 (10)	#10 (6)	0.170–0.102	¼–20 x ½
SP2DS	SP2SS	#5 (16)	#10 (6)	#4 (16)	#10 (6)	0.217–0.102	5/16–18 x 5/8
SP3DS	SP3SS	#3 (25)	#10 (6)	#2 (35)	#10 (6)	0.271–0.102	3/8–16 x 5/8
SP4DS	SP4SS	#1 (35)	#8(6)	#2 (35)	#8 (10)	0.332–0.128	3/8–16 x 5/8
SP5DS	SP5SS	1/0 (50)	#2 (35)	#2 (35)	–	0.385–0.259	½–13 x ¾
SP6DS	SP6SS	2/0 (70)	#2 (35)	#2 (35)	–	0.443–0.258	½–13 x ¾
SP8DS	SP8SS	4/0 (95)	#1 (35)	–	–	0.570–0.289	5/8–11 x 1
SP9DS	SP9SS	350 (150)	1/0 (70)	–	–	0.715–0.373	5/8–11 x 1
SP10DS	SP10SS	500 (240)	3/0 (95)	–	–	0.840–0.464	¾–10 x 1½

Service post connectors

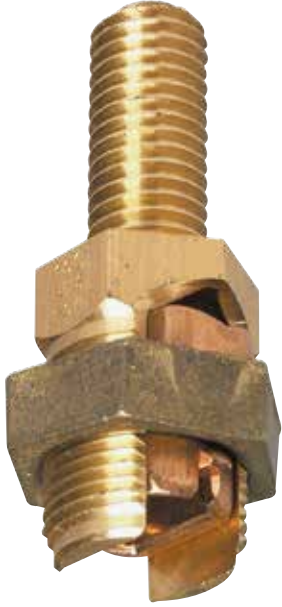

Type SP – Service post connectors, long stud

- For copper to copper connections
- For grounding of steel structures, fence posts or transformers using one or two cables
- For tapping one or two cables from bus bar
- Hex design bolts are machined from high-conductivity bronze alloy
- Nuts and pressure bars are cold-formed from high-strength copper or copper alloy
- Pressure bars are copper through 4/0 AWG size; copper alloy is used for 350 kcmil size and above
- Available in sizes accommodating AWG copper conductor ranges of #12–500 kcmil stranded (4 mm²–240 mm²) and #12–#2 solid (4 mm²–35 mm²)
- Line includes single conductor and double conductor connectors



Cat. no.		Conductor range stranded AWG (mm ²)		Conductor range solid AWG (mm ²)		Maximum diameter range (in.)	Stud size (in.)
Double conductor	Single conductor	Max.	Min.	Max.	Min.		
SP0DL	SP0SL	#8 (6)	#12 (4)	#8 (6)	#12 (4)	0.146–0.080	¼–20 x 1
SP1DL	SP1SL	#7 (10)	#10 (6)	#6 (10)	#10 (6)	0.170–0.102	¼–20 x 1
SP2DL	SP2SL	#5 (16)	#10 (6)	#4 (16)	#10 (6)	0.217–0.102	⅝–18 x 1
SP3DL	SP3SL	#3 (25)	#10 (6)	#2 (35)	#10 (6)	0.271–0.102	¾–16 x 1½
SP4DL	SP4SL	#1 (35)	#8 (6)	#2 (35)	#8 (10)	0.332–0.128	¾–16 x 1½
SP5DL	SP5SL	1/0 (50)	#2 (35)	#2 (35)	–	0.385–0.259	½–13 x 1¼
SP6DL	SP6SL	2/0 (70)	#2 (35)	#2 (35)	–	0.443–0.258	½–13 x 1¼
SP8DL	SP8SL	4/0 (95)	#1 (35)	–	–	0.570–0.289	¾–11 x 1½
SP9DL	SP9SL	350 (150)	1/0 (70)	–	–	0.715–0.373	¾–11 x 1½
SP10DL	SP10SL	500 (240)	3/0 (95)	–	–	0.840–0.464	¾–10 x 1¾

Transformer tank ground connectors



Type TTC –Transformer tank ground connectors

- Transformer grounding connectors are cast of high-conductivity bronze; ½ in.–13 stud fits all standard EEI-NEMA distribution transformers
- Eye bolt on TTC2 rotates to accommodate cable in either vertical or horizontal direction
- One size connector to handle full range of grounding conductors from #8 through 2/0 AWG str.
- No special tools required

Cat. no.	Conductor range				Stud thread size UNC-2A	Dimensions (in.)		
	Max. (AWG)	Min. (AWG)	Max. (mm ²)	Min. (mm ²)		A	B	C
TTC2	2/0 str.	#8 sol.	67.4	8.3	½ in.–13	1 ⁵ / ₆₄	1 ⁹ / ₆₄	1 ²¹ / ₃₂
TTC3	#1 str.	#10 sol.	42.4	5.2	½ in.–13	1 ³ / ₈	1 ³ / ₆₄	1 ¹ / ₁₆
TTC4+	#1 str.	#10 sol.	42.4	5.2	½ in.–13	1 ¹ / ₄	7/ ₈	1 ³ / ₈
TTC2P+	2/0 str.	#8 sol.	67.4	8.3	½ in.–13	1 ⁵ / ₆₄	1 ⁹ / ₆₄	1 ²¹ / ₃₂
TTC3P*	#1 str.	#10 sol.	42.4	5.2	½ in.–13	1 ³ / ₈	1 ³ / ₆₄	1 ¹ / ₁₆
TTC4P*	#1 str.	#10 sol.	42.4	5.2	½ in.–13	1 ¹ / ₄	7/ ₈	1 ³ / ₈

Diagrams

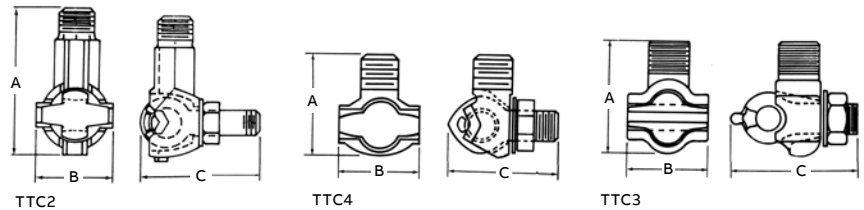

* Tin-plated.
+ RUS listed.

Conduit hubs



Conduit hubs

Cat. no.	Ground wire size (AWG)	Conduit/wire size
3930	#8 to #2	½ in. Conduit
3940	#8 to #2	¾ in. Conduit
3950	#8 to 3/0	1 in. Conduit
3951	#8 to 4/0	1¼ in. Conduit
3960	#8 to #4	Armored wire

Material: Malleable iron.



Type CH – Bronze conduit hubs

- Rugged cast bronze threaded hub
- Provide positive connection between rigid conduit and water system in conjunction with “J” clamp

Cat. no.	Conduit size (in.)	Conductor range (AWG)	
		Max.	Min.
CH12	½	#6 sol.	#10 sol.
CH34	¾	2/0 str.	#10 sol.
CH1BB	1	3/0 str.	#10 sol.

Lay-in lug connectors



Copper lay-in lug connectors

- Ideal for swimming pool grounding applications
- Carries “DB” marking for direct burial
- Open-faced design enables installer to quickly lay in the grounding conductor as a jumper to multiple conduits with no break in the ground conductor



Cat. no.	Conductor range		Stud size		Dimensions					
	AWG	mm ²	in.	mm	H		W		L	
					in.	mm	in.	mm	in.	mm
CULL414	4-14	16-1.5	0.22	5.59	0.78	19.81	0.38	9.65	1.07	27.18
CULL414TP*	4-14	16-1.5	0.22	5.59	0.78	19.81	0.38	9.65	1.07	27.18

Diagram

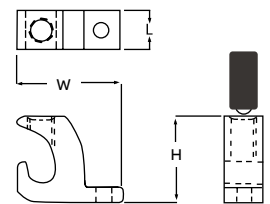

* Tin-plated.
90 °C rating.



Blackburn lay-in lug



Cat. no.	Conductor range		Stud size	
	AWG	mm ²	in.	mm
LL414	#4-#14	16-1.5	0.22	5.59
LL1014	1/0-#14	50-1.5	0.27	6.86
LL306	3/0-#6	70-16	0.33	8.38
LL2506	250-#6	120-16	0.33	8.38

These grounding connectors are dual rated for aluminum and copper conductors.
The open-face design allows the installer to quickly lay in the grounding conductor as a jumper.

Lay-in lug connectors



Mechanical lay-in ground connector



Cat. no.	Range (AWG or kcmil)	Torque
MLG25020	250 through 2/0 stranded	40 feet/pounds

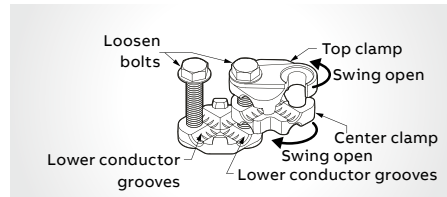

Step 1

- Open grounding connector by loosening bolts
- Swing top and center clamps to the side to expose lower conductor grooves.

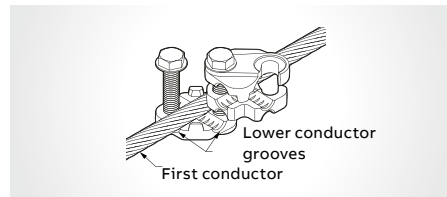

Step 2

- Lay in first conductor into lower conductor groove

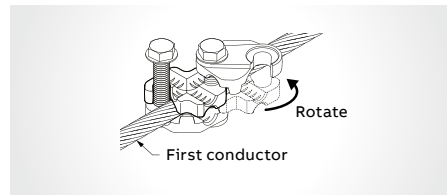

Step 3

- Rotate center clamp into position over first conductor

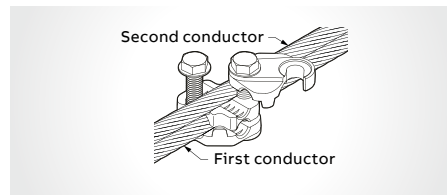

Step 4

- Lay in second conductor into center clamp conductor groove (parallel conductor style is shown)

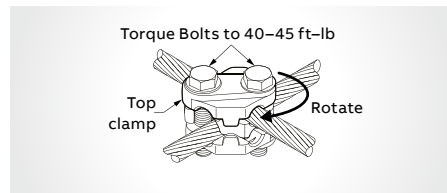

Step 5

- When conductors are in place, rotate top clamp over the second conductor and torque bolts to 40-45 ft-lb (cross conductor style is shown)

Ground plates



Galvanized grounding plates

- Made of high-quality steel, hot dip galvanized
- Major time and cost savings vs ground rods



Cat. no.	Description	Wire range (AWG)	Std. pkg.
1016TB	Galvanized grounding plate	#8 sol. to 3/0 str.	1
1016BTB	Galvanized grounding plate (complete with JAB34C connector)	#8 sol. to 3/0 str.	1

Diagrams

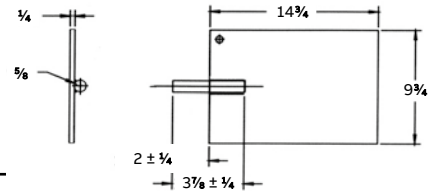

* CSA not applicable.



Ground electrode boxes

Cat. no.	Description
51628-TB	Pregalvanized steel
51629	Hot dip galvanized steel
51628-ALTA	Ground electrode box for Alberta only

14 gauge steel, 10 in. diameter, 12 in. depth.

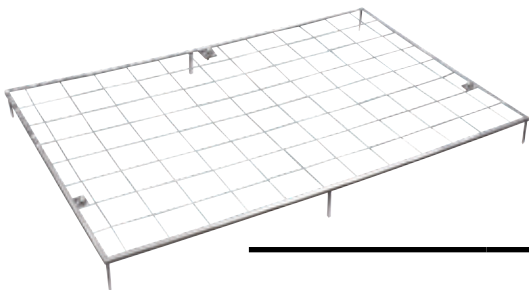

Metallic gradient control mats

- To reduce risk and prevent build up of dangerous potential differences between high-voltage equipment or structures and the user standing on the ground surface. CEC Rule 36-308.

Cat. no.	Description	Std. pkg.	Wt./100	
			lb	kg
64663	Mat with hardware	1	3000	1363

4 ft. x 6 ft. hot dip galvanized mat is made from 6 in. x 6 in. welded mesh, 1/4 in. diameter. With hardware 3 1/2 x 1/2 galvanized bolts, 3 galvanized washers and 3 galvanized nuts. Custom ground mat also available upon request.

Ground plates



Type GP – Copper pole bottom ground plates for multigrounded neutral construction

- More efficient than butt wrapping poles
- Made of electrolytic sheet copper
- Built-in high-pressure connector for ground lead, or supplied with #6 AWG copper pigtail pre-attached
- Plates are grooved for trapping moisture

Cat. no.	Min. (AWG)	Max. (AWG)	Pigtail wire range		Diameter of plate	
			Min. (mm ²)	Max. (mm ²)	(in.)	(mm)
GP100	#8	#2 sol.	6.3	25.6	7½	191
GP110			6.3	25.6	10	254
GP114			6.3	25.6	14	356
GP1003	#6 AWG solid Cu pigtail with 18 in. conductor		–	–	7½	191
GP1008	#6 AWG solid Cu pigtail with 18 in. conductor		–	–	7½	191
GP1108	#6 AWG solid Cu pigtail with 18 in. conductor		–	–	7½	254

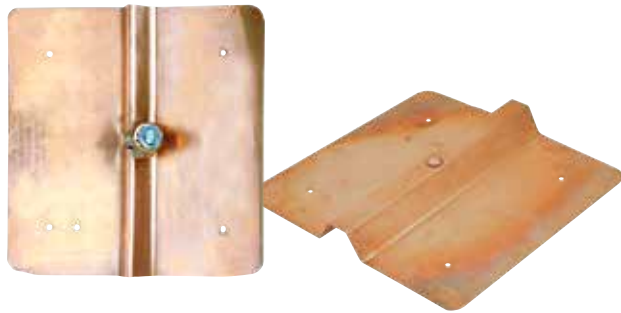

Type PB — Copper pole ground plates

- Installed on butt end of utility poles to provide an economical, low resistance neutral ground
- Installed cost considerably less than butt-wrapped poles. Plate portion fabricated of 0.025 in. pure copper.
- PBGW connector is eye-bolt type, cast of corrosion-resistant aluminum bronze alloy, with silicon bronze nut and lock washer. Riveted all-copper terminal lug is an integral part of the PBH, and provides the means of connection to the grounding conductor.

Cat. no.	Wire range (AWG)		Finished size (in.)	Surface area (sq. in.)
	Max.	Min.		
PBGW	2/0 str.	#10 sol.	7 x 7½	56
PBH*	#4 str.	#14 sol.	7 x 7½	56

* RUS Listed.

Ground tap connectors



Figure 6 compression ground tap connectors

- Material: High-conductivity copper
- Acceptable for direct burial



Cat. no.	Application (AWG or kcmil)		Cable to rebar application*		Dimensions in. (mm)		Dies for TBM14M, 13100A or TBM15I	Number of crimps
	Main	Tap	Main	Tap (AWG or kcmil)	T	H		
54855	1/0 str.–250 or ½ in.–¾ in. rod	#4 sol.–#2 str.	#3 Rebar ¾ thru ½ in. #4 rebar	#4 sol.–#2 str.	0.75 (19.1)	1.94 (49.3)	15G86R	1
54860		1/0 str.–2/0 str.	1/0 str.–2/0 str.	1/0 str.–2/0 str.	0.75 (19.1)	2.19 (55.6)	15G86R	1
54865-CK		3/0 str.–250		3/0 str.–250	0.75 (19.1)	2.19 (55.6)	15G86R	1
54875	#6 sol.–#2 str.	#6 sol.–#2 str.	–	–	0.75 (19.1)	2.56 (65.0)	15501A	1
54885	250–500 or ¾ in.–¾ in. rod	#4 sol.–#2 str.	–	–	0.75 (19.1)	1.94 (49.3)	15G126R	1
54890	250–500 or ¾ in.–¾ in. rod	1/0 str.–2/0 str.	#5 Rebar ¾ thru ¾ in. #6 rebar	1/0 str.–2/0 str.	0.75 (19.1)	2.13 (54.1)	15G126R	1
54895		3/0 str.–250	3/0 str.–250	3/0 str.–250	0.75 (19.1)	2.19 (55.6)	15G126R	1
54900		350–500		350–500	1.38 (35.1)	2.44 (62.0)	15G121R	3

Diagrams

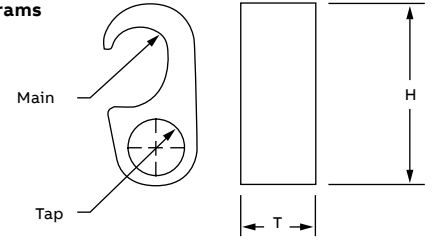

* CSA not applicable.
 Tin-plated version of galvanized ground rods available. Add suffix -TP to cat. no.
 Use 15500TB adaptor for TBM15I 15-ton tool.

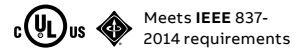

Cat. no.	Application		Dies for ABB tools (Figure 2)	L (in.)
	Main	Tap (AWG or kcmil)		
54865-CKN*	¾ in. rod	3/0 str.–250	15506SS	1½
54860N	¾ in. rod	1/0 str.–2/0 str.	15506SS	1½
54855N	¾ in. rod	#4 sol.–#2 str.	15506SS	1½
54875N	#6 sol.–#2 str.	#6 sol.–#2 str.	15517SS	1½

Diagrams

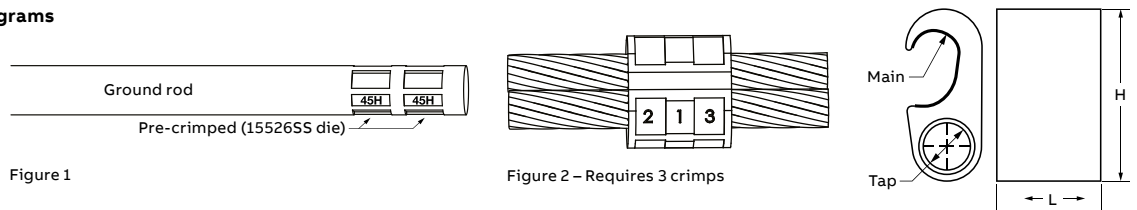

All parts ending by the letter N are IEEE837-2014 compliant.
 Use hydraulic tool 13100A, TBM14M TBM14CR-LI, TBM15CR-LI, TBM15, or TBM15I with die indicated in chart.
 Use 15500TB adaptor for TBM15I 15-ton tool.

IMPORTANT: For 54865-CKN only. To be in compliance with IEEE837-2014, the ground rod should be pre-crimped with die 15526SS (45H) as shown in Figure 1.

Ground rod tap connectors



Figure 8 compression ground rod tap connectors

- Material: High-conductivity copper
- Acceptable for direct burial



Cat. no.	A (in.) Ground rod	B Cable range (AWG or kcmil)	Dimensions in. (mm)		Dies for TBM14M 13100A or TBM15I	Number of crimps
			T	H		
GR12-202*	½	#2-2/0	0.88 (22.4)	1.94 (49.3)	15G121R	2
GR58-202*	⅝	#2-2/0	0.88 (22.4)	1.97 (50.0)	15G121R	2
GR34-202*	¾	#2-2/0	0.88 (22.4)	2.19 (55.6)	15G121R	2
GR1-202	1	#2-2/0	0.88 (22.4)	2.56 (65.0)	15G121R	2
GR12-40250*	½	4/0-250	0.88 (22.4)	1.94 (49.3)	15G121R	2
GR58-40250*	⅝	4/0-250	0.88 (22.4)	2.13 (54.1)	15G121R	2
GR34-40250*	¾	4/0-250	0.88 (22.4)	2.19 (55.6)	15G121R	2
GR1-40250	1	4/0-250	0.88 (22.4)	2.44 (62.0)	15G121R	2
GR58-300500*	⅝	300-500	0.88 (22.4)	2.13 (54.1)	15G121R	2
GR34-300500*	¾	300-500	0.88 (22.4)	2.44 (62.0)	15G121R	2
GR1-300500	1	300-500	0.88 (22.4)	2.69 (68.3)	15G121R	2

Diagrams

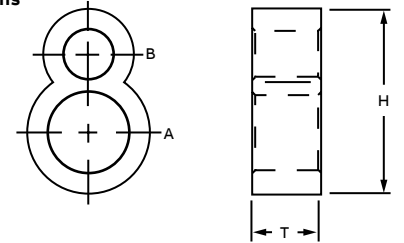

*Tin-plated version of galvanized ground rods available. Add suffix -TP to cat. no.
 Use 15500TB adaptor for TBM15I 15-ton tool.
 Optional ground rod knurling die for 14- and 15-ton tools: 15508. Knurling tool: 240-31565-94.

Ground rod to grid connectors

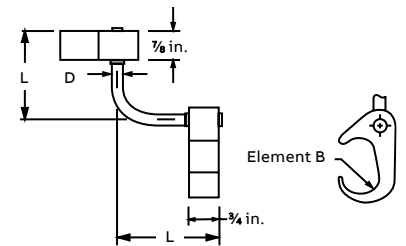

Figure 6 to 8 compression ground rod to grid connectors

DB    Meets IEEE 837 requirements

Cat. no.	A in. (mm) Ground rod	B Cable range (AWG or kcmil)	Dimensions in. (mm)		Dies for TBM14M, 13100A or TBM15I	
			D	L	Element A	Element B
54855LR12*	½ (12.7)	#2–250	0.31 (7.8)	2.50 (63.5)	15G121R	15G86R
54885LR12*	½ (12.7)	250–500	0.31 (7.8)	2.50 (63.5)	15G121R	15G126R
54865LR58*	¾ (16.0)	#2–250	0.31 (7.8)	2.50 (63.5)	15G121R	15G86R
54895LR58*	¾ (16.0)	250–500	0.31 (7.8)	2.50 (63.5)	15G121R	15G126R
54875LR34*	¾ (19.1)	#2–250	0.50 (12.7)	2.63 (66.8)	15G121R	15G86R
54900LR34*	¾ (19.1)	250–500	0.50 (12.7)	2.63 (66.8)	15G121R	15G126R
54910LR100	1 (25.4)	#2–250	0.50 (12.7)	2.63 (66.8)	15G121R	15G86R
54920LR100	1 (25.4)	250–500	0.50 (12.7)	2.63 (66.8)	15G121R	15G126R

Diagrams



*Tin-plated version available for galvanized ground rods. Add suffix -TP to cat. no.

Ground grid connectors

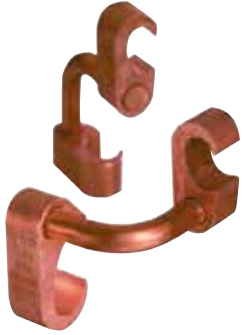

Figure 6 to 6 compression ground grid connectors

- Material: High-conductivity copper
- Acceptable for direct burial



Cat. no.	A Cable range (AWG or kcmil)	B to cable range (AWG or kcmil)	B to ground rod	B to rebar	D (in.)	T (in.)	Dies for ABB tool*			
							Number A of crimps	Number B of crimps	Number A of crimps	Number B of crimps
54900L	250-500	250-500	5/8 in.-3/4 in. rod	#5-#6 (5/8 in.-3/4 in.)	3/4	1 1/8	15G121R	3	15G121R	3
54895L	#2 str.-250	250-500	5/8 in.-3/4 in. rod	#5-#6 (5/8 in.-3/4 in.)	1/2	3/4	15G86R	1	15G126R	1
54885L	#6 sol.-#2 str.	250-500	5/8 in.-3/4 in. rod	#5-#6 (5/8 in.-3/4 in.)	5/8	3/4	15501A	1	15G126R	1
54875L	#2 str.-250	#2 str.-250	1/2 in.-5/8 in. rod	#3-#4 (3/8 in.-1/2 in.)	1/2	3/4	15G86R	1	15G86R	1
54865L	#6 sol.-#2 str.	#1 str.-250	1/2 in.-5/8 in. rod	#3-#4 (3/8 in.-1/2 in.)	5/16	3/4	15501A	1	15G86R	1
54855L	#6 sol.-#2 str.	#6 sol.-#2 str.	-	-	5/16	3/4	15501A	1	15501A	1

Diagrams

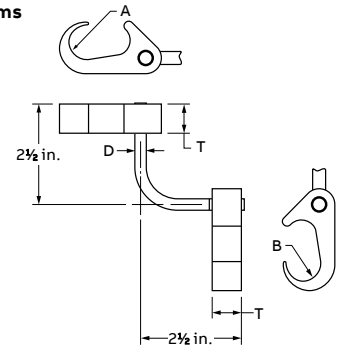

*Use hydraulic tool 13100A, TBM14CR-LI, TBM14M, TBM15CR-LI, TBM15, or TBM15I or with die marked on cat. no. Use 15500TB adaptor for 15-ton tool TBM15I.

Cable-to-cable or cable-to-rod connectors

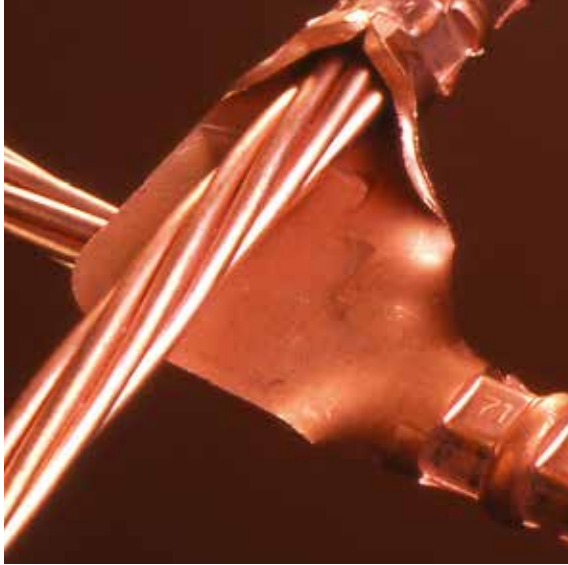

One-piece construction for cable-to-cable, cable-to-rod, “T” and “X” connections

- Suitable for direct burial or in concrete
- Replaces exothermic welds
- Made from high-conductivity wrought copper



Cat. no.	Cable to cable range							Rod to cable range						
	Main (AWG or kcmil)	Die code	TBM14 and 15 Die cat. no.	Number of crimps	Branch (AWG or kcmil)	Die code	TBM14 and 15 Die cat. no.	Number of crimps	Ground rod (in.)	Die code	TBM14 and 15 Die cat. no.	Cable (AWG or kcmil)	Die code	TBM14 and 15 Die cat. no.
GG21-21	#2 or #1	45	15526SS	2	#2 or #1	45	15526SS	2	-	-	-	-	-	-
GG10-10	1/0	54	15511SS	2	1/0	54	15511SS	2	-	-	-	-	-	-
GG2030-21	2/0 or 3/0	60	15532SS	2	#2 or #1	50-45	15526SS 15530SS	2	-	-	-	-	-	-
GG2030-10	2/0 or 3/0	60	15532SS	2	1/0	54H	15511SS	2	-	-	-	-	-	-
GG2030-2030	2/0 or 3/0	60	15532SS	2	2/0-3/0	60	15532SS	2	-	-	-	-	-	-
GG40250-21	4/0 or 250	71H	15514SS		#2	45 50	15526SS 15530SS	2	1/2 5/8	71 80H	15514SS 15517SS	#2 or #1 #2 or #1	45 50	15526SS 15530SS
GG40250-10	4/0 or 250	71H	15514SS		1/0	54H	15511SS	2	1/2 5/8	71 80H	15514SS 15517SS	1/0	54	15511SS
GG40250-2030	4/0 or 250	71H	15514SS		2/0 or 3/0	60	15532SS	2	1/2 5/8	71 80H	15514SS 15517SS	2/0 or 3/0 2/0 or 3/0	60 60	15532SS 15532SS
GG40250-40250	4/0 or 250	71H	15514SS		4/0 or 250	71H	15514SS	2	1/2 5/8	71 80H	15514SS 15517SS	4/0 or 250 4/0 or 250 4/0 or 250	71H 71H 71H	15514SS 15514SS 15514SS
GG500-40250	500	87H	15506SS		4/0 or 250	71H	15514SS	2	3/4 5/8	87H	15506SS	4/0 or 250 4/0 or 250 4/0 or 250	71H 71H 71H	15514SS 15514SS 15514SS
GG500-500	500	87H	15506SS		500	87H	15506SS	2	3/4 5/8	87H	15506SS	500	87H	15506SS
GG500-350	500	87H	15506SS		350	80H	15606SS	2	3/4 5/8	87H	15506SS	350	80H	15506SS
GG500-2030	500	87H	15506SS		2/0 or 3/0	60	15532SS	2	3/4 5/8	87H	-	2/0 or 3/0	60	15532SS
GG350-350	350	80H	15506SS		350	80H	15606SS	2	-	-	-	-	-	-

Uses 15500TB adaptor for 15-ton tools.

Optional ground rod knurling die or TBM14 and 15 tools: 15508SS.

Optional ground rod knurling tool: 240-31565-94.

Two cables to ground rod



For connecting perpendicular runs of stranded copper cable to ground rod



Cat. no.	Cable and rod installing dies for TBM14 and 15										
	Cable size (AWG or kcmil)		Ground rod dia. (in.)	Ground cable			Ground rod		Overall dimensions in. (mm)		
	Main	Tap		Die code	Cat. no.	Number of crimps	Die code	Cat. no.	Number of crimps	L1	L2
53065-58GR	250 or 4/0	250 or 4/0	$\frac{3}{8}$ and $\frac{1}{2}$	87H	15506SS	2	87H	15506SS	2	4.94 (125.5)	3.25 (82.6)
53065-34GR	250 or 4/0	250 or 4/0	$\frac{3}{4}$	87H	15515SS	2	106H	15515SS	2	4.94 (125.5)	3.25 (82.6)

Diagram

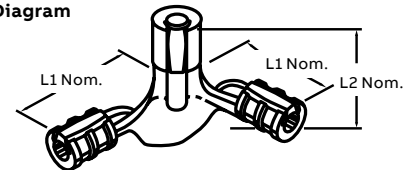

Use T&B hydraulic tools with hex crimp dies.

Optional ground rod knurling die for TBM14 and 15 Tools: 15508SS.

Optional ground rod knurling Tool: 240-31565-94.

Use 15500TB adaptor for TBM15-Ton Tool.

Cable size (AWG or kcmil)	Reinforcing rod size	Copperweld* conductor size
#2, #1	—	3 #8 or 3 #6
1/0, 2/0	#3	$\frac{3}{8}$ (7 #8) or $\frac{1}{16}$ (7 #7)
4/0, 250	#4	$\frac{7}{16}$ (19 #9) or (7 #5)
300–350	#5	$2\frac{1}{32}$ (19 #8) or $\frac{5}{8}$ (7 #4)
500	#6	$1\frac{3}{16}$ (19 #6)

* Reg. Trademark Copperweld Corporation.

UL listed for use with cast copper connectors.

Grounding grid connectors



53065



53055

Heavy-duty cast copper**



Cat. no.	Rod to cable range		Cable to cable range rod (AWG or kcmil)		Cable and rod installing dies for TBM14 and 15						Overall dimensions in. (mm)	
	Rod size (in.)	Cable range (AWG or kcmil)	Main	Branch	Die code	Cat. no.	Number of crimps	Die code	Cat. no.	Number of crimps	L1	L2
53055	-	-	1/0-2/0	1/0-2/0	-	-	-	66	15534SS	1	3.88 (98.6)	3.88 (98.6)
53059*	½-¾	#2-#1	4/0-250	#2-#1	87H	15506SS	2	54H	15511SS	2	4.16 (105.7)	4.56 (115.8)
53060*	½-¾	1/0-2/0	4/0-250	1/0-2/0	87H	15506SS	2	87H	15506SS	2	4.44 (112.8)	4.44 (112.8)
53065*	½-¾	4/0-250	4/0-250	4/0-250	87H	15506SS	2	87H				
53069*	¾	1/0-2/0	300-350	1/0-2/0	106H	15515SS	2	66	15534SS	1	4.59 (116.6)	4.59 (116.6)
53071*	¾	4/0-250	300-350	4/0-250	106H	15515SS	2	106H	15515SS	2	5.25 (133.4)	4.78 (121.4)
53073*	1	1/0-2/0	500	1/0-2/0	125H	15603	3	66	15534SS	1	4.81 (122.2)	4.88 (124.0)
53075*	1	4/0-250	500	4/0-250	125H	15603	3	87H	15506SS	2	6.56 (166.6)	5.00 (127.0)
53080*	1	500	500	500	125H	15603	3	125H	15603	3	5.19 (131.8)	5.19 (131.8)

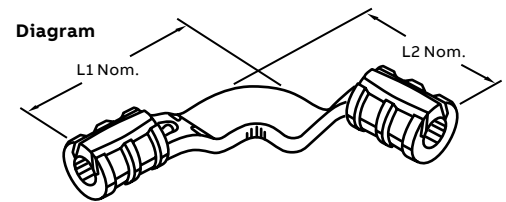

* 4/0-250 wire barrels suitable for ½ in. and ¾ in. rod, 300-500 kcmil wire barrels suitable for ¾ in. rods, 500 kcmil wire barrels suitable for 1 in. rods.

** Do not meet IEEE837.

Cat. no. 15500TB adaptor is required for all 15500SS series dies, not for 15600SS series, crimp with 15-ton tools.

Hydraulic tools only.

C-Taps



DB    Meets IEEE 837 requirements

Cat. no.	Cable range (AWG or kcmil)		Dimensions in. (mm)		Dies for TBM14M, 13100A or TBM15I* Crimps
	Main	Tap	H	L	
CTP22	#6 sol.-#2 str.	#6 sol.-#2 str.**	1.16 (29.5)	0.75 (19.1)	HBKC 1
CTP202	#1 str.-2/0 str.	#6 sol.-#2 str.**	1.41 (35.8)	0.75 (19.1)	15501A 1
CTP2020	#1 str.-2/0 str.	#1 str.-2/0 str.	1.54 (39.1)	0.75 (19.1)	15501A 1
CTP25020	3/0 str.-250	#6 sol.-2/0**	1.97 (50.0)	0.75 (19.1)	15G86R 1
CTP250250	3/0 str.-250	3/0 str.-250	2.06 (52.3)	0.88 (22.4)	15G86R 1
CTP50020	300-500	#6 sol.-2/0**	2.42 (61.5)	0.88 (22.4)	15G121R 2
CTP500250	300-500	3/0 str.-250	2.67 (67.8)	0.88 (22.4)	15G121R 2
CTP500500†	300-500	300-500	2.91 (73.9)	1.10 (27.9)	15G121R 3

Diagrams

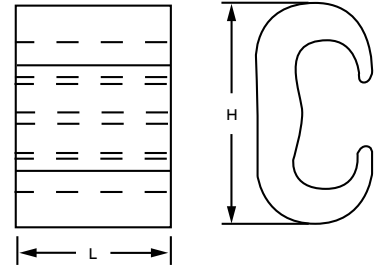

* Cat. no. 15500 adaptor required if using TBM15I and 155XX series dies.
 ** #6 AWG branch must be doubled.
 † Must use TBM15I tool
 Material: High-conductivity copper.

C-Taps



DB c Meets IEEE 837-2014 requirements

Cat. no.	Ø A cable (AWG or kcmil)	Ø B cable (AWG or kcmil)	H (in.)	L (in.)	Crimps	Dies for tools*
CTP22N	#6 sol.-#2 str.	#6 sol.-#2 str.	1 ³ / ₃₂	1 ¹ / ₂	3	15534SS (Fig.1)
CTP202N	#1 str.-2/0 str.	#6 sol.-#2 str.	1 ¹⁹ / ₃₂	1 ¹ / ₂	3	15517SS (Fig.1)
CTP2020N	#1 str.-2/0 str.	#1 str.-2/0 str.	1 ⁹ / ₁₆	1 ¹ / ₂	3	15517SS (Fig.1)
CTP25020N	3/0 str.-250	#1 str.-2/0 str.	1 ³ / ₃₂	1 ¹ / ₂	3	15506SS (Fig.1)
CTP250250N†	3/0 str.-250	3/0 str.-250	2 ¹ / ₁₆	1 ¹ / ₂	3	15506SS (Fig.1)
CTP500250N	300-500	3/0 str.-250	2.72	2.5	5	15603SS
CTP50020N	300-500	#6 sol.-2/0 str.	2.42	2.5	5	15603SS
CTP500500N**	300-500	300-500	2.92	2.5	5	15G121N

Diagrams

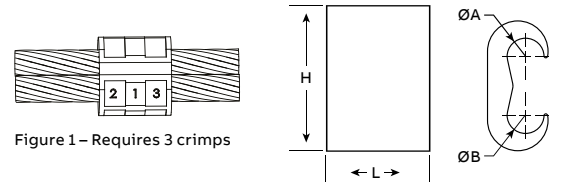

Figure 1 – Requires 3 crimps

* These dies may be used with the TBM15CR-LI or TBM15I compression tools. Please note that the die adapter 15500-TB is required for use with these tools.

**Can be used with 3/4 in. (17.3 mm) copper-clad ground rod. The ground rod must be pre-crimped with die 15507SS to comply with IEEE 837-2014.

† Can be used with 5/8 in. (15.8 mm) copper-clad ground rod. The ground rod must be pre-crimped with die 15526SS to comply with IEEE 837-2014.



Copper C-crimps wire combinations**



Cat. no.	Cable range (AWG)		Die index	Manual tool OD series	Installing die 14- and 15-ton tools	Dimensions in. (mm)	
	Run	Tap				L	H
BC48	6 sol.-4 str.	8 sol.-8 str.	BG or 5/8	BY31	B58CS	0.64 (16.3)	0.56 (14.2)
BC46-BB	6 sol.-4 str.	6 sol.-6 str.	BG or 5/8	BY31	B58CS	0.64 (16.3)	0.75 (19.1)
BC44	6 sol.-4 str.	4 sol.-4 str.	BG or 5/8	BY31	B58CS	0.64 (16.3)	0.80 (20.3)
BC24	2 sol.-2 str.	8 sol.-4 str.	C	BY33	HBKC	0.75 (19.1)	0.98 (24.9)
BC22	2 sol.-2 str.	2 sol.-2 str.	C	BY33	HBKC	0.75 (19.1)	1.05 (26.7)
BC202	1/0 sol.-2/0 str.	8 sol.-2 str.	E or O	-	HO	0.94 (23.9)	1.31 (33.3)
BC2020-BB	1/0 sol.-2/0 str.	1/0 str.-2/0 str.	E or O	-	HO	0.94 (23.9)	1.34 (34.0)
BC402	3/0 str.-4/0 str.	6 sol.-2 str.	F or D3	-	HD	1.06 (26.9)	1.63 (41.4)
BC4020	3/0 str.-4/0 str.	1/0 sol.-2/0 str.	F or D3	-	HD	1.06 (26.9)	1.63 (41.4)
BC4040	3/0 str.-4/0 str.	3/0 sol.-4/0 str.	F or D3	-	HD	1.06 (26.9)	1.63 (41.4)

Diagrams

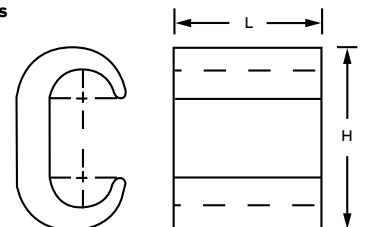

**Do not meet IEEE 837.

C-Taps



Small size



Cat. no.	Code wire comb. (AWG)		Die		Insulation choice		Dimensions in. (mm)		Colour code			
	Main	Branch	Group 1	TBM62PCR-LI	Smart™ Tools	Group 2	Group 3	Adhesive		Shrink tubing	L	H
54705	#12	#14	6TON21SS	TBM6221	–	•	•	AC5X3	HS12-6	0.31 (7.9)	0.31 (7.9)	Red
	#14	#16	6TON21SS	TBM6221	–	•	•	AC5X3	HS12-6	0.31 (7.9)	0.31 (7.9)	
54710	#10	#10	6TON24SS	TBM6224	–	•	•	AC5X3	HS12-6	0.56 (14,2)	0.44 (11.2)	Blue
	#8	#12	6TON24SS	TBM6224	–	•	•	AC5X3	HS12-6	0.56 (14,2)	0.44 (11.2)	
54715	#6	#10, 12	6TON29SS	TBM6229	–	•	•	AC5X3	HS12-6	0.56 (14,2)	0.63 (16.0)	Grey
	#8	#8, 10, 12	6TON29SS	TBM6229	–	•	•	AC5X3	HS12-6	0.56 (14,2)	0.63 (16.0)	
54720	#4 ou 5		6TON33SS	TBM6233	TBM8-750C20	•	•	AC5X3	HS6-1	1.16 (29.5)	0.69 (17.5)	Brown
	#6	#6, 8	6TON33SS	TBM6233	TBM8-750C20	•	•	AC5X3	HS6-1	1.16 (29.5)	0.69 (17.5)	
54725	#3	#6, 8, 10, 12***	6TON37SS	TBM6237	TBM8-750C2530	•	•	AC5X3	HS6-1	1.16 (29.5)	0.81 (20.6)	Green
	#4 ou 5	#6, 5	6TON37SS	TBM6237	TBM8-750C2530	•	•	AC5X3	HS6-1	1.16 (29.5)	0.81 (20.6)	
54730	#2	#6, 8, 10, 12	6TON42SS	TBM6242	TBM8-750C2530	•	•	AC5X3	HS6-1	1.16 (29.5)	0.84 (21.3)	Pink
	#3	#5	6TON42SS	TBM6242	TBM8-750C2530	•	•	AC5X3	HS6-1	1.16 (29.5)	0.84 (21.3)	
	#4	#3	6TON42SS	TBM6242	TBM8-750C2530	•	•	AC5X3	HS6-1	1.16 (29.5)	0.84 (21.3)	
54735	#1	#4, 5, 6, 8, 10, 12	6TON45SS	TBM6245	TBM8-750C3540	•	•	AC5X3	HS6-1	0.06 (1.5)	0.88 (22.4)	Black
	#2	#4, 5	6TON45SS	TBM6245	TBM8-750C3540	•	•	AC5X3	HS4-30	0.06 (1.5)	0.88 (22.4)	
	#3	#3, 4	6TON45SS	TBM6245	TBM8-750C3540	•	•	AC5X3	HS4-30	0.06 (1.5)	0.88 (22.4)	
54740	1/0	#4, 5, 6, 8, 10, 12	6TON50SS	TBM6250	TBM8-750C3540	•	•	AC5X3	HS4-30	1.69 (42,9)	0.97 (24.6)	Orange
	#1	#3, 4	6TON50SS	TBM6250	TBM8-750C3540	•	•	AC5X3	HS4-30	1.69 (42,9)	0.97 (24.6)	
	#2	#2, 3	6TON50SS	TBM6250	TBM8-750C3540	•	•	AC5X3	HS4-30	1.69 (42,9)	0.97 (24.6)	
54745	2/0	#3, 4, 5, 6, 8, 10, 12	6TON54SS	TBM6254	TBM8-750C4550	•	•	AC5X3	HS4-30	1.69 (42,9)	1.06 (26.9)	Purple
	1/0	#2, 3	6TON54SS	TBM6254	TBM8-750C4550	•	•	AC5X3	HS4-30	1.69 (42,9)	1.06 (26.9)	
	#1	#1, 3	6TON54SS	TBM6254	TBM8-750C4550	•	•	AC5X3	HS4-30	1.69 (42,9)	1.06 (26.9)	
54750	3/0	#2, 3, 4, 5, 6, 8, 10, 12	6TON62SS	TBM6262	TBM8-750C4550	•	•	AC5X3	HS4-30	1.69 (42,9)	1.19 (30.2)	Yellow
	2/0	#1, 2	6TON62SS	TBM6262	TBM8-750C4550	•	•	AC5X3	HS4-30	1.69 (42,9)	1.19 (30.2)	
	1/0	1/0, 1	6TON62SS	TBM6262	TBM8-750C4550	•	•	AC5X3	HS4-30	1.69 (42,9)	1.19 (30.2)	

Diagrams

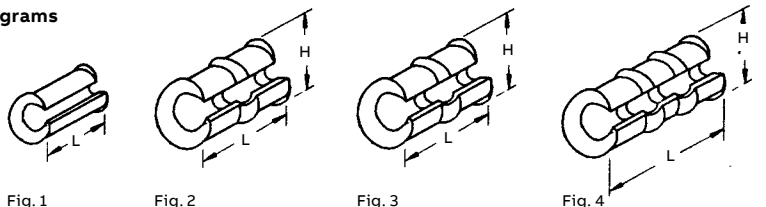

*** When using #3 AWG on main and #12 AWG on branch with Smart Tools and dies, #12 AWG wire must be doubled (hair-pinned) and placed on branch for crimping.

Group 1 = TBM6H, TBM62PCR-LI, TBM62CR-LI, TBM6UNICR-LI.

Group 2 = TBM45S, TBM41E (require 2 compressions within each crimp area).

Group 3 = TBM4/4S, TBM5S, TBM6S, TBM8/8S, TBM6H (require 1 compression within each crimp area).

C-Taps



Certified to 600 V

- More economical than other taps and split bolts in terms of purchase, inventory, installation time, insulation and maintenance
- Color-coded for easy matching with proper die
- Barely larger than conductor insulation once installed

Material – High-conductivity wrought copper

Finish – Plain



Large size

Cat. no.	Wire size (AWG or kcmil)		Dimensions in. (mm)			Installing die			No. of crimps	Colour code
	Main	Branch	C	D	E	Tool	Cat. no.	Die code		
54755	#1	#1	1.93 (49.0)	0.75 (19.1)	0.53 (13.5)	TBM14M	15512SS	76	1	Blue
	1/0	1/0-#2				TBM15I	15512SS*	76		
	2/0	2/0-#3				TBM12	TBM12D-4	76		
	3/0	1/0-#6				13100A	15512SS	76		
	4/0	#1-#8								
54760	2/0	2/0-#1	1.43 (36.3)	0.75 (19.1)	0.59 (15.0)	TBM14M	15506SS	87H	2	Brown
	3/0	3/0-#3				TBM15I	15506SS*	87H		
	4/0	4/0-#4				TBM12	TBM12D-3	87H		
	250	#1-#8				13100A	15506SS	87H		
54765	2/0	2/0-#1	1.68 (42.7)	1.00 (25.4)	0.64 (16.3)	TBM14M	15505SS	99H	2	Pink
	3/0	3/0-#2				TBM15I	15505SS*	99H		
	4/0	4/0-#4				TBM12	TBM12D-2	99H		
	250	3/0-#6				13100A	15505SS	99H		
	300	2/0-#8								
54770	4/0	4/0-2/0	1.68 (42.7)	1.00 (25.4)	0.68 (17.3)	TBM14M	15515SS	106H	2	Black
	250	250-#1				TBM15I	15515SS*	106H		
	300	4/0-#4				TBM12	TBM12D-2	106H		
	350	3/0-#6				13100A	15515SS	106H		
54775**	250	250	1.88 (47.8)	1.25 (31.8)	0.81 (20.6)	TBM14M	15504SS	115H	2	Yellow
	300	300-3/0				TBM15I	15504SS*	115H		
	350	350-1/0				TBM12	TBM12D-1	115H		
	400	300-#2				13100A	15504SS	115H		
	450	250-#4								
	500	250-#6								
54780	350	350-4/0	2.18 (55.4)	1.25 (31.8)	0.82 (20.08)	TBM15I	15603	125H	2	N/A
	400	400-2/0								
	450	450-#1								
	500	500-#2								
54785	750	4/0-#6	2.12 (53.8)	2.00 (50.8)	1.00 (25.4)	TBM15I	15603	125H	3	N/A
54790	750	750-4/0	2.68 (68.1)	2.00 (50.8)	1.31 (33.3)	TBM15I	15603	125H	3	N/A

Diagrams

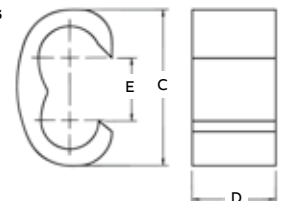

UL approved for direct burial.

For covers see the Color-Keyed compression connector system catalogue.

Taps can be supplied tin-plated. Add suffix "TP" to any cat. no. (i.e. 54725TP).

* Cat. no. 15500TB adaptor required if using TBM15I and 155xx series dies.

** #6 AWG branch must be doubled.

Tooling and die selector chart, see the Color-Keyed tools, dies and kits catalogue.

Copper lugs

Heavy-duty two-hole NEMA lugs



- Heavy-wall lugs for grounding and other critical applications
- Able to handle the most severe heavy-loading applications
- Ease cable insertion

Heavy-duty two-hole NEMA lugs

Meets IEEE 837 -2014 requirements

Cat. no.	Wire size (AWG or kcmil)	Installing dies*	Dimensions (in.)			
			B	L	P	W
HDL 2 N	#2	15508SS	1½	5¼	3	13/16
HDL 1 N	#1	15526SS	1½	5¼	3	13/16
HDL 1/0 N	1/0	15530SS	1½	5¼	3	13/16
HDL 2/0 N	2/0	15511SS	1¾	5½	3	15/16
HDL 3/0 N	3/0	15532SS	1 ¹¹ / ₁₆	5 ³ / ₁₆	3	1
HDL 4/0 N	4/0	15514SS	1¾	5 ⁵ / ₈	3	1 ¹ / ₈
HDL 250 N	250	15517SS	1¾	5 ⁵ / ₈	3	1 ¹ / ₄
HDL 300 N	300	15506SS	2¼	5 ¹³ / ₁₆	3	1 ³ / ₈
HDL 350 N	350	15503SS	2 ⁵ / ₁₆	6 ⁹ / ₁₆	3	1 ¹ / ₁₆
HDL 500 N	500	15609SS	2 ⁵ / ₈	6 ³ / ₈	3	1 ³ / ₄
HDL 750 N**	750	Consultez votre représentant ABB.	3 ⁵ / ₈	7 ³ / ₁₆	3	2 ³ / ₁₆
HDL 1000 N**	1,000	Consultez votre représentant ABB.	4 ⁵ / ₈	9 ⁵ / ₈	3 ⁵ / ₈	2 ⁵ / ₈

Diagram

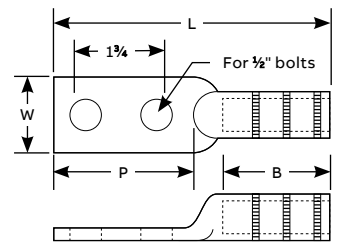

Note: For tin plating, add suffix "-TN" after the catalogue number.
For oxide-inhibiting compound, contact your ABB representative.

*These dies may be used with the TBM15CR-LI or TBM15I compression tools. Please note that the die adapter 15500-TB is required for use with these tools.

** Do not meet IEEE 837-2014 requirements.

Pigtail connectors

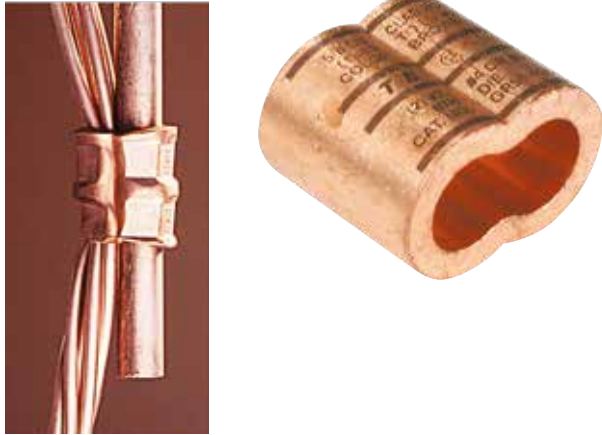

Hex compression intimately bonds directly to copper-clad ground rod

- Figure 8 connectors
- Conforms to IEEE 837 standard
- UL listed

When connecting cable to copper-clad ground rod for direct burial or in concrete, the connector shall be wrought copper with minimum conductivity of 99% I.A.C.S., such as ABB series GR12-306. Hex compression with die code embossing shall be used.



Cat. no.	Cable range (AWG)	Copper clad ground rod (in.)	Die code for TBM14M, TBM15, 13100A or TBM15I	No. of crimps	Die cat. no.
GR12-306	One cable: 3/0 to #6 Two cables: #2 to #6	1/2	87H	2	15506
GR58-406	One cable: 4/0 to #6 Two cables: #2 to #6	5/8	87H	2	15506
GR34-4010	One cable: 4/0 to 1/0	3/4	99H	2	15505



Ground plates



Cat. no.	Fig.	Cable range (AWG or kcmil)	H in. (mm)	No. of crimps	Die code for 14- and 15-ton tools
GP2250-2	1	#2-250	3.63 (92.2)	1	15G86R
GP2250-4	2	#2-250	4.22 (107.2)	1	15G86R
GP250500-2	1	250-500	3.63 (92.2)	2	15G126R
GP250500-4	2	250-500	4.22 (107.2)	2	15G126R

Diagrams

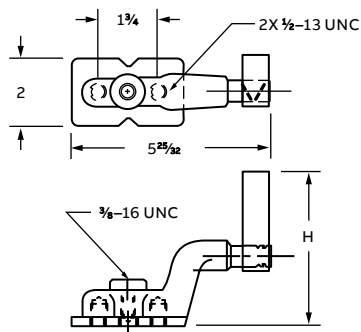

Figure 1

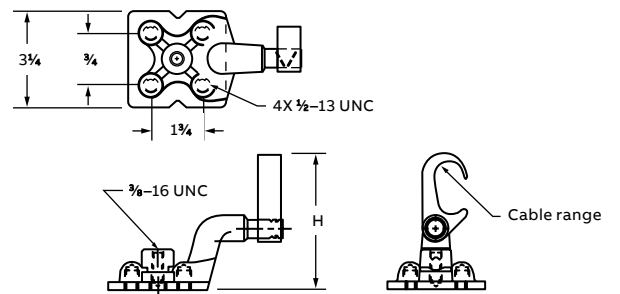

Figure 2

Grounding studs



Type TBGS structural grounding studs

Knurling ensures excellent mechanical pull-out and electrical continuity.

- Easily welded to steel structures with minimal construction welding equipment
- Connect to grounding conductors with appropriate ABB grounding connectors
- Knurled portion of stud resists pull-out and provides electrical continuity to ensure the integrity of the grounding circuit
- Constructed of high-strength steel and coated with corrosion-resistant copper cyanide

Cat. no.	Rod size (in.)
TBGS-14	0.25
TBGS-38	0.38
TBGS-58	0.63
TBGS-34	0.75

Diagrams

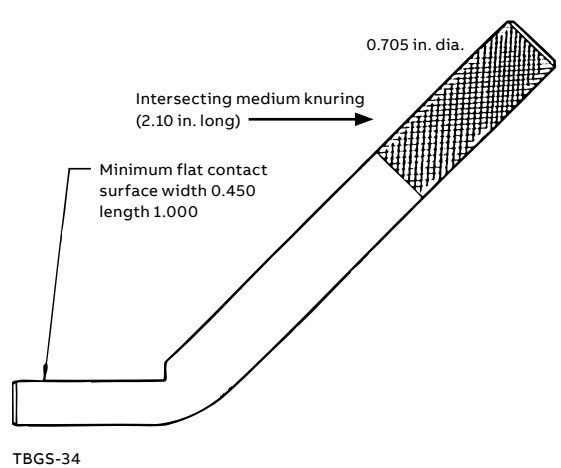
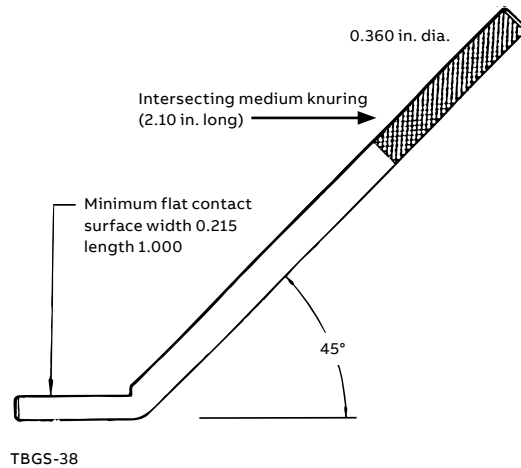
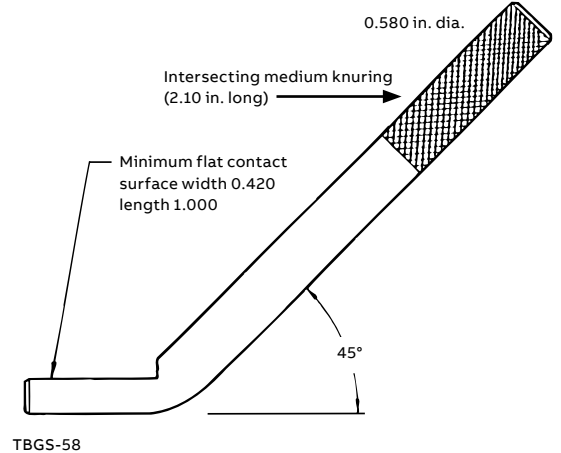
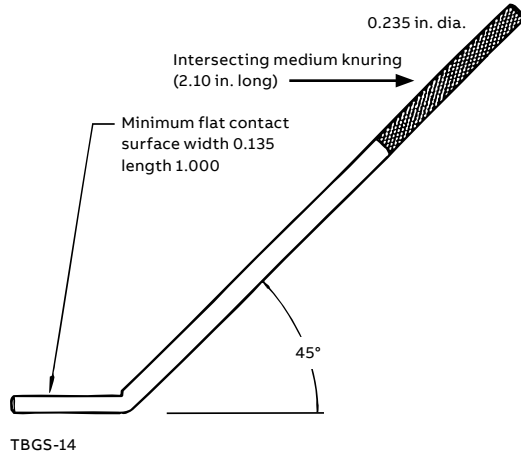

Bus bar connectors

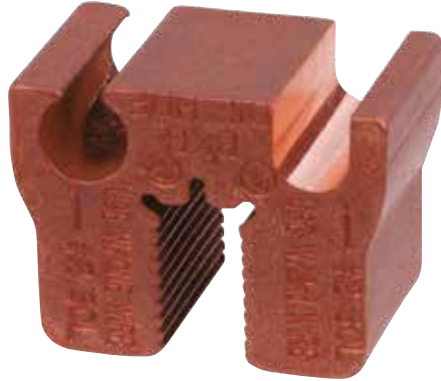

Cuts installation time in half – with results superior to conventional connectors

- Unique
- Fast and easy installation
- Superior low-resistance, high-conductivity connections
- Install with conventional compression tools
- Produce a permanent connection with any combination of copper from #6 to #2 AWG solid or stranded conductors, to ¼ in. copper bus bar
- Made from pure wrought copper and prefilled with oxide inhibitor
- CSA certified and UL listed
- Installed with die HDF

EZGround bus bar connectors install in less than 2 minutes with one easy crimp. The connector attaches directly to the bus, saving the labor-intensive process of drilling and tapping. The unique jaw interface of the EZGround bus bar connector grips the copper bus, resulting in a low-resistance, high-conductivity connection. The EZGround bus bar connectors can be used in OEM applications or telecom applications – cellular, PCS and others. They provide a continuous ground to the copper bus bar, making them ideal for tower applications. The design enables installation in virtually any position, horizontal or vertical, and is suitable for inside and outside plant use. Installation can be completed using tool TBM14, TBM14MC or TBM14CR-LI.

Busbar connectors



Cat. no.	Ground bus bar (in.)	Conductor range (AWG)	Tools	Die	Std. pkg. qty.
GBBC22	¼	#2-#2	TBM14M, TBM14MC, TBM14CR-LI	HDF	1
GBBC26	¼	#6-#2	TBM14M, TBM14MC, TBM14CR-LI	HDF	1

Diagrams

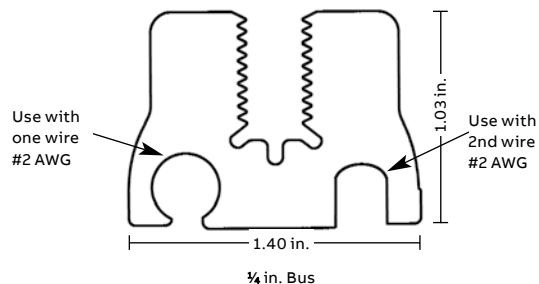

Cat. no. GBBC22

Use this side of the connector when using only one wire.

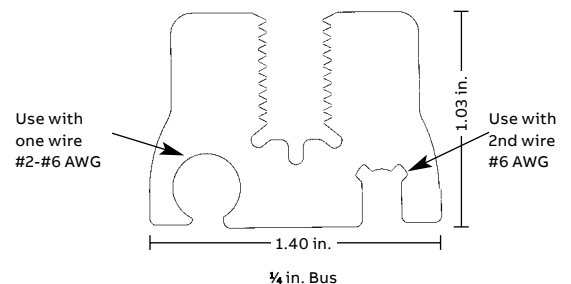

Cat. no. GBBC26

Use this side of the connector only when using two wires.

Ground rods



Galvanized ground rods

- Made of high-strength quality cold-drawn steel (1035) hot dip galvanized
- Meets ANSI CI35.30-1979 requirements
- Stainless steel rods are also available (for more detailed information, contact your ABB regional sales office)

Cat. no.	Trade size		Rod size (nominal diameter x length)		Plating thickness (mils)	Standard packaging	Weight per 100	
	in.	ft.	mm	m			lb	kg
GR5006	½	6	12.7	1.8	4	10	410	186
GR6256	⅝	6	15.8	1.8	4	5	600	272
GR6258 (0.620 – 0.630)	⅝	8	15.8	2.4	4	5	800	363
GR6250 (0.555 – 0.565)	⅝	10	15.8	3.0	4	5	1,000	454
GR6260 (0.620 – 0.630)	⅝	10	15.8	3.0	4	5	1,000	454
GR7506	¾	6	17.3	1.8	4	5	700	318
GR7508 (0.745 – 0.755)	¾	8	17.3	2.4	4	5	1,200	545
GR7510 (0.745 – 0.755)	¾	10	17.3	3.0	4	5	1,500	681



Copper-bonded steel ground rods

- All EZGround ground rods have a heavy uniform covering of electrolytic copper bonded to a rigid steel core
- Copper ions are forced electrically to join with the steel core, establishing a corrosion-resistant bond between the copper and the steel

Cat. no.	Trade size		Rod size (nominal diameter x length)		Plating thickness (mils)	Standard packaging	Weight per 100	
	in.	ft.	mm	m			lb	kg
5005	½	5	12.7	1.5	10	10	305	138
5006	½	6	12.7	1.8	10	5	370	168
5008	½	8	12.7	2.4	10	5	545	247
5010	½	10	12.7	3.0	10	5	611	277
6256	⅝	6	15.8	1.8	10	5	508	230
6258*	⅝	8	15.8	2.4	10	5	678	308
6260*	⅝	10	15.8	3.0	10	5	847	384
7508*	¾	8	17.3	2.4	10	5	992	450
7510*	¾	10	17.3	3.0	10	5	1,240	462
1010*	1	10	25.4	3.0	10	1	2,248	1,020

* Ground rods are UL listed (425H), except for regular rods shorter than 8 ft. or less than ½ in. cULus lists rods ½ in. and larger, 10 ft. and longer.



Knurling die for 14- and 15-ton tools

Cat. no.	Description
15508SS	For ⅝ in. and ¾ in. ground rods

Used to knurl ground rods in order to increase the pullout value of the compression connection by as much as 20%. Use hand knurling tool cat. no. 240-31565-94 for all ground rods.

Ground rods



Sectional-type ground rods

- Sectional-type ground rods have the same high quality as regular copper-bonded steel ground rods and are threaded top and bottom

Cat. no.	Trade size		Rod size (nominal diameter x length)		Plating thickness (mils)	Thread size	Standard packaging	Weight per 100	
	in.	ft.	mm	m				lb	kg
5008LS	½	8	12.7	2.4	10	¼-12	5	546	248
5010LS	½	10	12.7	3.0	10	¼-12	5	682	309
6258S	⅝	8	15.8	2.4	10 mils	⅝-11	5	670	308
6260S	⅝	10	15.8	3.0	10 mils	⅝-11	5	837	384
7506S	¾	6	17.3	1.8	5 mils	¾-10	5	774	160
7508S	¾	8	17.3	2.4	10 mils	¾-10	5	992	450
7510S	¾	10	17.3	3.0	10 mils	¾-10	5	1,040	562
1010S	1	10	25.4	3.0	10 mils	8-1	1	2,248	1,020

cULus lists rods ½ in. and larger, 10 ft. and longer.



Couplings

- Threaded couplings are made of high-strength, corrosion-resistant alloy. Streamlined design reduces driving friction. Couplings are tapped for use on all standard threaded sectional rods.



Cat. no.	Rod size diameter (in.)	Thread size (UNS)	Standard packaging	Weight per 100 (lb)
50LC	½	¼ po - 12	25	17
60C	⅝	⅝ po - 11	25	25
70C	¾	¾ po - 10	25	38
80C	1	1 - 8	10	75



Driving studs

- Driving studs of high-strength steel
- May be used with all standard threaded couplings



Cat. no.	Rod size diameter (in.)	Thread size (UNS)	Standard packaging	Weight per 100 (lb)
50LDS*	½	9/16 in. - 12	10	16
60DS*+	⅝	5/8 in. - 11	25	23
80DS	1	1 - 8	10	75

* UL Listed
+ CSA Certified

Ground rods



Threadless couplings and driving caps for standard copper bonded ground rods

Threadless couplings

- For joining non-threaded, sectional, copper-bonded, steel ground rods
- Coupling is manufactured of a high-strength, corrosion-resistant silicon bronze

Threadless driving caps

- Prevent “mushrooming” of ground rod while driving to ensure proper fit of coupling
- Driving cap is manufactured of high-strength, hardened steel



Cat. no.	Size (in.)	Dimensions (in.)		Standard packaging	Weight per 100 (lb)
		Length	Diameter		
Threadless couplings					
50CNT	½	3.0	0.78	25	34
60CNT2	⅝	2.5	0.69	25	34
70CNT	¾	3.0	0.97	25	31
Driving caps					
60DSNT *	⅝	4.0	0.88	10	43

* UL not applicable

Ground rod drivers



Photo includes ground rod driver and insert.

For installing ground rods, there's no safer, simpler or more effective tool than the ABB ground rod driver. It can be used on all types of ground rods including copper-bonded, galvanized and stainless steel.

Integral inserts prevent the driver from slipping off the rod near ground level. The inserts are 5/8 in. and 3/4 in., and are interchangeable with the standard driver body. The convenient retaining collar holds the insert in the tool when not in use. ABB ground rod drivers have a heavy-duty steel construction that allows maximum force for driving ground rods, while the efficient design ensures that minimal lifting force is required. The ground rod end is designed for high-impact applications to ensure quality connections.

- Unique design allows installation of 10-foot rods from ground level
- Heavy-duty steel construction
- Ergonomic grip provides ease and comfort with increased safety
- Complete with interchangeable parts that are range-taking for different diameter ground rods
- Two interchangeable inserts allow the same tool to be used with all sizes of rods
- Completely self-contained and easy to store

Ground rod drivers

Cat. no.	Description	Weight (lb)	Maximum rod diameter (in.)	Std. pkg.
TBRD58	5 ft. Ground rod driver with 5/8 in. insert	25	0.63	1
TBRD34	5 ft. Ground rod driver with 3/4 in. insert		0.75	1
TBS58	Replacement 5/8 in. insert	4	0.63	1
TBS34	Replacement 3/4 in. insert		0.75	1

Diagrams

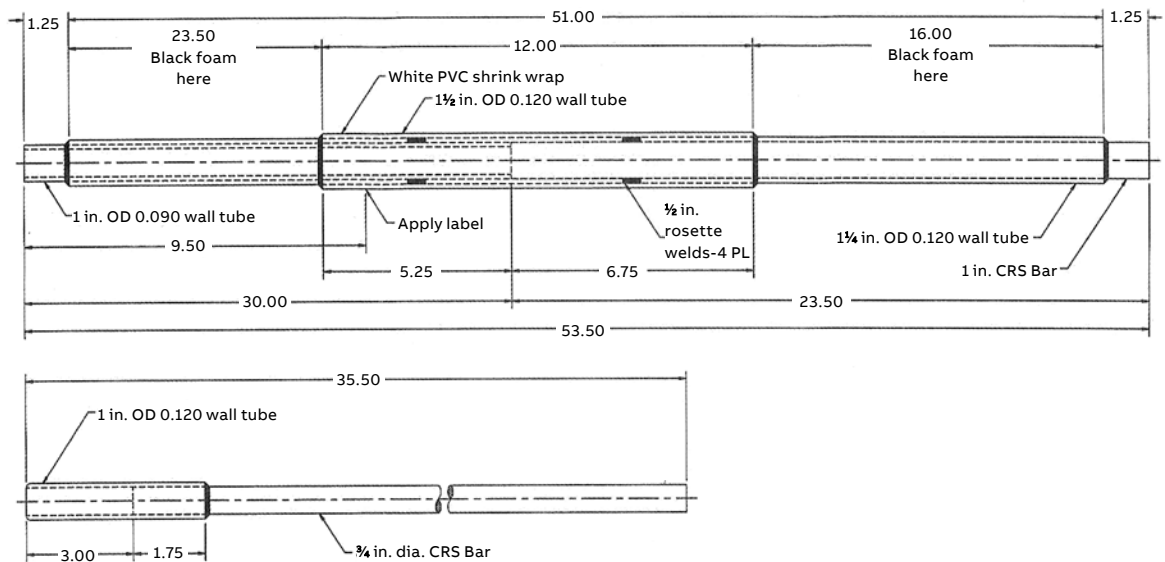

Flexible braids



Flexible braid for grounding, bonding and continuous current applications

- Tin-plated copper braids and ferrules for high conductivity and corrosion resistance
- Flexible copper braids for use in substation and grounding applications
- Flexible braids allow for linear expansion, equipment vibration and offset connections



Cat. no.	Circular mils	Wire Equivalent	Bolt hole (in.)	No. of braids by ferrule	Dimensions (in.)			
					(T) Thickness	(C) Width	(D) Ferrule length	(E) Distance ctr. to ctr.
FB12-1*	24,000	6 AWG	3/4	1	0.140	0.625	0.750	-
FBC12-1*	48,000	3 AWG	3/8	1	0.148	1.000	1.300	-
FBD12-1*	76,800	1 AWG	3/8	1	0.200	1.000	1.300	-
FBD12*	76,800	1 AWG	3/8	1	0.200	1.000	2.500	1.25
FB2D12-1*	153,600	154 kcmil	3/8	2	0.250	1.250	1.500	-
FB2D12*	153,600	154 kcmil	3/8	2	0.250	1.250	2.500	1.25
FB3D12-1*	230,400	231 kcmil	3/8	3	0.350	1.250	1.500	-
FB3D12*	230,400	231 kcmil	3/8	3	0.350	1.250	2.500	1.25
FBXD12-1*	105,600	1/0 AWG	1/2	1	0.250	1.250	1.500	-
FBXD12*	105,600	1/0 AWG	1/2	1	0.250	1.250	2.500	1.25
FB2XD12-1*	211,200	4/0 AWG	1/2	2	0.350	1.250	1.500	-
FB2XD12*	211,200	4/0 AWG	1/2	2	0.350	1.250	2.500	1.25
FB3XD12-1*	315,800	316 kcmil	1/2	3	0.400	1.250	1.500	-
FB3XD12*	315,800	316 kcmil	1/2	3	0.400	1.250	2.500	1.25
FBE12-1*	168,000	3/0 AWG	1/2	1	0.500	1.250	2.500	-
FBE12**	168,000	3/0 AWG	1/2	1	0.250	1.250	3.500	1.75
FB2E12-1*	336,000	350 kcmil	1/2	1	0.500	1.250	2.500	-
FB2E12*	336,000	350 kcmil	1/2	2	0.500	1.250	3.500	1.75
FB3E12	504,000	500 kcmil	1/2	3	0.750	1.250	3.500	1.75
FB4E12	672,000	672 kcmil	1/2	4	1.00	1.25	3.500	1.75
FBF12	230 400	231 kcmil	1/2	1	0.300	1.500	3.500	1.75
FB2F12	460,800	462 kcmil	1/2	2	0.450	1.500	3.500	1.75
FB3F12	691,200	696 kcmil	1/2	3	0.600	1.625	3.500	1.75
FB4F12	921,600	928 kcmil	1/2	4	0.750	1.625	3.500	1.75
FBG12	307,200	308 kcmil	1/2	1	0.380	1.500	3.500	1.75
FB2G12	614,400	616 kcmil	1/2	2	0.630	1.625	3.500	1.75
FB3G12	921,600	928 kcmil	1/2	3	0.850	1.625	3.500	1.75
FB4G12	1,228,800	1,250 kcmil	1/2	4	1.000	1.880	3.500	1.75

Diagrams

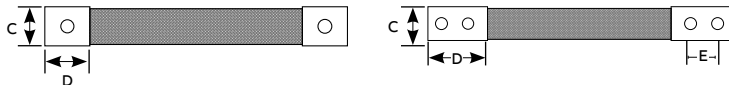

*UL listed 467/486 and CSA certified C22.2 No. 41 as grounding and bonding equipment. Standard lengths offered in 6, 12, 18, 24, 30 and 36 inches (end to end). Change the 12 in the above catalogue numbers to the desired length. (-1) indicates 1 bolt hole per ferrule. For custom flexible braids, contact your ABB regional sales office.

Flat braided tinned copper cable *

Cat. no.	Circular mils	Thickness (in.)	Width (in.)
FBBRL	24,000	0.140	0.625
FBCRL	48,000	0.418	1.000
FBDRL	76,800	0.200	1.000
FBXDRL	105,600	0.250	1.250

Cable only, sold in roll. Minimum quantities apply to some products; contact your representative for more information.

Minimum size conductors for bonding raceways and equipment

Rating or setting of overcurrent device in circuit ahead of equipment, conduit, etc. Not exceeding — Amperes	Copper wire circular mils
200	26,240
300	41,740
400	52,620
500	66,360
600	83,690
800	105,600
1,000	133,100
1,200	167,800
1,600	211,600
2,000	250,000
2,500	350,000
3,000	400,000
4,000	500,000
5,000	700,000
6,000	800,000

Based on table 16 CEC.

Minimum size of bare copper grounding conductor

Maximum available short circuit current amperes	Maximum fault duration with exothermic weld, compression or bolted joint	
	0.5 seconds circular mils	1.0 second circular mils
5,000	26,240	47,740
10,000	52,620	83,690
15,000	83,690	105,600
20,000	105,600	167,800
25,000	133,100	211,600
30,000	167,800	211,600
35,000	211,600	250,000
40,000	211,600	300,000
50,000	250,000	350,000
60,000	300,000	500,000
70,000	350,000	600,000
80,000	400,000	600,000
90,000	500,000	700,000
100,000	500,000	700,000

Based on table 51 CEC. Size calculated in accordance with IEEE No.80.

Exothermic welding system

Earth points

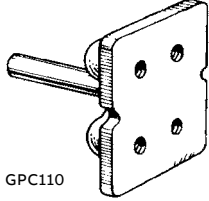

GPC110

Four-hole earth points

Cat. no.	A Hole size (in.)	B (in.)	C (in.)	D (in.)	E (in.)	F (in.)
GPC110	4 x 5/16 UNC x 5/16	27/64	2	3	2 1/2	1 13/32
GPC111	As GPC110 with a pre-welded 20 in. long tail of 2/0 AWG PVC-insulated cable					

Diagrams

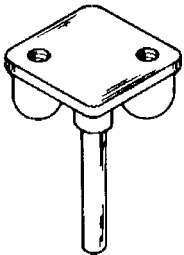
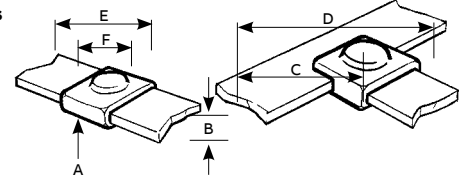

GPC125

Two-hole earth points Complete with front plate

Cat. no.	Conductor type	B (in. dia.)	C (in.)	D (in.)	E (in.)	F (in.)
GPC115	1 in. x 1/8 in. tape or 2/0 AWG cable	27/64	2	3 1/8	2 3/16	1 3/4
GPC116	As GPC115 with a pre-welded 20 in. long tail of 2/0 AWG PVC-insulated cable					
GPC120	1 in. x 1/8 in. tape or 5/16 in. dia. solid	27/64	2	3 1/8	2 3/16	1 3/4
GPC121	As PC120 with a pre-welded 20 in. long tail of 2/0 AWG PVC-insulated cable					

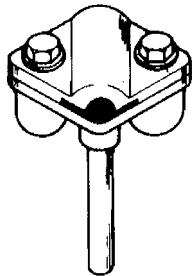

GPC115 - GPC120

Two-hole earth points Without front plate

Cat. no.	Conductor type	B (in. dia.)	C (in.)	D (in.)	E (in.)	F (in.)
GPC125	2 x 5/16 UNC x 1/2	27/64	2	3 1/8	2 3/16	1 3/4
GPC126	As PC125 with a pre-welded 20 in. long tail of 2/0 AWG PVC-insulated cable					

Diagrams

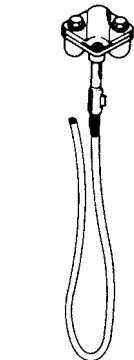
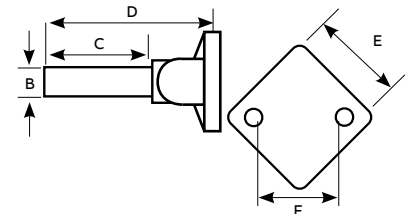

GPC116 - GPC121

Exothermic welding system

Earth points

One-hole earth points

Cat. no.	A hole size	B (in. dia.)	C (in.)	D (in.)	E (in.)
GPC100	1 x $\frac{5}{16}$ UNC x $\frac{5}{8}$	$\frac{27}{64}$	$2\frac{3}{16}$	$3\frac{3}{8}$	$1\frac{3}{8}$
GPC101	1 x $\frac{3}{8}$ UNC x $\frac{5}{8}$	$\frac{27}{64}$	$2\frac{3}{16}$	$3\frac{3}{8}$	$1\frac{3}{8}$
GPC105	As PC100 with a pre-welded 20 in. long tail of 2/0 AWG PVC-insulated cable				
GPC106	As PC101 with a pre-welded 20 in. long tail of 2/0 AWG PVC-insulated cable				

Diagrams

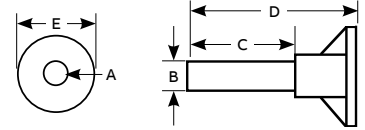

GRX005

Static earth receptacle

Cat. no.	B (in. dia.)	C (in.)	D (in.)	E (in.)
GRX005	$\frac{27}{64}$	1½	$3\frac{3}{8}$	$2\frac{11}{16}$

Diagram

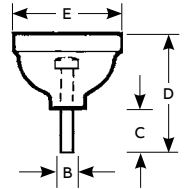

Exothermic welding system

CCI cable to cable

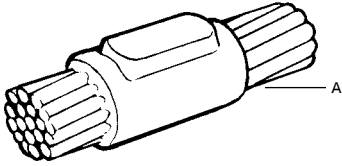

- Stranded conductor
- Solid circular conductor

—
CCI

Cat. no.	Wire size (A) (AWG or kcmil)	Welding powder size	Handle clamp type	Std. qty.
CC1-3-#3	#3	32BKB	HCPK3	1
CC1-3-#2	#2	32BKB	HCPK3	1
CC1-3-#2S	#2 solid	32BKB	HCPK3	1
CC1-3-#1	#1	32BKB	HCPK3	1
CC1-3-#1S	#1 solid	32BKB	HCPK3	1
CC1-4-1/0	1/0	45BKB	HCPK4	1
CC1-4-1/0S	1/0 solid	45BKB	HCPK4	1
CC1-4-2/0	2/0	65BKB	HCPK4	1
CC1-4-3/0	3/0	90BKB	HCPK4	1
CC1-4-4/0	4/0	90BKB	HCPK4	1
CC1-4-4/0S	4/0 solid	90BKB	HCPK4	1
CC1-4-250K	250	115BKB	HCPK4	1
CC1-4-300K	300	115BKB	HCPK4	1
CC1-4-350K	350	150BKB	HCPK4	1
CC1-4-500K	500	200BKB	HCPK4	1
CC1-5-750K	750	2 X 150BKB	HCPK5	1
CC1-5-1000K	1,000	2 X 200BKB	HCPK5	1

Exothermic welding system

CC2 cable to cable

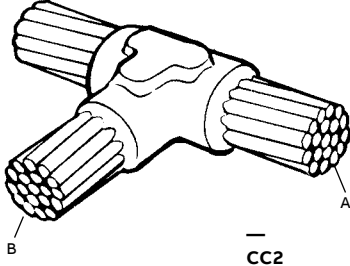

- Stranded conductor
- Solid circular conductor

Cat. no.	Wire size (AWG or kcmil)		Welding powder size	Handle clamp type	Std. qty.
	A	B			
CC2-4-#4#4	4	4	32BKB	HCPK4	1
CC2-4-#2S#2	#2 solid	#2	45BKB	HCPK4	1
CC2-4-#2S#2S	#2 solid	#2 solid	45BKB	HCPK4	1
CC2-4-#2S#4	#2 solid	#4	45BKB	HCPK4	1
CC2-4-#2#2	#2	#2	45BKB	HCPK4	1
CC2-4-#2#2S	#2	#2 solid	45BKB	HCPK4	1
CC2-4-#2#4	#2	#4	45BKB	HCPK4	1
CC2-4-#1#1	#1	#1	45BKB	HCPK4	1
CC2-4-#1#2	#1	#2	45BKB	HCPK4	1
CC2-4-#1#2S	#1	#2 solid	45BKB	HCPK4	1
CC2-4-#1#4	#1	#4	45BKB	HCPK4	1
CC2-4-1/01/0	1/0	1/0	90BKB	HCPK4	1
CC2-4-1/0#1	1/0	#1	45BKB	HCPK4	1
CC2-4-1/0#2	1/0	#2	45BKB	HCPK4	1
CC2-4-1/0#2S	1/0	#2 solid	45BKB	HCPK4	1
CC2-4-1/0#4	1/0	#4	45BKB	HCPK4	1
CC2-4-2/02/0	2/0	2/0	90BKB	HCPK4	1
CC2-4-2/01/0	2/0	1/0	90BKB	HCPK4	1
CC2-4-2/0#1	2/0	#1	45BKB	HCPK4	1
CC2-4-2/0#2	2/0	#2	45BKB	HCPK4	1
CC2-4-2/0#2S	2/0	2 solid	45BKB	HCPK4	1
CC2-4-2/0#4	2/0	#4	45BKB	HCPK4	1
CC2-4-3/03/0	3/0	3/0	115BKB	HCPK4	1
CC2-4-3/02/0	3/0	2/0	90BKB	HCPK4	1
CC2-4-3/01/0	3/0	1/0	90BKB	HCPK4	1
CC2-4-3/0#1	3/0	#1	45BKB	HCPK4	1

Cat. no.	Wire size (AWG or kcmil)		Welding powder size	Handle clamp type	Std. qty.
	A	B			
CC2-4-3/0#2	3/0	#2	45BKB	HCPK4	1
CC2-4-3/0#2S	3/0	#2 solid	45BKB	HCPK4	1
CC2-4-3/0#4	3/0	#4	45BKB	HCPK4	1
CC2-4-4/04/0	4/0	4/0	150BKB	HCPK4	1
CC2-4-4/03/0	4/0	3/0	115BKB	HCPK4	1
CC2-4-4/02/0	4/0	2/0	90BKB	HCPK4	1
CC2-4-4/01/0	4/0	1/0	90BKB	HCPK4	1
CC2-4-4/0#1	4/0	#1	90BKB	HCPK4	1
CC2-4-4/0#2	4/0	#2	90BKB	HCPK4	1
CC2-4-4/0#2S	4/0	#2 solid	90BKB	HCPK4	1
CC2-4-4/0#4	4/0	#4	90BKB	HCPK4	1
CC2-4-250K250K	250	250	150BKB	HCPK4	1
CC2-4-250K4/0	250	4/0	150BKB	HCPK4	1
CC2-4-250K4/0	250	3/0	150BKB	HCPK4	1
CC2-4-250K2/0	250	2/0	90BKB	HCPK4	1
CC2-4-250K1/0	250	1/0	90BKB	HCPK4	1
CC2-4-250K#1	250	#1	90BKB	HCPK4	1
CC2-4-250K#2	250	#2	90BKB	HCPK4	1
CC2-4-250K#2S	250	#2 solid	90BKB	HCPK4	1
CC2-4-250K#4	250	#4	90BKB	HCPK4	1
CC2-4-300K300K	300	300	200BKB	HCPK4	1
CC2-4-300K250K	300	250	150BKB	HCPK4	1
CC2-4-300K4/0	300	4/0	150BKB	HCPK4	1
CC2-4-300K3/0	300	3/0	150BKB	HCPK4	1
CC2-4-300K2/0	300	2/0	90BKB	HCPK4	1
CC2-4-300K1/0	300	1/0	90BKB	HCPK4	1

Exothermic welding system

CC2 cable to cable

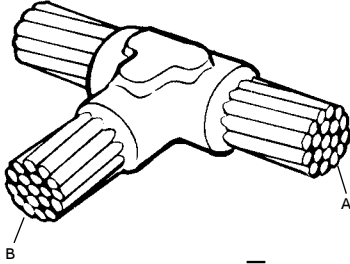

- Stranded conductor
- Solid circular conductor

CC2 (cont'd)

Cat. no.	Wire size (AWG or kcmil)		Welding powder size	Handle clamp type	Std. qty.
	A	B			
CC2-4-300K#2	300	#2	90BKB	HCPK4	1
CC2-4-300K#2S	300	#2 solid	90BKB	HCPK4	1
CC2-4-300K#4	300	#4	90BKB	HCPK4	1
CC2-4-350K350K	350	350	200BKB	HCPK4	1
CC2-4-350K300K	350	300	200BKB	HCPK4	1
CC2-4-350K250K	350	250	200BKB	HCPK4	1
CC2-4-350K4/0	350	4/0	150BKB	HCPK4	1
CC2-4-350K3/0	350	3/0	150BKB	HCPK4	1
CC2-4-350K2/0	350	2/0	90BKB	HCPK4	1
CC2-4-350K1/0	350	1/0	90BKB	HCPK4	1
CC2-4-350K#1	350	#1	90BKB	HCPK4	1
CC2-4-350K#2	350	#2	90BKB	HCPK4	1
CC2-4-350K#4	350	#4	90BKB	HCPK4	1
CC2-4-500K500K	500	500	2 X 150BKB	HCPK4	1
CC2-4-500K350K	500	350	200BKB	HCPK4	1
CC2-4-500K300K	500	300	200BKB	HCPK4	1
CC2-4-500K250K	500	250	200BKB	HCPK4	1
CC2-4-500K4/0	500	4/0	150BKB	HCPK4	1
CC2-4-500K2/0	500	2/0	90BKB	HCPK4	1
CC2-4-500K1/0	500	1/0	90BKB	HCPK4	1
CC2-4-500K#1	500	#1	90BKB	HCPK4	1
CC2-4-500K#2	500	#2	90BKB	HCPK4	1
CC2-4-500K#4	500	#4	90BKB	HCPK4	1
CC2-5-750K750K	750	750	2 X 250BKB	HCPK5	1
CC2-5-750K500K	750	500	2 X 250BKB	HCPK5	1
CC2-4-750K350K	750	350	250BKB	HCPK4	1

Cat. no.	Wire size (AWG or kcmil)		Welding powder size	Handle clamp type	Std. qty.
	A	B			
CC2-4-750K300K	750	300	200BKB	HCPK4	1
CC2-4-750K250	750	250	200BKB	HCPK4	1
CC2-4-750K4/0	750	4/0	150BKB	HCPK4	1
CC2-4-750K2/0	750	2/0	150BKB	HCPK4	1
CC2-4-750K1/0	750	1/0	150BKB	HCPK4	1
CC2-5-1000K1000K	1,000	1,000	2 X 250BKB	HCPK5	1
CC2-5-1000K750K	1,000	750	2 X 250BKB	HCPK5	1
CC2-5-1000K500K	1,000	500	2 X 200BKB	HCPK5	1
CC2-4-1000K350K	1,000	350	250BKB	HCPK4	1
CC2-4-1000K300K	1,000	300	200BKB	HCPK4	1
CC2-4-1000K250K	1,000	250	200BKB	HCPK4	1
CC2-4-1000K4/0	1,000	4/0	150BKB	HCPK4	1
CC2-4-1000K2/0	1,000	2/0	150BKB	HCPK4	1
CC2-4-1000K1/0	1,000	1/0	150BKB	HCPK4	1

Exothermic welding system

CC4 cable to cable

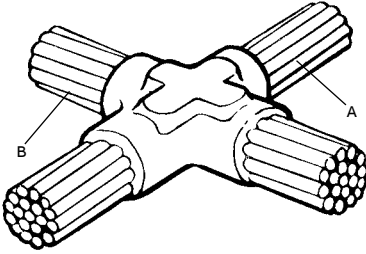

CC4

- Stranded conductor
- Solid circular conductor

Cat. no.	Wire size (AWG or kcmil)		Welding powder size	Handle clamp type	Std. qty.
	A	B			
CC4-4-#4#4	#4	#4	45BKB	HCPK4	1
CC4-4-#2#2	#2	#2	65BKB	HCPK4	1
CC4-4-#2#4	#2	#4	65BKB	HCPK4	1
CC4-4-#2S#2S	2 solid	2 solid	2 massif	HCPK4	1
CC4-4-#1#1	#1	#1	65BKB	HCPK4	1
CC4-4-#1#2	#1	#2	65BKB	HCPK4	1
CC4-4-#1#4	#1	#4	65BKB	HCPK4	1
CC4-4-1/01/0	1/0	1/0	90BKB	HCPK4	1
CC4-4-1/0#1	1/0	#1	90BKB	HCPK4	1
CC4-4-1/0#2	1/0	#2	90BKB	HCPK4	1
CC4-4-1/0#4	1/0	#4	90BKB	HCPK4	1
CC4-4-2/02/0	2/0	2/0	115BKB	HCPK4	1
CC4-42/01/0	2/0	1/0	115BKB	HCPK4	1
CC4-4-2/0#1	2/0	#1	115BKB	HCPK4	1
CC4-4-2/0#2	2/0	#2	115BKB	HCPK4	1
CC4-4-3/03/0	3/0	3/0	115BKB	HCPK4	1
CC4-4-3/02/0	3/0	2/0	150BKB	HCPK4	1
CC4-4-3/01/0	3/0	1/0	115BKB	HCPK4	1
CC4-4-3/0#1	3/0	#1	115BKB	HCPK4	1
CC4-4-3/0#2	3/0	#2	115BKB	HCPK4	1
CC4-4-4/04/0	4/0	4/0	200BKB	HCPK4	1
CC4-4-4/03/0	4/0	3/0	200BKB	HCPK4	1
CC4-4-4/02/0	4/0	2/0	150BKB	HCPK4	1
CC4-4-4/01/0	4/0	1/0	150BKB	HCPK4	1
CC4-4-4/0#1	4/0	#1	115BKB	HCPK4	1
CC4-4-4/0#2	4/0	#2	115BKB	HCPK4	1
CC4-4-250K250K	250	250	200BKB	HCPK4	1
CC4-4-250K4/0	250	4/0	200BKB	HCPK4	1
CC4-4-250K3/0	250	3/0	200BKB	HCPK4	1
CC4-4-250K2/0	250	2/0	150BKB	HCPK4	1
CC4-4-250K1/0	250	1/0	150BKB	HCPK4	1
CC4-4-250K#1	250	#1	115BKB	HCPK4	1
CC4-4-250K#2	250	#2	115BKB	HCPK4	1

Cat. no.	Wire size (AWG or kcmil)		Welding powder size	Handle clamp type	Std. qty.
	A	B			
CC4-4-300K300K	300	300	250BKB	HCPK4	1
CC4-4-300K250K	300	250	250BKB	HCPK4	1
CC4-4-300K4/0	300	4/0	200BKB	HCPK4	1
CC4-4-300K3/0	300	3/0	200BKB	HCPK4	1
CC4-4-300K2/0	300	2/0	150BKB	HCPK4	1
CC4-4-300K1/0	300	1/0	150BKB	HCPK4	1
CC4-4300K#1	300	#1	115BKB	HCPK4	1
CC4-4-300K#2	300	#2	115BKB	HCPK4	1
CC4-4-350K350K	350	350	250BKB	HCPK4	1
CC4-4-350K300K	350	300	250BKB	HCPK4	1
CC4-4-4350K250K	350	250	250BKB	HCPK4	1
CC4-4-350K4/0	350	4/0	200BKB	HCPK4	1
CC4-4-350K3/0	350	3/0	200BKB	HCPK4	1
CC4-350K2/0	350	2/0	200BKB	HCPK4	1
CC4-4-350K1/0	350	1/0	200BKB	HCPK4	1
CC4-4-350K#1	350	#1	150BKB	HCPK4	1
CC4-4-350K#2	350	#2	150BKB	HCPK4	1
CC4-5-500K500K	500	500	2 X 250BKB	HCPK5	1
CC4-5-500K350K	500	350	2 X 200BKB	HCPK5	1
CC4-5-500K300K	500	300	2 X 200BKB	HCPK5	1
CC4-5-500K250K	500	250	2 X 150BKB	HCPK5	1
CC4-5-500K4/0	500	4/0	2 X 150BKB	HCPK5	1
CC4-5-500K3/0	500	3/0	2 X 150BKB	HCPK5	1
CC4-4-500K2/0	500	2/0	250BKB	HCPK5	1
CC4-4-500K1/0	500	1/0	250BKB	HCPK5	14

Exothermic welding system

CC6 cable to cable

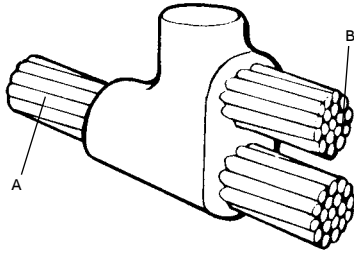

CC6

- Stranded conductor
- Solid circular conductor

Cat. no.	Wire size (AWG or kcmil)		Welding powder size	Handle clamp type	Std. qty.
	A	B			
CC6-4-#4#4	#4	#4	45BKB	HCPK4	1
CC6-4-#2#2	#2	#2	65BKB	HCPK4	1
CC6-4-#2#4	#2	#4	65BKB	HCPK4	1
CC6-4-#2S#2S	2 solid	2 solid	65BKB	HCPK4	1
CC6-4-#1#1	#1	#1	65BKB	HCPK4	1
CC6-4-#1#2	#1	#2	65BKB	HCPK4	1
CC6-4-#1#4	#1	#4	65BKB	HCPK4	1
CC6-4-1/01/0	1/0	1/0	90BKB	HCPK4	1
CC6-4-1/0#1	1/0	#1	90BKB	HCPK4	1
CC6-4-1/0#2	1/0	#2	90BKB	HCPK4	1
CC6-4-1/0#4	1/0	#4	90BKB	HCPK4	1
CC6-4-2/02/0	2/0	2/0	115BKB	HCPK4	1
CC6-4-2/01/0	2/0	1/0	115BKB	HCPK4	1
CC6-4-2/0#1	2/0	#1	115BKB	HCPK4	1
CC6-4-2/0#2	2/0	#2	115BKB	HCPK4	1
CC6-4-3/03/0	3/0	3/0	115BKB	HCPK4	1
CC6-4-3/02/0	3/0	2/0	150BKB	HCPK4	1
CC6-4-3/01/0	3/0	1/0	115BKB	HCPK4	1
CC6-4-3/0#1	3/0	#1	115BKB	HCPK4	1
CC6-4-3/0#2	3/0	#2	115BKB	HCPK4	1
CC6-4-4/04/0	4/0	4/0	200BKB	HCPK4	1
CC6-4-4/03/0	4/0	3/0	200BKB	HCPK4	1
CC6-4-4/02/0	4/0	2/0	150BKB	HCPK4	1
CC6-4-4/01/0	4/0	1/0	150BKB	HCPK4	1
CC6-4-4/0#1	4/0	#1	115BKB	HCPK4	1
CC6-4-4/0#2	4/0	#2	115BKB	HCPK4	1

Cat. no.	Wire size (AWG or kcmil)		Welding powder size	Handle clamp type	Std. qty.
	A	B			
CC6-4-250K250K	250	250	200BKB	HCPK4	1
CC6-4-250K4/0	250	4/0	200BKB	HCPK4	1
CC6-4-250K3/0	250	3/0	200BKB	HCPK4	1
CC6-4-250K2/0	250	2/0	150BKB	HCPK4	1
CC6-4-250K1/0	250	1/0	150BKB	HCPK4	1
CC6-4-250K#1	250	#1	115BKB	HCPK4	1
CC6-4-250K#2	250	#2	115BKB	HCPK4	1
CC6-4-300K300K	300	300	250BKB	HCPK4	1
CC6-4-300K250K	300	250	250BKB	HCPK4	1
CC6-4-300K4/0	300	4/0	200BKB	HCPK4	1
CC6-4-300K3/0	300	3/0	200BKB	HCPK4	1
CC6-4-300K2/0	300	2/0	150BKB	HCPK4	1
CC6-4-300K1/0	300	1/0	150BKB	HCPK4	1
CC6-4-300K#1	300	#1	115BKB	HCPK4	1
CC6-4-300K#2	300	#2	115BKB	HCPK4	1
CC6-4-350K350K	350	350	250BKB	HCPK4	1
CC6-4-350K300K	350	300	250BKB	HCPK4	1
CC6-4-4350K250K	350	250	250BKB	HCPK4	1
CC6-4-350K4/0	350	4/0	200BKB	HCPK4	1
CC6-4-350K3/0	350	3/0	200BKB	HCPK4	1
CC6-4-350K2/0	350	2/0	200BKB	HCPK4	1

Exothermic welding system

CC7 cable to cable

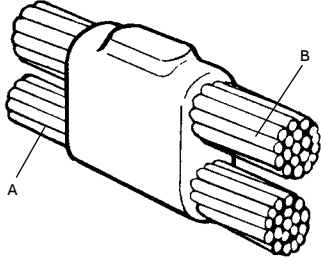

- Stranded conductor
- Solid circular conductor

CC7

Cat. no.	Wire size (AWG or kcmil)		Welding powder size	Handle clamp type	Sleeve	Std. qty.
	A	B				
CC7-4-#4#4	#4	#4	32BKB	HCPK4	-	1
CC7-4-#4#6	#4	#6	32BKB	HCPK4	2 X Sleeve#6	1
CC7-4-#4#6S	#4	#6 solid	32BKB	HCPK4	2 X Sleeve#6S	1
CC7-4-#4#8	#4	#8	32BKB	HCPK4	2 X Sleeve#8	1
CC7-4-#2S#2	#2 solid	#2	65BKB	HCPK4	-	1
CC7-4-#2S#2S	#2 solid	#2 solid	65BKB	HCPK4	-	1
CC7-4-#2S#4	#2 solid	#4	65BKB	HCPK4	-	1
CC7-4-#2S#6	#2 solid	#6	45BKB	HCPK4	2 X Sleeve#6	1
CC7-4-#2S#6S	#2 solid	#6 solid	45BKB	HCPK4	2 X Sleeve#6S	1
CC7-4-#2S#8	#2 solid	#8	45BKB	HCPK4	2 X Sleeve#8	1
CC7-4-#2S#8S	#2 solid	#8 solid	8 solid	HCPK4	2 X Sleeve#8S	1
CC7-4-#2#2	#2	#2	65BKB	HCPK4	-	1
CC7-4-#2#4	#2	#4	65BKB	HCPK4	-	1
CC7-4-#2#6	#2	#6	45BKB	HCPK4	2 X Sleeve#6	1
CC7-4-#2#6S	#2	#6 solid	45BKB	HCPK4	2 X Sleeve#6S	1
CC7-4-#2#8	#2	#8	45BKB	HCPK4	2 X Sleeve#8	1
CC7-4-#2#8S	#2	#8 solid	45BKB	HCPK4	2 X Sleeve#8S	1
CC7-4-#1S#1	#1 solid	#1	65BKB	HCPK4	-	1
CC7-4-#1S#2	#1 solid	#2	65BKB	HCPK4	-	1
CC7-4-#1S#2S	#1 solid	#2 solid	65BKB	HCPK4	-	1
CC7-4-#1S#4	#1 solid	#4	65BKB	HCPK4	-	1
CC7-4-#1S#6	#1 solid	#6	65BKB	HCPK4	2 X Sleeve#6	1
CC7-4-#1S#6S	#1 solid	#6 solid	65BKB	HCPK4	2 X Sleeve#6S	1
CC7-4-#1S#8	#1 solid	#8	45BKB	HCPK4	2 X Sleeve#8	1
CC7-4-#1S#8S	#1 solid	#8 solid	45BKB	HCPK4	2 X Sleeve#8S	1
CC7-4-#1#1	#1	#1	65BKB	HCPK4	-	1
CC7-4-#1#1S	#1	#1 solid	65BKB	HCPK4	-	1
CC7-4-#1#2	#1	#2	65BKB	HCPK4	-	1
CC7-4-#1#2S	#1	#2 solid	65BKB	HCPK4	-	1
CC7-4-#1#4	#1	#4	65BKB	HCPK4	-	1
CC7-4-#1#6	#1	#6	65BKB	HCPK4	2 X Sleeve#6	1
CC7-4-#1#6S	#1	#6 solid	65BKB	HCPK4	2 X Sleeve#6S	1
CC7-4-#1#8	#1	#8	45BKB	HCPK4	2 X Sleeve#8	1
CC7-4-#1#8S	#1	#8 solid	45BKB	HCPK4	2 X Sleeve#8S	1
CC7-4-1/0S1/0	1/0 solid	1/0	90BKB	HCPK4	-	1
CC7-4-1/0S1/0S	1/0 solid	1/0 solid	90BKB	HCPK4	-	1
CC7-4-1/0S#1	1/0 solid	#1	65BKB	HCPK4	-	1
CC7-4-1/0S#1S	1/0 solid	#1 solid	65BKB	HCPK4	-	1
CC7-4-1/0S#2	1/0 solid	#2	65BKB	HCPK4	-	1
CC7-4-1/0S#2S	1/0 solid	#2 solid	65BKB	HCPK4	-	1
CC7-4-1/0S#4	1/0 solid	#4	65BKB	HCPK4	-	1
CC7-4-1/0S#6	1/0 solid	#6	65BKB	HCPK4	2 X Sleeve#6	1
CC7-4-1/0S#6S	1/0 solid	#6 solid	65BKB	HCPK4	2 X Sleeve#6S	1
CC7-4-1/0S#8	1/0 solid	#8	65BKB	HCPK4	2 X Sleeve#8	1
CC7-4-1/0S#8S	1/0 solid	#8 solid	65BKB	HCPK4	2 X Sleeve#8S	1
CC7-4-1/01/0	1/0	1/0	90BKB	HCPK4	-	1
CC7-4-1/01/0S	1/0	1/0 solid	90BKB	HCPK4	-	1

Exothermic welding system

CC7 cable to cable

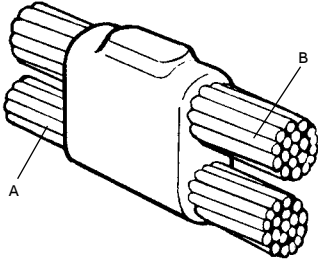

- Stranded conductor
- Solid circular conductor

CC7 (cont'd)

Cat. no.	Wire size (AWG or kcmil)		Welding powder size	Handle clamp type	Sleeve	Std. qty.
	A	B				
CC7-4-1/0#1	1/0	#1	65BKB	HCPK4	-	1
CC7-4-1/0#1S	1/0	#1 solid	65BKB	HCPK4	-	1
CC7-4-1/0#2	1/0	#2	65BKB	HCPK4	-	1
CC7-4-1/0#2S	1/0	#2 solid	65BKB	HCPK4	-	1
CC7-4-1/0#4	1/0	#4	65BKB	HCPK4	-	1
CC7-4-1/0#6	1/0	#6	65BKB	HCPK4	2 X Sleeve#6	1
CC7-4-1/0#6S	1/0	#6 solid	65BKB	HCPK4	2 X Sleeve#6S	1
CC7-4-1/0#8	1/0	#8	65BKB	HCPK4	2 X Sleeve#8	1
CC7-4-1/0#8S	1/0	#8 solid	65BKB	HCPK4	2 X Sleeve#8S	1
CC7-4-2/02/0	2/0	2/0	115BKB	HCPK4	-	1
CC7-4-2/01/0	2/0	1/0	115BKB	HCPK4	-	1
CC7-4-2/01/0S	2/0	1/0 solid	115BKB	HCPK4	-	1
CC7-4-2/0#1	2/0	#1	90BKB	HCPK4	-	1
CC7-4-2/0#1S	2/0	#1 solid	90BKB	HCPK4	-	1
CC7-4-2/0#2	2/0	#2	90BKB	HCPK4	-	1
CC7-4-2/0#4	2/0	#4	90BKB	HCPK4	-	1
CC7-4-2/0#6	2/0	#6	90BKB	HCPK4	2 X Sleeve#6	1
CC7-4-2/0#6S	2/0	#6 solid	90BKB	HCPK4	2 X Sleeve#6S	1
CC7-4-2/0#8	2/0	#8	65BKB	HCPK4	2 X Sleeve#8	1
CC7-4-2/0#8S	2/0	#8 solid	65BKB	HCPK4	2 X Sleeve#8S	1
CC7-4-3/03/0	3/0	3/0	150BKB	HCPK4	-	1
CC7-4-3/02/0	3/0	2/0	150BKB	HCPK4	-	1
CC7-4-3/01/0	3/0	1/0	115BKB	HCPK4	-	1
CC7-4-3/01/0S	3/0	1/0 solid	115BKB	HCPK4	-	1
CC7-4-3/0#1	3/0	#1	115BKB	HCPK4	-	1
CC7-4-3/0#1S	3/0	#1 solid	115BKB	HCPK4	-	1
CC7-4-3/0#2	3/0	#2	115BKB	HCPK4	-	1
CC7-4-3/0#2S	3/0	#2 solid	115BKB	HCPK4	-	1
CC7-4-3/0#4	3/0	#4	115BKB	HCPK4	-	1
CC7-4-3/0#6	3/0	#6	90BKB	HCPK4	2 X Sleeve#6	1
CC7-4-3/0#6S	3/0	#6 solid	90BKB	HCPK4	2 X Sleeve#6S	1
CC7-4-3/0#8	3/0	#8	90BKB	HCPK4	2 X Sleeve#8	1
CC7-4-3/0#8S	3/0	#8 solid	90BKB	HCPK4	2 X Sleeve#8S	1

Exothermic welding system

CC7 cable to cable

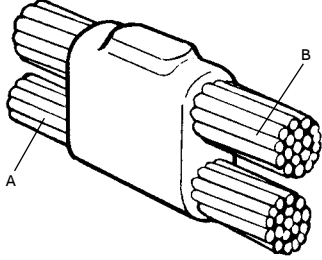

- Stranded conductor
- Solid circular conductor

CC7 (cont'd)

Cat. no.	Wire size (AWG or kcmil)		Welding powder size	Handle clamp type	Sleeve	Std. qty.
	A	B				
CC7-4-4/0S4/0	4/0 solid	4/0	200BKB	HCPK4	-	1
CC7-4-4/0S4/0S	4/0 solid	4/0 solid	200BKB	HCPK4	-	1
CC7-4-4/0S3/0	4/0 solid	3/0	200BKB	HCPK4	-	1
CC7-4-4/0S2/0	4/0 solid	2/0	150BKB	HCPK4	-	1
CC7-4-4/0S1/0	4/0 solid	1/0	150BKB	HCPK4	-	1
CC7-4-4/0S1/0S	4/0 solid	1/0 solid	150BKB	HCPK4	-	1
CC7-4-4/0S#1	4/0 solid	#1	150BKB	HCPK4	-	1
CC7-4-4/0S#1S	4/0 solid	#1 solid	150BKB	HCPK4	-	1
CC7-4-4/0S#2	4/0 solid	#2	150BKB	HCPK4	-	1
CC7-4-4/0S#2S	4/0 solid	#2 solid	150BKB	HCPK4	-	1
CC7-4-4/0S#4	4/0 solid	#4	150BKB	HCPK4	-	1
CC7-4-4/0S#6	4/0 solid	#6	90BKB	HCPK4	2 X Sleeve#6	1
CC7-4-4/0S#6S	4/0 solid	#6 solid	90BKB	HCPK4	2 X Sleeve#6S	1
CC7-4-4/0S#8	4/0 solid	#8	90BKB	HCPK4	2 X Sleeve#8	1
CC7-4-4/0S#8S	4/0 solid	#8 solid	90BKB	HCPK4	2 X Sleeve#8S	1
CC7-4-4/04/0	4/0	4/0	200BKB	HCPK4	-	1
CC7-4-4/04/0S	4/0	4/0 solid	200BKB	HCPK4	-	1
CC7-4-4/03/0	4/0	3/0	200BKB	HCPK4	-	1
CC7-4-4/02/0	4/0	2/0	150BKB	HCPK4	-	1
CC7-4-4/01/0	4/0	1/0	150BKB	HCPK4	-	1
CC7-4-4/01/0S	4/0	1/0 solid	150BKB	HCPK4	-	1
CC7-4-4/0#1	4/0	#1	150BKB	HCPK4	-	1
CC7-4-4/0#1S	4/0	#1 solid	150BKB	HCPK4	-	1
CC7-4-4/0#2	4/0	#2	150BKB	HCPK4	-	1
CC7-4-4/0#2S	4/0	#2 solid	150BKB	HCPK4	-	1
CC7-4-4/0#4	4/0	#4	150BKB	HCPK4	-	1
CC7-4-4/0#6	4/0	#6	90BKB	HCPK4	2 X Sleeve#6	1
CC7-4-4/0#6S	4/0	#6 solid	90BKB	HCPK4	2 X Sleeve#6S	1
CC7-4-4/0#8	4/0	#8	90BKB	HCPK4	2 X Sleeve#8	1
CC7-4-4/0#8S	4/0	#8 solid	90BKB	HCPK4	2 X Sleeve#8S	1

Exothermic welding system

CC11 cable to cable

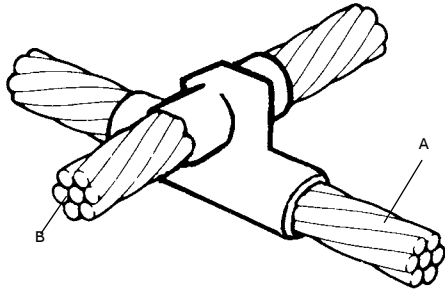

- Stranded conductor
- Solid circular conductor

CC11

Cat. no.	Wire size (AWG or kcmil)		Welding powder size	Handle clamp type	Sleeve	Std. qty.
	A	B				
CC11-7-#6S#6S	#6 solid	#6 solid	32BKB	HCPK7	4 X Sleeve#6S	1
CC11-7-#6#6	#6	#6	45BKB	HCPK7	4 X Sleeve#6	1
CC11-7-#4#4	#4	#4	65BKB	HCPK7	-	1
CC11-7-#2#2	#2	#2	90BKB	HCPK7	-	1
CC11-7-#2#4	#2	#4	65BKB	HCPK7	-	1
CC11-7-#2S#2S	#2 solid	#2 solid	90BKB	HCPK7	-	1
CC11-7-#1#1	#1	#1	115BKB	HCPK7	-	1
CC11-7-#1#2	#1	#2	90BKB	HCPK7	-	1
CC11-7-#1#4	#1	#4	90BKB	HCPK7	-	1
CC11-7-1/01/0	1/0	1/0	150BKB	HCPK7	-	1
CC11-7-1/0#1	1/0	#1	150BKB	HCPK7	-	1
CC11-7-1/0#2	1/0	#2	115BKB	HCPK7	-	1
CC11-7-1/0#4	1/0	#4	115BKB	HCPK7	-	1
CC11-7-2/02/0	2/0	2/0	200BKB	HCPK7	-	1
CC11-7-2/01/0	2/0	1/0	200BKB	HCPK7	-	1
CC11-7-2/0#1	2/0	#1	150BKB	HCPK7	-	1
CC11-7-2/0#2	2/0	#2	150BKB	HCPK7	-	1
CC11-7-3/03/0	3/0	3/0	250BKB	HCPK7	-	1
CC11-7-3/02/0	3/0	2/0	200BKB	HCPK7	-	1
CC11-7-3/01/0	3/0	1/0	200BKB	HCPK7	-	1
CC11-7-3/0#1	3/0	#1	150BKB	HCPK7	-	1
CC11-7-3/0#2	3/0	#2	150BKB	HCPK7	-	1
CC11-7-4/04/0	4/0	4/0	250BKB	HCPK7	-	1
CC11-7-4/03/0	4/0	3/0	250BKB	HCPK7	-	1
CC11-7-4/02/0	4/0	2/0	200BKB	HCPK7	-	1
CC11-7-4/01/0	4/0	1/0	200BKB	HCPK7	-	1
CC11-7-4/0#1	4/0	#1	150BKB	HCPK7	-	1
CC11-7-4/0#2	4/0	#2	150BKB	HCPK7	-	1
CC11-7-250K250K	250	250	2 X 150BKB	HCPK7	-	1
CC11-7-250K4/0	250	4/0	2 X 150BKB	HCPK7	-	1
CC11-7-250K3/0	250	3/0	2 X 150BKB	HCPK7	-	1
CC11-7-250K2/0	250	2/0	250BKB	HCPK7	-	1
CC11-7-250K1/0	250	1/0	250BKB	HCPK7	-	1
CC11-7-250K#1	250	#1	200BKB	HCPK7	-	1
CC11-7-250K#2	250	#2	150BKB	HCPK7	-	1

Exothermic welding system

CC11 cable to cable

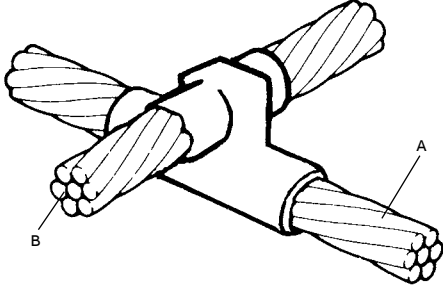

- Stranded conductor
- Solid circular conductor

CC11 (cont'd)

Cat. no.	Wire size (AWG or kcmil)		Welding powder size	Handle clamp type	Sleeve	Std. qty.
	A	B				
CC11-8-300K300K	300	300	2 X 200BKB	HCPK8	-	1
CC11-8-300K250K	300	250	2 X 200BKB	HCPK8	-	1
CC11-7-300K4/0	300	4/0	2 X 150BKB	HCPK7	-	1
CC11-7-300K3/0	300	3/0	2 X 150BKB	HCPK7	-	1
CC11-7-300K2/0	300	2/0	250BKB	HCPK7	-	1
CC11-7-300K1/0	300	1/0	250BKB	HCPK7	-	1
CC11-7-300K#1	300	#1	200BKB	HCPK7	-	1
CC11-7-300K#2	300	#2	150BKB	HCPK7	-	1
CC11-8-350K350K	350	350	2 X 250BKB	HCPK8	-	1
CC11-8-350K300K	350	300	2 X 250BKB	HCPK8	-	1
CC11-8-350K250K	350	250	2 X 250BKB	HCPK8	-	1
CC11-8-350K4/0	350	4/0	2 X 200BKB	HCPK8	-	1
CC11-8-350K3/0	350	3/0	2 X 200BKB	HCPK8	-	1
CC11-7-350K2/0	350	2/0	2 X 150BKB	HCPK7	-	1
CC11-7-350K1/0	350	1/0	250BKB	HCPK7	-	1
CC11-7-350K#1	350	#1	200BKB	HCPK7	-	1
CC11-7-350K#2	350	#2	200BKB	HCPK7	-	1
CC11-8-500K500K	500	500	3 X 250BKB	HCPK8	-	1
CC11-8-500K350K	500	350	3 X 200BKB	HCPK8	-	1
CC11-8-500K300K	500	300	3 X 200BKB	HCPK8	-	1
CC11-8-500K250K	500	250	2 X 250BKB	HCPK8	-	1
CC11-8-500K4/0	500	4/0	2 X 250BKB	HCPK8	-	1
CC11-8-500K3/0	500	3/0	2 X 250BKB	HCPK8	-	1
CC11-8-500K2/0	500	2/0	2 X 200BKB	HCPK8	-	1
CC11-8-500K1/0	500	1/0	2 X 150BKB	HCPK8	-	1

Exothermic welding system

CR1 cable to ground rod

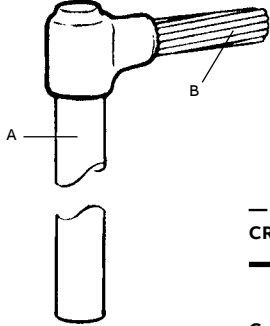

- Stranded conductor
- Solid circular conductor

CR1

Cat. no.	Rod size A	Wire size (AWG or kcmil) B	Welding powder size	Handle clamp type	Sleeve	Std. qty.
CR1-3-500#6	½ in. Nominal diameter actual shank dia. 0.476 in. (non UL rod)	#6	65BKB	HCPK3	1 X Sleeve#6	1
CR1-3-500#6S		#6 solid	65BKB	HCPK3	1 X Sleeve#6S	1
CR1-3-500#4		#4	65BKB	HCPK3	-	1
CR1-3-500#4S		#4 solid	45BKB	HCPK3	-	1
CR1-3-500#2		#2	65BKB	HCPK3	-	1
CR1-3-500#2S		#2 solid	65BKB	HCPK3	-	1
CR1-4-500#1		#1	65BKB	HCPK4	-	1
CR1-4-5001/0		1/0	90BKB	HCPK4	-	1
CR1-4-5001/0S		1/0 solid	90BKB	HCPK4	-	1
CR1-4-5002/0		2/0	90BKB	HCPK4	-	1
CR1-4-5003/0		3/0	90BKB	HCPK4	-	1
CR1-4-5004/0		4/0	90BKB	HCPK4	-	1
CR1-4-500250K		250	90BKB	HCPK4	-	1
CR1-4-500300K		300	90BKB	HCPK4	-	1
CR1-3-500L#6	½ in. True diameter actual shank dia. 0.502 in. (UL rod)	#6	45BKB	HCPK3	1 X Sleeve#6	1
CR1-3-500L#6S		#6 solid	45BKB	HCPK3	1 X Sleeve#6S	1
CR1-3-500L#4		#4	45BKB	HCPK3	-	1
CR1-3-500L#4S		#4 solid	45BKB	HCPK3	-	1
CR1-3-500L#2		#2	65BKB	HCPK3	-	1
CR1-3-500L#2S		#2 solid	65BKB	HCPK3	-	1
CR1-4-500L#1		#1	65BKB	HCPK4	-	1
CR1-4-500L1/0		1/0	90BKB	HCPK4	-	1
CR1-4-500L1/0S		1/0 solid	90BKB	HCPK4	-	1
CR1-4-500L2/0		2/0	90BKB	HCPK4	-	1
CR1-4-500L3/0		3/0	90BKB	HCPK4	-	1
CR1-4-500L4/0		4/0	90BKB	HCPK4	-	1
CR1-4-500L250K		250	90BKB	HCPK4	-	1
CR1-4-500L300K		300	90BKB	HCPK4	-	1

For connections to extensible (threaded) rods – remove top threaded section.

Exothermic welding system

CR1 cable to ground rod

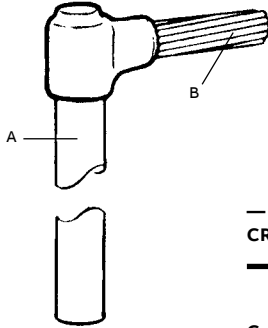

- Stranded conductor
- Solid circular conductor

CR1 (cont'd)

Cat. no.	Rod size A	Wire size (AWG or kcmil) B	Welding powder size	Handle clamp type	Sleeve	Std. qty.
CR1-3-625#6	3/8 in. Nominal diameter actual shank dia. 0.560 in.	#6	65BKB	HCPK4	1 X Sleeve#6	1
CR1-3-625#6S		#6 solid	65BKB	HCPK4	1 X Sleeve#6S	1
CR1-3-625#4		#4	65BKB	HCPK4	-	1
CR1-3-625#4S		#4 solid	65BKB	HCPK4	-	1
CR1-4-625#2		#2	65BKB	HCPK4	-	1
CR1-4-625#2S		#2 solid	65BKB	HCPK4	-	1
CR1-4-625#1		#1	65BKB	HCPK4	-	1
CR1-4-6251/0		1/0	90BKB	HCPK4	-	1
CR1-4-6251/0S	1/0 solid	90BKB	HCPK4	-	1	
CR1-4-6252/0		2/0	90BKB	HCPK4	-	1
CR1-4-6253/0		3/0	90BKB	HCPK4	-	1
CR1-4-6254/0		4/0	90BKB	HCPK4	-	1
CR1-4-625250K		250	90BKB	HCPK4	-	1
CR1-4-625300K		300	115BKB	HCPK4	-	1
CR1-4-625350K		350	115BKB	HCPK4	-	1
CR1-4-625500K		500	150BKB	HCPK4	-	1
CR1-3-750#6	3/4 in. Nominal diameter actual shank dia. 0.678 in.	#6	32BKB	HCPK3	1 X Sleeve#6	1
CR1-3-750#6S		#6 solid	32BKB	HCPK3	1 X Sleeve#6S	1
CR1-3-750#4		#4	45BKB	HCPK3	-	1
CR1-3-750#4S		#4 solid	45BKB	HCPK3	-	1
CR1-4-750#2		#2	90BKB	HCPK4	-	1
CR1-4-750#2S		#2 solid	90BKB	HCPK4	-	1
CR1-4-750#1		#1	90BKB	HCPK4	-	1
CR1-4-7501/0		1/0	90BKB	HCPK4	-	1
CR1-4-7501/0S	1/0 solid	90BKB	HCPK4	-	1	
CR1-4-7502/0		2/0	90BKB	HCPK4	-	1
CR1-4-7503/0		3/0	90BKB	HCPK4	-	1
CR1-4-7504/0		4/0	90BKB	HCPK4	-	1
CR1-4-750250K		250	90BKB	HCPK4	-	1
CR1-4-750300K		300	115BKB	HCPK4	-	1
CR1-4-750350K		350	115BKB	HCPK4	-	1
CR1-4-750500K		500	150BKB	HCPK4	-	1

For connections to extensible (threaded) rods – remove top threaded section.

Exothermic welding system

CR2 cable to ground rod

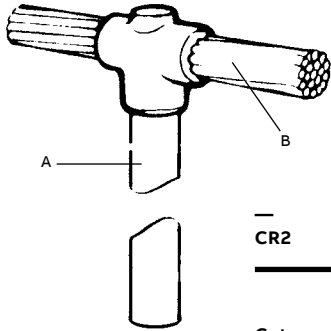

- Stranded conductor
- Solid circular conductor

CR2

Cat. no.	Rod size A	Wire size (AWG or kcmil) B	Welding powder size	Handle clamp type	Sleeve	Std. qty.
CR2-3-500#6	½ in. Nominal diameter actual shank dia. 0.476 in. (non UL rod)	#6	65BKB	HCPK3	Sleeve#6	-
CR2-3-500#6S		#6 solid	65BKB	HCPK3	Sleeve#6S	-
CR2-3-500#4		#4	65BKB	HCPK3	-	-
CR2-3-500#4S		#4 solid	65BKB	HCPK3	-	-
CR2-4-500#2		#2	90BKB	HCPK3	-	-
CR2-4-500#2S		#2 solid	90BKB	HCPK3	-	-
CR2-4-500#1		#1	90BKB	HCPK4	-	-
CR2-4-5001/0		1/0	90BKB	HCPK4	-	-
CR2-4-5001/0S		1/0 solid	90BKB	HCPK4	-	-
CR2-4-5002/0		2/0	90BKB	HCPK4	-	-
CR2-4-5003/0		3/0	115BKB	HCPK4	-	-
CR2-4-5004/0		4/0	115BKB	HCPK4	-	-
CR2-4-500250K		250	150BKB	HCPK4	-	-
CR2-4-500300K		300	200BKB	HCPK4	-	-
CR2-3-500L#6	½ in. True diameter actual shank dia. 0.502 in. (UL rod)	#6	65BKB	HCPK3	Sleeve#6	-
CR2-3-500L#6S		#6 solid	65BKB	HCPK3	Sleeve#6S	-
CR2-3-500L#4		#4	65BKB	HCPK3	-	-
CR2-3-500L#4S		#4 solid	65BKB	HCPK3	-	-
CR2-4-500L#2		#2	90BKB	HCPK3	-	-
CR2-4-500L#2S		#2 solid	90BKB	HCPK3	-	-
CR2-4-500L#1		#1	90BKB	HCPK4	-	-
CR2-4-500L1/0		1/0	90BKB	HCPK4	-	-
CR2-4-500L1/0S		1/0 solid	90BKB	HCPK4	-	-
CR2-4-500L2/0		2/0	90BKB	HCPK4	-	-
CR2-4-500L3/0		3/0	115BKB	HCPK4	-	-
CR2-4-500L4/0		4/0	115BKB	HCPK4	-	-
CR2-4-500L250K		250	150BKB	HCPK4	-	-
CR2-4-500L300K		300	200BKB	HCPK4	-	-

For connections to extensible (threaded) rods – remove top threaded section.

Exothermic welding system

CR2 cable to ground rod

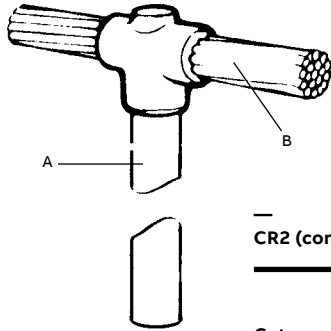

- Stranded conductor
- Solid circular conductor

CR2 (cont'd)

Cat. no.	Rod size A	Wire size (AWG or kcmil) B	Welding powder size	Handle clamp type	Sleeve	Std. qty.
CR2-3-625#6	3/8 in. Nominal diameter actual shank dia. 0.560 in.	#6	32BKB	HCPK3	Sleeve#6	-
CR2-3-625#6S		#6 solid	32BKB	HCPK3	Sleeve#6S	-
CR2-3-625#4		#4	32BKB	HCPK3	-	-
CR2-3-625#4S		#4 solid	32BKB	HCPK3	-	-
CR2-4-625#2		#2	90BKB	HCPK4	-	-
CR2-4-625#2S		#2 solid	90BKB	HCPK4	-	-
CR2-4-625#1		#1	90BKB	HCPK4	-	-
CR2-4-6251/0		1/0	90BKB	HCPK4	-	-
CR2-4-6251/0S	1/0 solid	115BKB	HCPK4	-	-	
CR2-4-6252/0		2/0	115BKB	HCPK4	-	-
CR2-4-6253/0		3/0	115BKB	HCPK4	-	-
CR2-4-6254/0		4/0	115BKB	HCPK4	-	-
CR2-4-625250K		250	150BKB	HCPK4	-	-
CR2-4-625300K		300	200BKB	HCPK4	-	-
CR2-4-625350K		350	200BKB	HCPK4	-	-
CR2-4-625500K		500	200BKB	HCPK4	-	-
CR2-3-750#6	3/8 in. Nominal diameter actual shank dia. 0.678 in.	#6	65BKB	HCPK3	Sleeve#6	1
CR2-3-750#6S		#6 solid	65BKB	HCPK3	Sleeve#6S	1
CR2-3-750#4		#4	65BKB	HCPK3	-	1
CR2-3-750#4S		#4 solid	65BKB	HCPK3	-	1
CR2-4-750#2		#2	90BKB	HCPK4	-	1
CR2-4-750#2S		#2 solid	90BKB	HCPK4	-	1
CR2-4-750#1		#1	90BKB	HCPK4	-	1
CR2-4-7501/0		1/0	115BKB	HCPK4	-	1
CR2-4-7501/0S	1/0 solid	115BKB	HCPK4	-	1	
CR2-4-7502/0		2/0	115BKB	HCPK4	-	1
CR2-4-7503/0		3/0	115BKB	HCPK4	-	1
CR2-4-7504/0		4/0	115BKB	HCPK4	-	1
CR2-4-750250K		250	150BKB	HCPK4	-	1
CR2-4-750300K		300	200BKB	HCPK4	-	1
CR2-4-750350K		350	200BKB	HCPK4	-	1
CR2-4-750500K		500	200BKB	HCPK4	-	1

For connections to extensible (threaded) rods – remove top threaded section.

Exothermic welding system

CR3 cable to ground rod

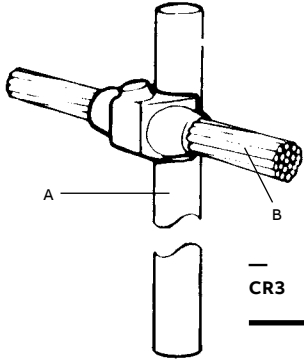

- Stranded conductor
- Solid circular conductor

Cat. no.	Wire size		Welding powder size	Handle clamp type	Sleeve	Std. qty.
	Rod size A	(AWG or kcmil) B				
CR3-9-5001/0	½ in. Nominal diameter actual shank dia. 0.476 in. (non UL rod)	1/0	115BKB	HCPK4 and FRAME1	-	1
CR3-9-5001/0S		1/0 solid	115BKB	HCPK4 and FRAME1	-	1
CR3-9-5002/0		2/0	115BKB	HCPK4 and FRAME1	-	1
CR3-9-5003/0		3/0	150BKB	HCPK4 and FRAME1	-	1
CR3-9-5004/0		4/0	150BKB	HCPK4 and FRAME1	-	1
CR3-9-500250K		250	150BKB	HCPK4 and FRAME1	-	1
CR3-9-500300K		300	200BKB	HCPK4 and FRAME1	-	1
CR3-9-500L1/0	½ in. Nominal diameter actual shank dia. 0.502 in. (UL rod)	1/0	115BKB	HCPK4 and FRAME1	-	1
CR3-9-500L1/0S		1/0 solid	115BKB	HCPK4 and FRAME1	-	1
CR3-9-500L2/0		2/0	115BKB	HCPK4 and FRAME1	-	1
CR3-9-500L3/0		3/0	150BKB	HCPK4 and FRAME1	-	1
CR3-9-500L4/0		4/0	150BKB	HCPK4 and FRAME1	-	1
CR3-9-500L250K		250	150BKB	HCPK4 and FRAME1	-	1
CR3-9-500300K		300	200BKB	HCPK4 and FRAME1	-	1
CR3-9-6251/0	¾ in. Nominal diameter actual shank dia. 0.560 in.	1/0	115BKB	HCPK4 and FRAME1	-	1
CR3-9-6251/0S		1/0 solid	115BKB	HCPK4 and FRAME1	-	1
CR3-9-6252/0		2/0	115BKB	HCPK4 and FRAME1	-	1
CR3-9-6253/0		3/0	150BKB	HCPK4 and FRAME1	-	1
CR3-9-6254/0		4/0	150BKB	HCPK4 and FRAME1	-	1
CR3-9-625250K		250	150BKB	HCPK4 and FRAME1	-	1
CR3-9-625300K		300	200BKB	HCPK4 and FRAME1	-	1
CR3-9-625350K	350	250BKB	HCPK4 and FRAME1	-	1	
CR3-10-625500K		500	2 X 200BKB	HCPK5 and FRAME2	-	1
CR3-9-7501/0	¾ in. Nominal diameter actual shank dia. 0.678 in.	1/0	115BKB	HCPK5 and FRAME2	-	1
CR3-9-7501/0S		1/0 solid	115BKB	HCPK4 and FRAME1	-	1
CR3-9-7502/0		2/0	115BKB	HCPK4 and FRAME1	-	1
CR3-9-7503/0		3/0	115BKB	HCPK4 and FRAME1	-	1
CR3-9-7504/0		4/0	115BKB	HCPK4 and FRAME1	-	1
CR3-9-750250K		250	200BKB	HCPK4 and FRAME1	-	1
CR3-9-750300K		300	200BKB	HCPK4 and FRAME1	-	1
CR3-10-750350K		350	2 X 150BKB	HCPK5 and FRAME2	-	1
CR3-10-750500K		500	2 X 250BKB	HCPK5 and FRAME2	-	1

For connections to extensible (threaded) rods – remove top threaded section.

Exothermic welding system

CRE1 and CRE3 cable to rebar

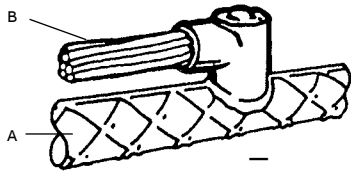

- Stranded conductor
- Solid circular conductor

CRE1

Cat. no.	Rod size A	Wire size (AWG or kcmil) B	Welding powder size	Handle clamp type	Sleeve	Pkg.	Std. qty.
CRE1-4-#43R	3	#4	32BKB	HCPK4	-	-	1
CRE1-4-#2S3R	3	2 solid	45BKB	HCPK4	-	-	1
CRE1-4-#23R	3	#2	45BKB	HCPK4	-	-	1
CRE1-4-#13R	3	#1	65BKB	HCPK4	-	-	1
CRE1-4-1/03R	3	1/0	90BKB	HCPK4	-	-	1
CRE1-4-2/03R	3	2/0	90BKB	HCPK4	-	-	1
CRE1-4-3/03R	3	3/0	115BKB	HCPK4	-	-	1
CRE1-3-#4Z	4 to 7	#4	32BKB	HCPK3B	-	Pack-A	1
CRE1-3-#2SZ	4 to 7	#2 solid	45BKB	HCPK3B	-	Pack-A	1
CRE1-3-#2Z	4 to 7	#2	45BKB	HCPK3B	-	Pack-A	1
CRE1-3-#1Z	4 to 7	#1	65BKB	HCPK3B	-	Pack-A	1
CRE1-3-1/0Z	4 to 7	1/0	90BKB	HCPK3B	-	Pack-A	1
CRE1-3-2/0Z	4 to 7	2/0	90BKB	HCPK3B	-	Pack-A	1
CRE1-3-3/0Z	4 to 7	3/0	115BKB	HCPK3B	-	Pack-A	1
CRE1-3-4/0Z	4 to 7	4/0	115BKB	HCPK3B	-	Pack-A	1
CRE1-3-#4Y	8 to 11	#4	32BKB	HCPK3B	-	Pack-A	1
CRE1-3-#2SY	8 to 11	#2 solid	45BKB	HCPK3B	-	Pack-A	1
CRE1-3-#2Y	8 to 11	#2	45BKB	HCPK3B	-	Pack-A	1
CRE1-3-#1Y	8 to 11	#1	65BKB	HCPK3B	-	Pack-A	1
CRE1-3-1/0Y	8 to 11	1/0	90BKB	HCPK3B	-	Pack-A	1
CRE1-3-2/0Y	8 to 11	2/0	90BKB	HCPK3B	-	Pack-A	1
CRE1-3-3/0Y	8 to 11	3/0	115BKB	HCPK3B	-	Pack-A	1
CRE1-3-4/0Y	8 to 11	4/0	115BKB	HCPK3B	-	Pack-A	1

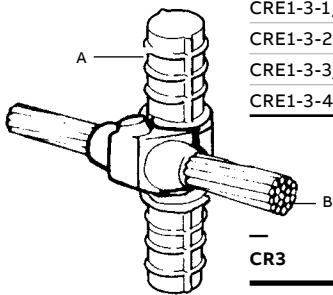

- Stranded conductor
- Solid circular conductor

CR3

Cat. no.	Rod size A	Wire size (AWG or kcmil) B	Welding powder size	Handle clamp type	Sleeve	Pkg.	Std. qty.
CRE3-3-#4Z	4 to 7	#4	90BKB	HCPK3A	-	Pack-A	1
CRE3-3#2SZ	4 to 7	#2 solid	90BKB	HCPK3A	-	Pack-A	1
CRE3-3-#2Z	4 to 7	#2	90BKB	HCPK3A	-	Pack-A	1
CRE3-4-#1Z	4 to 7	#1	115BKB	HCPK3A	-	Pack-A	1
CRE3-4-1/0Z	4 to 7	1/0	115BKB	HCPK3A	-	Pack-A	1
CRE3-4-2/0Z	4 to 7	2/0	115BKB	HCPK3A	-	Pack-A	1
CRE3-4-3/0Z	4 to 7	3/0	150BKB	HCPK3A	-	Pack-A	1
CRE3-4-4/0Z	4 to 7	4/0	150BKB	HCPK3A	-	Pack-A	1
CRE3-3-#4Y	8 to 11	#4	90BKB	HCPK3A	-	Pack-A	1
CRE3-3-#2SY	8 to 11	#2 solid	90BKB	HCPK3A	-	Pack-A	1
CRE3-3-#2Y	8 to 11	#2	90BKB	HCPK3A	-	Pack-A	1
CRE3-4-#1Y	8 to 11	#1	115BKB	HCPK3A	-	Pack-A	1
CRE3-4-1/0Y	8 to 11	1/0	115BKB	HCPK3A	-	Pack-A	1
CRE3-4-2/0Y	8 to 11	2/0	115BKB	HCPK3A	-	Pack-A	1
CRE3-4-3/0Y	8 to 11	3/0	150BKB	HCPK3A	-	Pack-A	1
CRE3-4-4/0Y	8 to 11	4/0	150BKB	HCPK3A	-	Pack-A	1

Exothermic welding system

CRE4 and CRE6 cable to rebar

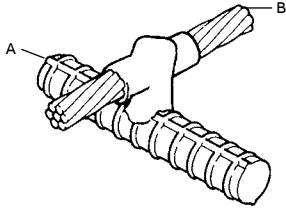

- Stranded conductor
- Solid circular conductor

CRE4

Cat. no.	Rod size A	Wire size (AWG or kcmil) B	Welding powder size	Handle clamp type	Sleeve	Pkg.	Std. qty
CRE4-3-#4Z	4 to 7	#4	65BKB	HCPK3B	-	Pack-A	1
CRE4-3-#2SZ	4 to 7	#2 solid	90BKB	HCPK3B	-	Pack-A	1
CRE4-3-#2Z	4 to 7	#2	90BKB	HCPK3B	-	Pack-A	1
CRE4-3-#1Z	4 to 7	#1	90BKB	HCPK3B	-	Pack-A	1
CRE4-3-1/OZ	4 to 7	1/0	115BKB	HCPK3B	-	Pack-A	1
CRE4-3-2/OZ	4 to 7	2/0	115BKB	HCPK3B	-	Pack-A	1
CRE4-3-3/OZ	4 to 7	3/0	115BKB	HCPK3B	-	Pack-A	1
CRE4-3-4/OZ	4 to 7	4/0	115BKB	HCPK3B	-	Pack-A	1
CRE4-3-#4Y	8 to 11	#4	65BKB	HCPK3B	-	Pack-A	1
CRE4-3-#2SY	8 to 11	#2 solid	90BKB	HCPK3B	-	Pack-A	1
CRE4-3-#2Y	8 to 11	#2	90BKB	HCPK3B	-	Pack-A	1
CRE4-3-#1Y	8 to 11	#1	90BKB	HCPK3B	-	Pack-A	1
CRE4-3-1/OY	8 to 11	1/0	115BKB	HCPK3B	-	Pack-A	1
CRE4-3-2/OY	8 to 11	2/0	115BKB	HCPK3B	-	Pack-A	1
CRE4-3-3/OY	8 to 11	3/0	115BKB	HCPK3B	-	Pack-A	1
CRE4-3-4/OY	8 to 11	4/0	115BKB	HCPK3B	-	Pack-A	1

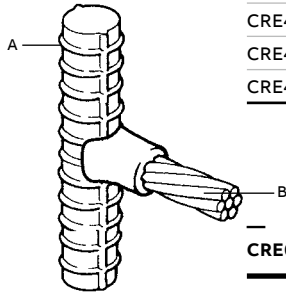

- Stranded conductor
- Solid circular conductor

CRE6

Cat. no.	Rod size A	Wire size (AWG or kcmil) B	Welding powder size	Handle clamp type	Sleeve	Pkg.	Std. qty.
CRE6-3-#4Z	4 to 7	#4	65BKB	HCPK3A	-	Pack-A	1
CRE6-3#2SZ	4 to 7	#2 solid	65BKB	HCPK3A	-	Pack-A	1
CRE6-3-#2Z	4 to 7	#2	65BKB	HCPK3A	-	Pack-A	1
CRE6-3-#1Z	4 to 7	#1	90BKB	HCPK3A	-	Pack-A	1
CRE6-4-1/OZ	4 to 7	1/0	115BKB	HCPK3A	-	Pack-A	1
CRE6-4-2/OZ	4 to 7	2/0	115BKB	HCPK3A	-	Pack-A	1
CRE6-4-3/OZ	4 to 7	3/0	150BKB	HCPK3A	-	Pack-A	1
CRE6-4-4/OZ	4 to 7	4/0	150BKB	HCPK3A	-	Pack-A	1
CRE6-3-#4Y	8 to 11	#4	65BKB	HCPK3A	-	Pack-A	1
CRE6-3-#2SY	8 to 11	#2 solid	65BKB	HCPK3A	-	Pack-A	1
CRE6-3-#2Y	8 to 11	#2	65BKB	HCPK3A	-	Pack-A	1
CRE6-3-#1Y	8 to 11	#1	90BKB	HCPK3A	-	Pack-A	1
CRE6-4-1/OY	8 to 11	1/0	115BKB	HCPK3A	-	Pack-A	1
CRE6-4-2/OY	8 to 11	2/0	115BKB	HCPK3A	-	Pack-A	1
CRE6-4-3/OY	8 to 11	3/0	150BKB	HCPK3A	-	Pack-A	1
CRE6-4-4/OY	8 to 11	4/0	150BKB	HCPK3A	-	Pack-A	1

Exothermic welding system

CS1 and CS2 cable to steel surface and pipe

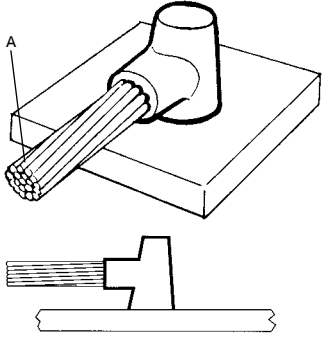

- Stranded conductor
- Solid circular conductor

CS1 – For flat surfaces

Cat. no.	Wire size (AWG or kcmil) A	Welding powder size	Handle clamp type	Sleeve	Std. qty.
CS1-4-1/0	1/0	90BKB	HCPK4	–	1
CS1-4-2/0	2/0	90BKB	HCPK4	–	1
CS1-4-3/0	3/0	115BKB	HCPK4	–	1
CS1-4-4/0	4/0	115BKB	HCPK4	–	1
CS1-4-250K	250	115BKB	HCPK4	–	1
CS1-4-300K	300	150BKB	HCPK4	–	1
CS1-4-350K	350	200BKB	HCPK4	–	1
CS1-4-500K	500	200BKB	HCPK4	–	1
CS1-4-750K	750	2 X 150BKB	HCPK4	–	1
CS1-4-1000K	1,000	2 X 200BKB	HCPK4	–	1

Mold Sealing Compound (MSC) will be required if surface is uneven.

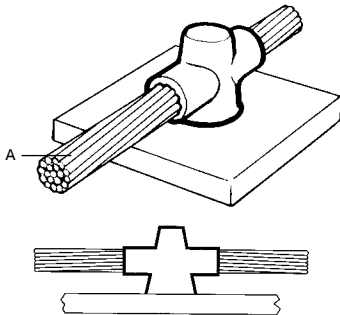

- Stranded conductor
- Solid circular conductor

CS2 – For flat surfaces

Cat. no.	Wire size (AWG or kcmil) A	Welding powder size	Handle clamp type	Sleeve	Std. qty.
CS2-4-1/0	1/0	90BKB	HCPK4	–	1
CS2-4-2/0	2/0	115BKB	HCPK4	–	1
CS2-4-3/0	3/0	115BKB	HCPK4	–	1
CS2-4-4/0	4/0	150BKB	HCPK4	–	1
CS2-4-250K	250	150BKB	HCPK4	–	1
CS2-4-300K	300	200BKB	HCPK4	–	1
CS2-4-350K	350	250BKB	HCPK4	–	1
CS2-5-500K	500	2 X 150BKB	HCPK4	–	1

Mold sealing compound (MSC) will be required if surface is uneven.

Exothermic welding system

CS3 cable to steel surface and pipe

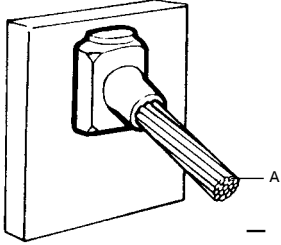

- Stranded conductor
- Solid circular conductor

CS3 – For flat surfaces

Cat. no.	Wire size (AWG or kcmil) A	Welding powder size	Handle clamp type	Sleeve	Std. qty.
CS3-4-#6	#6	45BKB	HCPK4	Sleeve#6	1
CS3-4-#4	#4	45BKB	HCPK4	-	1
CS3-4-#2S	#2 solid	45BKB	HCPK4	-	1
CS3-4-#2	#2	45BKB	HCPK4	-	1
CS3-4-#1	#1	65BKB	HCPK4	-	1
CS3-4-1/0	1/0	90BKB	HCPK4	-	1
CS3-4-2/0	2/0	90BKB	HCPK4	-	1
CS3-4-3/0	3/0	115BKB	HCPK4	-	1
CS3-4-4/0	4/0	115BKB	HCPK4	-	1
CS3-4-250K	250	115BKB	HCPK4	-	1
CS3-4-300K	300	150BKB	HCPK4	-	1
CS3-4-350K	350	200BKB	HCPK4	-	1
CS3-4-500K	500	200BKB	HCPK4	-	1
CS3-5-750K	750	2 X 150BKB	HCPK5	-	1
CS3-5-1000K	1,000	2 X 200BKB	HCPK5	-	1

Mold sealing compound (MSC) will be required if surface is uneven.

Exothermic welding system

CS3 cable to steel surface and pipe

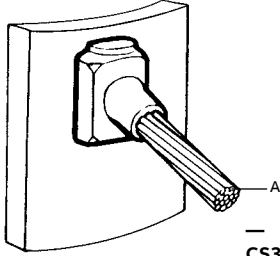

- Stranded conductor
- Solid circular conductor

CS3 – For pipes

Cat. no.	Wire size (AWG or kcmil) A	Pipe size (in.)	Welding powder size	Handle clamp type	Sleeve	Std. qty.
CS3-4-#4C	#4	1½ to 2¾	45BKB	HCPK4	–	1
CS3-4-#4D	#4	2¾ to 6½	45BKB	HCPK4	–	1
CS3-4-#4F	#4	6½ to 10	45BKB	HCPK4	–	1
CS3-4-#4G	#4	10 to 14	45BKB	HCPK4	–	1
CS3-4-#2SC	#2 solid	1½ to 2¾	45BKB	HCPK4	–	1
CS3-4-#2SD	#2 solid	2¾ to 6½	45BKB	HCPK4	–	1
CS3-4-#2SF	#2 solid	6½ to 10	45BKB	HCPK4	–	1
CS3-4-#2SG	#2 solid	10 to 14	45BKB	HCPK4	–	1
CS3-4-#2C	#2	1½ to 2¾	45BKB	HCPK4	–	1
CS3-4-#2D	#2	2¾ to 6½	45BKB	HCPK4	–	1
CS3-4-#2F	#2	6½ to 10	45BKB	HCPK4	–	1
CS3-4-#2G	#2	10 to 14	45BKB	HCPK4	–	1
CS3-4-#1C	#1	1½ to 2¾	65BKB	HCPK4	–	1
CS3-4-#1D	#1	2¾ to 6½	65BKB	HCPK4	–	1
CS3-4-#1F	#1	6½ to 10	65BKB	HCPK4	–	1
CS3-4-#1G	#1	10 to 14	65BKB	HCPK4	–	1
CS3-4-#1/0C	1/0	1½ to 2¾	90BKB	HCPK4	–	1
CS3-4-#1/0D	1/0	2¾ to 6½	90BKB	HCPK4	–	1
CS3-4-#1/0F	1/0	6½ to 10	90BKB	HCPK4	–	1
CS3-4-#1/0G	1/0	10 to 14	90BKB	HCPK4	–	1
CS3-4-#2/0C	2/0	1½ to 2¾	90BKB	HCPK4	–	1
CS3-4-#2/0D	2/0	2¾ to 6½	90BKB	HCPK4	–	1
CS3-4-#2/0F	2/0	6½ to 10	90BKB	HCPK4	–	1
CS3-4-#2/0G	2/0	10 to 14	90BKB	HCPK4	–	1
CS3-4-#3/0C	3/0	1½ to 2¾	115BKB	HCPK4	–	1
CS3-4-#3/0D	3/0	2¾ to 6½	115BKB	HCPK4	–	1
CS3-4-#3/0F	3/0	6½ to 10	115BKB	HCPK4	–	1
CS3-4-#3/0G	3/0	10 to 14	115BKB	HCPK4	–	1
CS3-4-#4/0C	4/0	1½ to 2¾	115BKB	HCPK4	–	1
CS3-4-#4/0D	4/0	2¾ to 6½	115BKB	HCPK4	–	1
CS3-4-#4/0F	4/0	6½ to 10	115BKB	HCPK4	–	1
CS3-4-#4/0G	4/0	10 to 14	115BKB	HCPK4	–	1

Over 14 in. use CS3 for flat surface
Use mold sealing compound (MSC) to ensure effective sealing.

Exothermic welding system

CS4 cable to steel surface and pipe

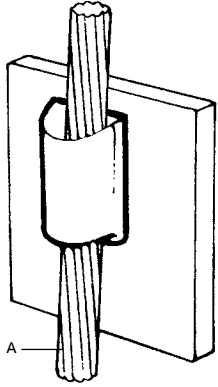

- Stranded conductor
- Solid circular conductor

—
CS4 – For flat surfaces

Cat. no.	Wire size (AWG or kcmil) A	Welding powder size	Handle clamp type	Sleeve	Std. qty.
CS4-4-#6	#6	90BKB	HCPK4	Sleeve#6	1
CS4-4-#4	#4	90BKB	HCPK4	-	1
CS4-4-#2S	#2 solid	115BKB	HCPK4	-	1
CS4-4-#2	#2	115BKB	HCPK4	-	1
CS4-4-#1	#1	115BKB	HCPK4	-	1
CS4-5-1/0	1/0	200BKB	HCPK5	-	1
CS4-5-2/0	2/0	200BKB	HCPK5	-	1
CS4-5-3/0	3/0	250BKB	HCPK5	-	1
CS4-5-4/0	4/0	250BKB	HCPK5	-	1
CS4-5-250K	250	250BKB	HCPK5	-	1

Mold sealing compound (MSC) will be required if surface is uneven.

Exothermic welding system

CS4 cable to steel surface and pipe

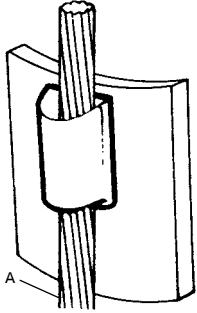

- Stranded conductor
- Solid circular conductor

CS4 – For pipes

Cat. no.	Wire size (AWG or kcmil) A	Pipe size (in.)	Welding powder size	Handle clamp type	Sleeve	std. qty.
CS4-4-#4C	#4	1½ to 2¾	90BKB	HCPK4	-	1
CS4-4-#4D	#4	2¾ to 6½	90BKB	HCPK4	-	1
CS4-4-#4F	#4	6½ to 10	90BKB	HCPK4	-	1
CS4-4-#4G	#4	10 to 14	90BKB	HCPK4	-	1
CS4-4-#2SC	#2 solid	1½ to 2¾	115BKB	HCPK4	-	1
CS4-4-#2SD	#2 solid	2¾ to 6½	115BKB	HCPK4	-	1
CS4-4-#2SF	#2 solid	6½ to 10	115BKB	HCPK4	-	1
CS4-4-#2SG	#2 solid	10 to 14	115BKB	HCPK4	-	1
CS4-4-#2C	#2	1½ to 2¾	115BKB	HCPK4	-	1
CS4-4-#2D	#2	2¾ to 6½	115BKB	HCPK4	-	1
CS4-4-#2F	#2	6½ to 10	115BKB	HCPK4	-	1
CS4-4-#2G	#2	10 to 14	115BKB	HCPK4	-	1
CS4-4-#1C	#1	1½ to 2¾	115BKB	HCPK4	-	1
CS4-4-#1D	#1	2¾ to 6½	115BKB	HCPK4	-	1
CS4-4-#1F	#1	6½ to 10	115BKB	HCPK4	-	1
CS4-4-#1G	#1	10 to 14	115BKB	HCPK4	-	1
CS4-5-1/0C	1/0	1½ to 2¾	200BKB	HCPK5	-	1
CS4-5-1/0D	1/0	2¾ to 6½	200BKB	HCPK5	-	1
CS4-5-1/0F	1/0	6½ to 10	200BKB	HCPK5	-	1
CS4-5-1/0G	1/0	10 to 14	200BKB	HCPK5	-	1
CS4-5-2/0C	2/0	1½ to 2¾	200BKB	HCPK5	-	1
CS4-5-2/0D	2/0	2¾ to 6½	200BKB	HCPK5	-	1
CS4-5-2/0F	2/0	6½ to 10	200BKB	HCPK5	-	1
CS4-5-2/0G	2/0	10 to 14	200BKB	HCPK5	-	1
CS4-5-3/0C	3/0	1½ to 2¾	250BKB	HCPK5	-	1
CS4-5-3/0D	3/0	2¾ to 6½	250BKB	HCPK5	-	1
CS4-5-3/0F	3/0	6½ to 10	250BKB	HCPK5	-	1
CS4-5-3/0G	3/0	10 to 14	250BKB	HCPK5	-	1
CS4-5-4/0C	4/0	1½ to 2¾	250BKB	HCPK5	-	1
CS4-5-4/0D	4/0	2¾ to 6½	250BKB	HCPK5	-	1
CS4-5-4/0F	4/0	6½ to 10	250BKB	HCPK5	-	1
CS4-5-4/0G	4/0	10 to 14	250BKB	HCPK5	-	1

Over 14 in. use CS4 for flat surface
Use mold sealing compound (MSC) to ensure effective sealing.

Exothermic welding system

CS7 cable to steel surface and pipe

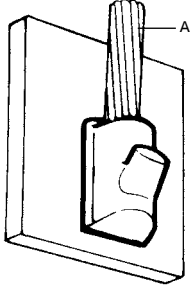

- Stranded conductor
- Solid circular conductor

—
CS7 – For flat surfaces

Cat. no.	Wire size (AWG or kcmil) A	Welding powder size	Handle clamp type	Sleeve	Std. qty.
CS7-4-#4	#4	65BKB	HCPK4	–	1
CS7-4-#2S	#2 solid	65BKB	HCPK4	–	1
CS7-4-#2	#2	65BKB	HCPK4	–	1
CS7-4-#1	#1	90BKB	HCPK4	–	1
CS7-4-1/0	1/0	90BKB	HCPK4	–	1
CS7-4-2/0	2/0	150BKB	HCPK4	–	1
CS7-5-3/0	3/0	200BKB	HCPK4	–	1
CS7-5-4/0	4/0	200BKB	HCPK4	–	1
CS7-5-250K	250	200BKB	HCPK4	–	1
CS7-5-300K	300	250BKB	HCPK4	–	1
CS7-6-350K	350	2 X 150BKB	HCPK5	–	1
CS7-6-500K	500	2 X 200BKB	HCPK5	–	1

Use mold sealing compound (MSC) to ensure effective sealing.

Exothermic welding system

CS7 cable to steel surface and pipe

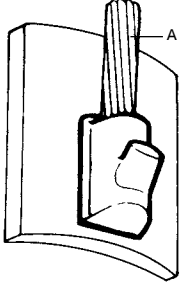

- Stranded conductor
- Solid circular conductor

CS7 – For pipes

Cat. no.	Wire size (AWG) A	Pipe size (in.)	Welding powder size	Handle clamp type	Sleeve	Std. qty.
CS7-4-#4C	#4	1½ to 2¾	65BKB	HCPK4	–	1
CS7-4-#4D	#4	2¾ to 6½	65BKB	HCPK4	–	1
CS7-4-#4F	#4	6½ to 10	65BKB	HCPK4	–	1
CS7-4-#4G	#4	10 to 14	65BKB	HCPK4	–	1
CS7-4-#2SC	#2 solid	1½ to 2¾	65BKB	HCPK4	–	1
CS7-4-#2SD	#2 solid	2¾ to 6½	65BKB	HCPK4	–	1
CS7-4-#2SF	#2 solid	6½ to 10	65BKB	HCPK4	–	1
CS7-4-#2SG	#2 solid	10 to 14	65BKB	HCPK4	–	1
CS7-4-#2C	#2	1½ to 2¾	65BKB	HCPK4	–	1
CS7-4-#2D	#2	2¾ to 6½	65BKB	HCPK4	–	1
CS7-4-#2F	#2	6½ to 10	65BKB	HCPK4	–	1
CS7-4-#2G	#2	10 to 14	65BKB	HCPK4	–	1
CS7-4-#1C	#1	1½ to 2¾	90BKB	HCPK4	–	1
CS7-4-#1D	#1	2¾ to 6½	90BKB	HCPK4	–	1
CS7-4-#1F	#1	6½ to 10	90BKB	HCPK4	–	1
CS7-4-#1G	#1	10 to 14	90BKB	HCPK4	–	1
CS7-4-1/0C	1/0	1½ to 2¾	90BKB	HCPK4	–	1
CS7-4-1/0D	1/0	2¾ to 6½	90BKB	HCPK4	–	1
CS7-4-1/0F	1/0	6½ to 10	90BKB	HCPK4	–	1
CS7-4-1/0G	1/0	10 to 14	90BKB	HCPK4	–	1
CS7-4-2/0C	2/0	1½ to 2¾	150BKB	HCPK4	–	1
CS7-4-2/0D	2/0	2¾ to 6½	150BKB	HCPK4	–	1
CS7-4-2/0F	2/0	6½ to 10	150BKB	HCPK4	–	1
CS7-4-2/0G	2/0	10 to 14	150BKB	HCPK4	–	1
CS7-5-3/0C	3/0	1½ to 2¾	200BKB	HCPK4	–	1
CS7-5-3/0D	3/0	2¾ to 6½	200BKB	HCPK4	–	1
CS7-5-3/0F	3/0	6½ to 10	200BKB	HCPK4	–	1
CS7-5-3/0G	3/0	10 to 14	200BKB	HCPK4	–	1
CS7-5-4/0C	4/0	1½ to 2¾	200BKB	HCPK4	–	1
CS7-5-4/0D	4/0	2¾ to 6½	200BKB	HCPK4	–	1
CS7-5-4/0F	4/0	6½ to 10	200BKB	HCPK4	–	1
CS7-5-4/0G	4/0	10 to 14	200BKB	HCPK4	–	1

Over 14 in. use CS7 for flat surface.

Use mold sealing compound (MSC) to ensure effective sealing.

Exothermic welding system

CS8 and CS9 cable to steel surface and pipe

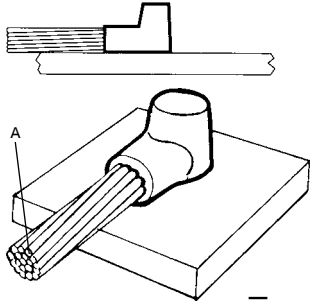

- Stranded conductor
- Solid circular conductor

CS8 – For flat surfaces

Cat. no.	Wire size (AWG) A	Welding powder size	Handle clamp type	Sleeve	Std. qty.
CS8-2-#6	#6	45BKB	HCPK2	Sleeve#6	1
CS8-2-#4	#4	45BKB	HCPK2	-	1
CS8-2-#2S	#2 solid	45BKB	HCPK2	-	1
CS8-2-#2	#2	45BKB	HCPK2	-	1
CS8-2-#1	#1	65BKB	HCPK2	-	1

Use mold sealing compound (MSC) to ensure effective sealing.

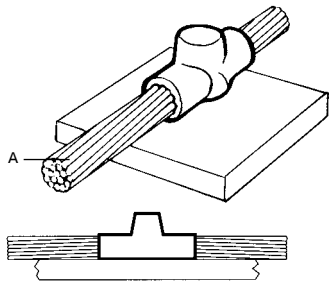

- Stranded conductor
- Solid circular conductor

CS9 – For flat surfaces

Cat. no.	Wire size (AWG) A	Welding powder size	Handle clamp type	Sleeve	Std. qty.
CS9-2-#6	#6	45BKB	HCPK2	Sleeve#6	1
CS9-2-#4	#4	45BKB	HCPK2	-	1
CS9-2-#2S	#2 solid	45BKB	HCPK2	-	1
CS9-2-#2	#2	45BKB	HCPK2	-	1
CS9-2-#1	#1	65BKB	HCPK2	-	1

Use mold sealing compound (MSC) to ensure effective sealing.

Exothermic welding system

CS25 cable to steel surface and pipe

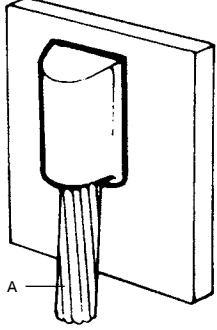

- Stranded conductor
- Solid circular conductor

—
CS25 – For flat surfaces

Cat. no.	Wire size (AWG or kcmil) A	Welding powder size	Handle clamp type	Sleeve	Std. qty.
CS25-4-#4	#4	65BKB	HCPK4	–	1
CS25-4-#2S	#2 solid	65BKB	HCPK4	–	1
CS25-4-#2	#2	65BKB	HCPK4	–	1
CS25-4-#1	#1	90BKB	HCPK4	–	1
CS25-4-1/0	1/0	115BKB	HCPK4	–	1
CS25-4-2/0	2/0	115BKB	HCPK4	–	1
CS25-4-3/0	3/0	150BKB	HCPK4	–	1
CS25-4-4/0	4/0	150BKB	HCPK4	–	1
CS25-4-250K	250	200BKB	HCPK4	–	1
CS25-4-300K	300	200BKB	HCPK4	–	1
CS25-4-350K	350	250BKB	HCPK4	–	1
CS25-4-500K	500	250BKB	HCPK4	–	1

Use mold sealing compound (MSC) to ensure effective sealing.

Exothermic welding system

CS25 cable to steel surface and pipe

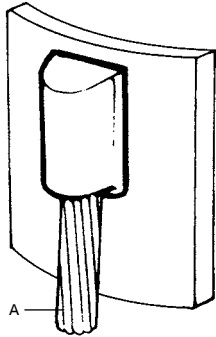

- Stranded conductor
- Solid circular conductor

—
CS25 – For pipes

Cat. no.	Wire size (AWG) A	Pipe size (in.)	Welding powder size	Handle clamp type	Sleeve	Std. qty.
CS25-4-#4C	#4	1½ to 2¾	65BKB	HCPK4	–	1
CS25-4-#4D	#4	2¾ to 6½	65BKB	HCPK4	–	1
CS25-4-#4F	#4	6½ to 10	65BKB	HCPK4	–	1
CS25-4-#4G	#4	10 to 14	65BKB	HCPK4	–	1
CS25-4-#2SC	#2 solid	1½ to 2¾	65BKB	HCPK4	–	1
CS25-4-#2SD	#2 solid	2¾ to 6½	65BKB	HCPK4	–	1
CS25-4-#2SF	#2 solid	6½ to 10	65BKB	HCPK4	–	1
CS25-4-#2SG	#2 solid	10 to 14	65BKB	HCPK4	–	1
CS25-4-#2C	#2	1½ to 2¾	65BKB	HCPK4	–	1
CS25-4-#2D	#2	2¾ to 6½	65BKB	HCPK4	–	1
CS25-4-#2F	#2	6½ to 10	65BKB	HCPK4	–	1
CS25-4-#2G	#2	10 to 14	65BKB	HCPK4	–	1
CS25-4-#1C	#1	1½ to 2¾	90BKB	HCPK4	–	1
CS25-4-#1D	#1	2¾ to 6½	90BKB	HCPK4	–	1
CS25-4-#1F	#1	6½ to 10	90BKB	HCPK4	–	1
CS25-4-#1G	#1	10 to 14	90BKB	HCPK4	–	1
CS25-4-1/0C	1/0	1½ to 2¾	90BKB	HCPK4	–	1
CS25-4-1/0D	1/0	2¾ to 6½	90BKB	HCPK4	–	1
CS25-4-1/0F	1/0	6½ to 10	90BKB	HCPK4	–	1
CS25-4-1/0G	1/0	10 to 14	90BKB	HCPK4	–	1
CS25-4-2/0C	2/0	1½ to 2¾	150BKB	HCPK4	–	1
CS25-4-2/0D	2/0	2¾ to 6½	150BKB	HCPK4	–	1
CS25-4-2/0F	2/0	6½ to 10	150BKB	HCPK4	–	1
CS25-4-2/0G	2/0	10 to 14	150BKB	HCPK4	–	1
CS25-4-3/0C	3/0	1½ to 2¾	200BKB	HCPK4	–	1
CS25-4-3/0D	3/0	2¾ to 6½	200BKB	HCPK4	–	1
CS25-4-3/0F	3/0	6½ to 10	200BKB	HCPK4	–	1
CS25-4-3/0G	3/0	10 to 14	200BKB	HCPK4	–	1
CS25-4-4/0C	4/0	1½ to 2¾	200BKB	HCPK4	–	1
CS25-4-4/0D	4/0	2¾ to 6½	200BKB	HCPK4	–	1
CS25-4-4/0F	4/0	6½ to 10	200BKB	HCPK4	–	1
CS25-4-4/0G	4/0	10 to 14	200BKB	HCPK4	–	1

Over 14 in. use CS25 for flat surface.
Use mold sealing compound (MSC) to ensure effective sealing.

Exothermic welding system

CS27 cable to steel surface and pipe

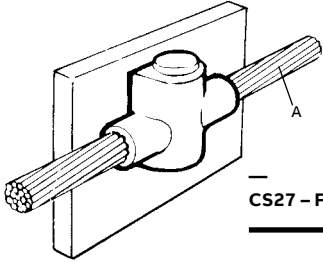

- Stranded conductor
- Solid circular conductor

CS27 – For flat surfaces

Cat. no.	Wire size (AWG or kcmil) A	Welding powder size	Handle clamp type	Sleeve	Std. qty.
CS27-4-#6	#6	45BKB	HCPK4	Sleeve#6	1
CS27-4-#4	#4	45BKB	HCPK4	-	1
CS27-4-#2S	#2 solid	45BKB	HCPK4	-	1
CS27-4-#2	#2	45BKB	HCPK4	-	1
CS27-4-#1	#1	65BKB	HCPK4	-	1
CS27-4-1/0	1/0	115BKB	HCPK4	-	1
CS27-4-2/0	2/0	115BKB	HCPK4	-	1
CS27-4-3/0	3/0	150BKB	HCPK4	-	1
CS27-4-4/0	4/0	150BKB	HCPK4	-	1
CS27-4-250K	250	150BKB	HCPK4	-	1

Exothermic welding system

CS27 cable to steel surface and pipe

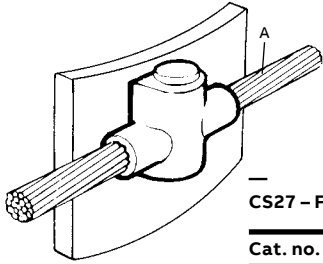

- Stranded conductor
- Solid circular conductor

CS27 – For pipes

Cat. no.	Wire size (AWG) A	Pipe size (in.)	Welding powder size	Handle clamp type	Sleeve	Std. qty.
CS27-4-#4C	#4	1½ to 2¾	45BKB	HCPK4	-	1
CS27-4-#4D	#4	2¾ to 6½	45BKB	HCPK4	-	1
CS27-4-#4F	#4	6½ to 10	45BKB	HCPK4	-	1
CS27-4-#4G	#4	10 to 14	45BKB	HCPK4	-	1
CS27-4-#2SC	#2 solid	1½ to 2¾	45BKB	HCPK4	-	1
CS27-4-#2SD	#2 solid	2¾ to 6½	45BKB	HCPK4	-	1
CS27-4-#2SF	#2 solid	6½ to 10	45BKB	HCPK4	-	1
CS27-4-#2SG	#2 solid	10 to 14	45BKB	HCPK4	-	1
CS27-4-#2C	#2	1½ to 2¾	45BKB	HCPK4	-	1
CS27-4-#2D	#2	2¾ to 6½	45BKB	HCPK4	-	1
CS27-4-#2F	#2	6½ to 10	45BKB	HCPK4	-	1
CS27-4-#2G	#2	10 to 14	45BKB	HCPK4	-	1
CS27-4-#1C	#1	1½ to 2¾	65BKB	HCPK4	-	1
CS27-4-#1D	#1	2¾ to 6½	65BKB	HCPK4	-	1
CS27-4-#1F	#1	6½ to 10	65BKB	HCPK4	-	1
CS27-4-#1G	#1	10 to 14	65BKB	HCPK4	-	1
CS27-4-110C	1/0	1½ to 2¾	115BKB	HCPK4	-	1
CS27-4-110D	1/0	2¾ to 6½	115BKB	HCPK4	-	1
CS27-4-110F	1/0	6½ to 10	115BKB	HCPK4	-	1
CS27-4-110G	1/0	10 to 14	115BKB	HCPK4	-	1
CS27-4-210C	2/0	1½ to 2¾	115BKB	HCPK4	-	1
CS27-4-210D	2/0	2¾ to 6½	115BKB	HCPK4	-	1
CS27-4-210F	2/0	6½ to 10	115BKB	HCPK4	-	1
CS27-4-210G	2/0	10 to 14	115BKB	HCPK4	-	1
CS27-4-310C	3/0	1½ to 2¾	150BKB	HCPK4	-	1
CS27-4-310D	3/0	2¾ to 6½	150BKB	HCPK4	-	1
CS27-4-310F	3/0	6½ to 10	150BKB	HCPK4	-	1
CS27-4-310G	3/0	10 to 14	150BKB	HCPK4	-	1
CS27-4-410C	4/0	1½ to 2¾	150BKB	HCPK4	-	1
CS27-4-410D	4/0	2¾ to 6½	150BKB	HCPK4	-	1
CS27-4-410F	4/0	6½ to 10	150BKB	HCPK4	-	1
CS27-4-410G	4/0	10 to 14	150BKB	HCPK4	-	1

Over 14 in. use CS27 for flat surface.
Use mold sealing compound (MSC) to ensure effective sealing.

Exothermic welding system

CS31 cable to steel surface and pipe

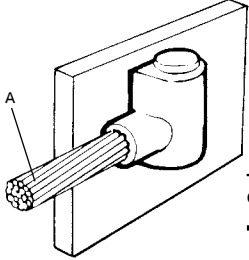

- Stranded conductor
- Solid circular conductor

CS31 – For flat surfaces

Cat. no.	Wire size (AWG or kcmil) A	Welding powder size	Handle clamp type	Sleeve	Std. qty.
CS31-4-#6	#6	45BKB	HCPK4	Sleeve#6	1
CS31-4-#4	#4	45BKB	HCPK4	-	1
CS31-4-#2S	#2 solid	45BKB	HCPK4	-	1
CS31-4-#2	#2	45BKB	HCPK4	-	1
CS31-4-#1	#1	65BKB	HCPK4	-	1
CS31-4-1/0	1/0	90BKB	HCPK4	-	1
CS31-4-2/0	2/0	90BKB	HCPK4	-	1
CS31-4-3/0	3/0	115BKB	HCPK4	-	1
CS31-4-4/0	4/0	115BKB	HCPK4	-	1
CS31-4-250K	250	115BKB	HCPK4	-	1

Add "R" or "L" to denote wire exiting left or right. (Example: CS31-6-#6R for #6 wire exiting on the right.)
Use mold sealing compound (MSC) to ensure effective sealing.

Exothermic welding system

CS31 cable to steel surface and pipe

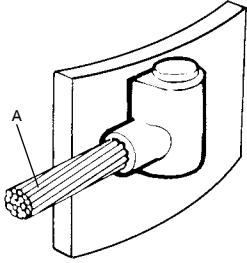

- Stranded conductor
- Solid circular conductor

CS31 – For pipes

Cat. no.	Wire size (AWG) A	Pipe size (in.)	Welding powder size	Handle clamp type	Sleeve	Std. qty.
CS31-4-#4C	#4	1½ to 2¾	45BKB	HCPK4	-	1
CS31-4-#4D	#4	2¾ to 6½	45BKB	HCPK4	-	1
CS31-4-#4F	#4	6½ to 10	45BKB	HCPK4	-	1
CS31-4-#4G	#4	10 to 14	45BKB	HCPK4	-	1
CS31-4-#2SC	#2 solid	1½ to 2¾	45BKB	HCPK4	-	1
CS31-4-#2SD	#2 solid	2¾ to 6½	45BKB	HCPK4	-	1
CS31-4-#2SF	#2 solid	6½ to 10	45BKB	HCPK4	-	1
CS31-4-#2SG	#2 solid	10 to 14	45BKB	HCPK4	-	1
CS31-4-#2C	#2	1½ to 2¾	45BKB	HCPK4	-	1
CS31-4-#2D	#2	2¾ to 6½	45BKB	HCPK4	-	1
CS31-4-#2F	#2	6½ to 10	45BKB	HCPK4	-	1
CS31-4-#2G	#2	10 to 14	45BKB	HCPK4	-	1
CS31-4-#1C	#1	1½ to 2¾	65BKB	HCPK4	-	1
CS31-4-#1D	#1	2¾ to 6½	65BKB	HCPK4	-	1
CS31-4-#1F	#1	6½ to 10	65BKB	HCPK4	-	1
CS31-4-#1G	#1	10 to 14	65BKB	HCPK4	-	1
CS31-4-1/0C	1/0	1½ to 2¾	90BKB	HCPK4	-	1
CS31-4-1/0D	1/0	2¾ to 6½	90BKB	HCPK4	-	1
CS31-4-1/0F	1/0	6½ to 10	90BKB	HCPK4	-	1
CS31-4-1/0G	1/0	10 to 14	90BKB	HCPK4	-	1
CS31-4-2/0C	2/0	1½ to 2¾	90BKB	HCPK4	-	1
CS31-4-2/0D	2/0	2¾ to 6½	90BKB	HCPK4	-	1
CS31-4-2/0F	2/0	6½ to 10	90BKB	HCPK4	-	1
CS31-4-2/0G	2/0	10 to 14	90BKB	HCPK4	-	1
CS31-4-3/0C	3/0	1½ to 2¾	115BKB	HCPK4	-	1
CS31-4-3/0D	3/0	2¾ to 6½	115BKB	HCPK4	-	1
CS31-4-3/0F	3/0	6½ to 10	115BKB	HCPK4	-	1
CS31-4-3/0G	3/0	10 to 14	115BKB	HCPK4	-	1
CS31-4-4/0C	4/0	1½ to 2¾	115BKB	HCPK4	-	1
CS31-4-4/0D	4/0	2¾ to 6½	115BKB	HCPK4	-	1
CS31-4-4/0F	4/0	6½ to 10	115BKB	HCPK4	-	1
CS31-4-4/0G	4/0	10 to 14	115BKB	HCPK4	-	1

Over 14 in. use CS31 for flat surface.

Add "R" or "L" to denote wire exiting left or right. (Example: CS31-6-#6R for #6 wire exiting on the right.)

Use mold sealing compound (MSC) to ensure effective sealing.

Exothermic welding system

CS32 cable to steel surface and pipe

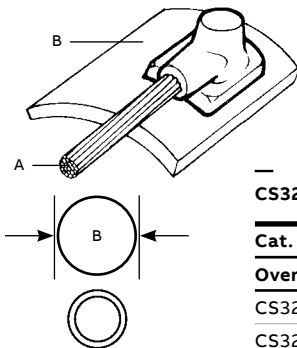

- Stranded conductor

CS32 – For pipes

Cat. no.	Wire size (AWG) A	Pipe size (in.)	Welding powder size	Handle clamp type	Sleeve	Std. qty.
Over 14 in. use CS8 for flat surface						
CS32-2-#4C	#4	1½ to 2¾	45BKB	HCPK2	–	1
CS32-2-#4D	#4	2¾ to 6½	45BKB	HCPK2	–	1
CS32-2-#4F	#4	6½ to 10	45BKB	HCPK2	–	1
CS32-2-#4G	#4	10 to 14	45BKB	HCPK2	–	1
CS32-2-#2SC	#2 solid	1½ to 2¾	45BKB	HCPK2	–	1
CS32-2-#2SD	#2 solid	2¾ to 6½	45BKB	HCPK2	–	1
CS32-2-#2SF	#2 solid	6½ to 10	45BKB	HCPK2	–	1
CS32-2-#2SG	#2 solid	10 to 14	45BKB	HCPK2	–	1
CS32-2-#2C	#2	1½ to 2¾	45BKB	HCPK2	–	1
CS32-2-#2D	#2	2¾ to 6½	45BKB	HCPK2	–	1
CS32-2-#2F	#2	6½ to 10	45BKB	HCPK2	–	1
CS32-2-#2G	#2	10 to 14	45BKB	HCPK2	–	1
CS32-2-#1D	#1	2¾ to 6½	65BKB	HCPK2	–	1
CS32-2-#1F	#1	6½ to 10	65BKB	HCPK2	–	1
CS32-2-#1G	#1	10 to 14	65BKB	HCPK2	–	1
Over 14 in. use CS1 for flat surface						
CS32-4-#1/OD	1/0	2¾ to 6½	90BKB	HCPK4	–	1
CS32-4-#1/OF	1/0	6½ to 10	90BKB	HCPK4	–	1
CS32-4-#1/OG	1/0	10 to 14	90BKB	HCPK4	–	1
CS32-4-#2/OD	2/0	2¾ to 6½	90BKB	HCPK4	–	1
CS32-4-#2/OF	2/0	6½ to 10	90BKB	HCPK4	–	1
CS32-4-#2/OG	2/0	10 to 14	90BKB	HCPK4	–	1
CS32-4-#3/OD	3/0	2¾ to 6½	90BKB	HCPK4	–	1
CS32-4-#3/OF	3/0	6½ to 10	90BKB	HCPK4	–	1
CS32-4-#3/OG	3/0	10 to 14	90BKB	HCPK4	–	1
CS32-4-#4/OD	4/0	2¾ to 6½	90BKB	HCPK4	–	1
CS32-4-#4/OF	4/0	6½ to 10	90BKB	HCPK4	–	1
CS32-4-#4/OG	4/0	10 to 14	90BKB	HCPK4	–	1

Add "R" or "L" to denote wire exiting left or right. (Example: CS31-6-#6R for #6 wire exiting on the right.)
Use mold sealing compound (MSC) to ensure effective sealing.

Exothermic welding system

CS34 cable to steel surface and pipe

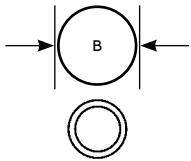
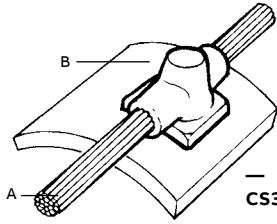

- Stranded conductor

CS34 – For pipes

Cat. no.	Wire size (AWG) A	Pipe size (in.)	Welding powder size	Handle clamp type	Sleeve	Std. qty.
Over 14 in. use CS8 for flat surface						
CS34-2-#4C	#4	1½ to 2¾	45BKB	HCPK2	–	1
CS34-2-#4D	#4	2¾ to 6½	45BKB	HCPK2	–	1
CS34-2-#4F	#4	6½ to 10	45BKB	HCPK2	–	1
CS34-2-#4G	#4	10 to 14	45BKB	HCPK2	–	1
CS34-2-#2SC	#2 solid	1½ to 2¾	45BKB	HCPK2	–	1
CS34-2-#2SD	#2 solid	2¾ to 6½	45BKB	HCPK2	–	1
CS34-2-#2SF	#2 solid	6½ to 10	45BKB	HCPK2	–	1
CS34-2-#2SG	#2 solid	10 to 14	45BKB	HCPK2	–	1
CS34-2-#2C	#2	1½ to 2¾	45BKB	HCPK2	–	1
CS34-2-#2D	#2	2¾ to 6½	45BKB	HCPK2	–	1
CS34-2-#2F	#2	6½ to 10	45BKB	HCPK2	–	1
CS34-2-#2G	#2	10 to 14	45BKB	HCPK2	–	1
CS34-2-#1D	#1	2¾ to 6½	65BKB	HCPK2	–	1
CS34-2-#1F	#1	6½ to 10	65BKB	HCPK2	–	1
CS34-2-#1G	#1	10 to 14	65BKB	HCPK2	–	1
Over 14 in. use CS1 for flat surface						
CS34-4-#1/OD	1/0	2¾ to 6½	90BKB	HCPK4	–	1
CS34-4-#1/OF	1/0	6½ to 10	90BKB	HCPK4	–	1
CS34-4-#1/OG	1/0	10 to 14	90BKB	HCPK4	–	1
CS34-4-#2/OD	2/0	2¾ to 6½	115BKB	HCPK4	–	1
CS34-4-#2/OF	2/0	6½ to 10	115BKB	HCPK4	–	1
CS34-4-#2/OG	2/0	10 to 14	115BKB	HCPK4	–	1
CS34-4-#3/OD	3/0	2¾ to 6½	115BKB	HCPK4	–	1
CS34-4-#3/OF	3/0	6½ to 10	115BKB	HCPK4	–	1
CS34-4-#3/OG	3/0	10 to 14	115BKB	HCPK4	–	1
CS34-4-#4/OD	4/0	2¾ to 6½	150BKB	HCPK4	–	1
CS34-4-#4/OF	4/0	6½ to 10	150BKB	HCPK4	–	1
CS34-4-#4/OG	4/0	10 to 14	150BKB	HCPK4	–	1

Use mold sealing compound (MSC) to ensure effective sealing.

Exothermic welding system

CB1 cable to bare

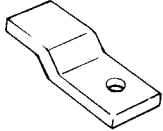
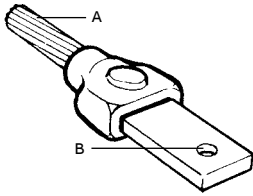

- Stranded conductor
- Solid circular conductor
- Rectangular tape or bar

CB1 – For pipes

Cat. no.	Wire size (AWG or kcmil) A	Bar size (in.) B	Welding powder size	Handle clamp type	Sleeve	Std. qty.
CB1-4-#4181	#4	1/8 X 1	45BKB	HCPK4	-	1
CB1-4-#2181	#2 solid	1/8 X 1	45BKB	HCPK4	-	1
CB1-4-#2181	#2	1/8 X 1	45BKB	HCPK4	-	1
CB1-4-#1181	#1	1/8 X 1	45BKB	HCPK4	-	1
CB1-4-1/0181	1/0	1/8 X 1	45BKB	HCPK4	-	1
CB1-4-1/03161	1/0	3/16 X 1	65BKB	HCPK4	-	1
CB1-4-1/0141	1/0	1/4 X 1	65BKB	HCPK4	-	1
CB1-4-2/0181	2/0	1/8 X 1	65BKB	HCPK4	-	1
CB1-4-2/03161	2/0	3/16 X 1	65BKB	HCPK4	-	1
CB1-4-2/0141	2/0	1/4 X 1	65BKB	HCPK4	-	1
CB1-4-3/018	3/0	1/8 X 1	65BKB	HCPK4	-	1
CB1-4-3/0161	2/0	3/16 X 1	90BKB	HCPK4	-	1
CB1-4-3/0141	2/0	1/4 X 1	90BKB	HCPK4	-	1
CB1-4-4/03161	4/0	3/16 X 1	90BKB	HCPK4	-	1
CB1-4-4/0141	4/0	1/4 X 1	90BKB	HCPK4	-	1
CB1-4-4/014112	4/0	1/4 X 1 1/2	90BKB	HCPK4	-	1
CB1-4-4/0142	4/0	1/4 X 2	90BKB	HCPK4	-	1
CB1-4-4/0143	4/0	1/4 X 3	90BKB	HCPK4	-	1
CB1-4-250K3161	250	3/16 X 1	90BKB	HCPK4	-	1
CB1-4-250K141	250	1/4 X 1	90BKB	HCPK4	-	1
CB1-4-250K14112	250	1/4 X 1 1/2	90BKB	HCPK4	-	1
CB1-4-250K142	250	1/4 X 2	90BKB	HCPK4	-	1
CB1-4-250K143	250	1/4 X 3	90BKB	HCPK4	-	1
CB1-4-300K141	300	1/4 X 1	90BKB	HCPK4	-	1
CB1-4-300K14112	300	1/4 X 1-1/2	90BKB	HCPK4	-	1
CB1-4-300K142	300	1/4 X 2	90BKB	HCPK4	-	1
CB1-4-300K143	300	1/4 X 3	90BKB	HCPK4	-	1
CB1-4-350K141	350	1/4 X 1	115BKB	HCPK4	-	1
CB1-4-350K14112	350	1/4 X 1 1/2	115BKB	HCPK4	-	1
CB1-4-350K142	350	1/4 X 2	115BKB	HCPK4	-	1
CB1-4-350K143	350	1/4 X 3	115BKB	HCPK4	-	1
CB1-4-500K14112	500	1/4 X 1 1/2	200BKB	HCPK4	-	1
CB1-4-500K142	500	1/4 X 2	200BKB	HCPK4	-	1
CB1-4-500K143	500	1/4 X 3	200BKB	HCPK4	-	1
CB1-4-500K38112	500	3/8 X 1 1/2	200BKB	HCPK4	-	1
CB1-5-750K142	750	1/4 X 2	2 X 150BKB	HCPK5	-	1
CB1-5-750K143	750	1/4 X 3	2 X 150BKB	HCPK5	-	1
CB1-5-750k38112	750	3/8 X 1 1/2	2 X 150BKB	HCPK5	-	1
CB1-5-750k382	750	3/8 X 2	2 X 150BKB	HCPK5	-	1
CB1-5-750K383	750	3/8 X 3	2 X 150BKB	HCPK5	-	1
CB1-5-1000K143	1,000	1/4 X 3	2 X 150BKB	HCPK5	-	1
CB1-5-1000K382	1,000	3/8 X 2	2 X 150BKB	HCPK5	-	1
CB1-5-1000K383	1,000	3/8 X 3	2 X 150BKB	HCPK5	-	1
CB1-5-1000K122	1,000	1/2 X 2	2 X 150BKB	HCPK5	-	1
CB1-5-1000K123	1,000	1/2 X 3	2 X 150BKB	HCPK5	-	1

Exothermic welding system

CB4 cable to bar

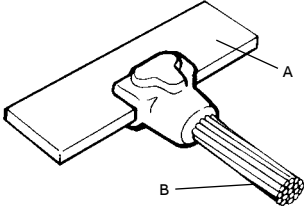

- Stranded conductor
- Solid circular conductor
- Rectangular tape or bar

CB4 – For flat surfaces

Cat. no.	Bar size (in.) A	Wire size (AWG or kcmil) B	Welding powder size	Handle clamp type	Sleeve	Std. qty.
CB4-4-#2S14112	¼ X 1½ and wider	#2 solid	45BKB	HCPK4	-	1
CB4-4-214112	¼ X 1½ and wider	#2	45BKB	HCPK4	-	1
CB4-4-1/014112	¼ X 1½ and wider	1/0	90BKB	HCPK4	-	1
CB4-4-2/014112	¼ X 1½ and wider	2/0	90BKB	HCPK4	-	1
CB4-4-3/014112	¼ X 1½ and wider	3/0	90BKB	HCPK4	-	1
CB4-4-4/014112	¼ X 1½ and wider	4/0	90BKB	HCPK4	-	1
CB4-4-250K14112	¼ X 1½ and wider	250	115BKB	HCPK4	-	1
CB4-4-300K14112	¼ X 1½ and wider	300	115BKB	HCPK4	-	1
CB4-4-350K14112	¼ X 1½ and wider	350	150BKB	HCPK4	-	1
CB4-4-500K1411	¼ X 1½ and wider	500	200BKB	HCPK4	-	1
CB4-4-#2S38112	⅜ X 1½ and wider	#2 solid	65BKB	HCPK4	-	1
CB4-4-#238112	⅜ X 1½ and wider	#2	65BKB	HCPK4	-	1
CB4-4-1/038112	⅜ X 1½ and wider	1/0	90BKB	HCPK4	-	1
CB4-4-2/038112	⅜ X 1½ and wider	2/0	90BKB	HCPK4	-	1
CB4-4-4/038112	⅜ X 1½ and wider	4/0	115BKB	HCPK4	-	1
CB4-4-250K38112	⅜ X 1½ and wider	250	150BKB	HCPK4	-	1
CB4-4-300K38112	⅜ X 1½ and wider	300	150BKB	HCPK4	-	1
CB4-4-350K38112	⅜ X 1½ and wider	350	200BKB	HCPK4	-	1
CB4-4-500K38112	⅜ X 1½ and wider	500	250BKB	HCPK4	-	1
CB4-5-750K38112	⅜ X 1½ and wider	750	2 X 150BKB	HCPK5	-	1
CB4-5-1000K38112	⅜ X 1½ and wider	1,000	2 X 200BKB	HCPK5	-	1
CB4-4-#2S12112	½ X 1½ and wider	#2 solid	90BKB	HCPK4	-	1
CB4-4-#212112	½ X 1½ and wider	#2	90BKB	HCPK4	-	1
CB4-4-1/012112	½ X 1½ and wider	1/0	115BKB	HCPK4	-	1
CB4-4-2/012112	½ X 1½ and wider	2/0	115BKB	HCPK4	-	1
CB4-4-3/012112	½ X 1½ and wider	3/0	150BKB	HCPK4	-	1
CB4-4-4/012112	½ X 1½ and wider	4/0	150BKB	HCPK4	-	1
CB4-4-250K12112	½ X 1½ and wider	250	200BKB	HCPK4	-	1
CB4-4-300K12112	½ X 1½ and wider	300	200BKB	HCPK4	-	1
CB4-4-350K12112	½ X 1½ and wider	350	250BKB	HCPK4	-	1
CB4-5-500K12112	½ X 1½ and wider	500	2 X 150BKB	HCPK5	-	1
CB4-5-750K12112	½ X 1½ and wider	750	2 X 200BKB	HCPK5	-	1
CB4-5-1000K12112	½ X 1½ and wider	1,000	2 X 250BKB	HCPK5	-	1

Exothermic welding system

CB29 cable to bar

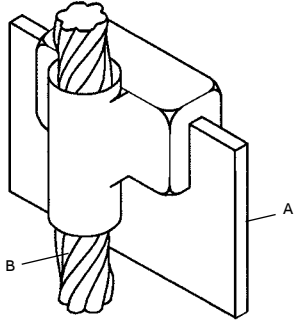

CB29 – For flat surfaces

Cat. no.	Bar size (in.) A	Wire size (AWG or kcmil) B	Welding powder size	Handle clamp type	Sleeve	Std. qty.
CB29-9-#2S142	¼ X 2 and wider	#2 solid	250BKB	HCPK4	–	1
CB29-9-#2142	¼ X 2 and wider	#2	250BKB	HCPK4	–	1
CB29-10-#1142	¼ X 2 and wider	#1	2 X 150BKB	HCPK5	–	1
CB29-10-1/0142	¼ X 2 and wider	1/0	2 X 200BKB	HCPK5	–	1
CB29-10-2/0142	¼ X 2 and wider	2/0	2 X 200BKB	HCPK5	–	1
CB29-10-4/0142	¼ X 2 and wider	4/0	2 X 250BKB	HCPK5	–	1
CB29-10-250K142	¼ X 2 and wider	250	2 X 250BKB	HCPK5	–	1
CB29-10-500K142	¼ X 2 and wider	500	2 X 250BKB	HCPK5	–	1
CB29-10-750K142	¼ X 2 and wider	750	3 X 200BKB	HCPK5	–	1
CB29-9-#2S382	⅜ X 2 and wider	#2 solid	250BKB	HCPK4	–	1
CB29-9-#2382	⅜ X 2 and wider	#2 solid	250BKB	HCPK4	–	1
CB29-10-#1382	⅜ X 2 and wider	#1	2 X 150BKB	HCPK5	–	1
CB29-10-1/0382	⅜ X 2 and wider	1/0	2 X 200BKB	HCPK5	–	1
CB29-102/0382	⅜ X 2 and wider	2/0	2 X 200BKB	HCPK5	–	1
CB29-104/0382	⅜ X 2 and wider	4/0	2 X 250BKB	HCPK5	–	1
CB29-10-250K382	⅜ X 2 and wider	250	2 X 250BKB	HCPK5	–	1
CB29-10-500K382	⅜ X 2 and wider	500	2 X 250BKB	HCPK5	–	1
CB29-10-750K382	⅜ X 2 and wider	750	3 X 200BKB	HCPK5	–	1
CB29-10-#2S122	½ X 2 and wider	#2 solid	2 X 150BKB	HCPK5	–	1
CB29-10-#2122	½ X 2 and wider	#2	2 X 150BKB	HCPK5	–	1
CB29-10-#1122	½ X 2 and wider	#1	2 X 200BKB	HCPK5	–	1
CB29-10-1/0122	½ X 2 and wider	1/0	2 X 250BKB	HCPK5	–	1
CB29-10-2/0122	½ X 2 and wider	2/0	2 X 250BKB	HCPK5	–	1
CB29-10-4/0122	½ X 2 and wider	4/0	3 X 200BKB	HCPK5	–	1
CB29-10-250K122	½ X 2 and wider	250	3 X 200BKB	HCPK5	–	1
CB29-10-500K122	½ X 2 and wider	500	3 X 200BKB	HCPK5	–	1
CB29-10-750K	½ X 2 and wider	750	3 X 250BKB	HCPK5	–	1

Use mold sealing compound (MSC) to ensure effective sealing.

Exothermic welding system

BB1 and BB2 bar to bar

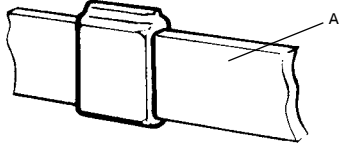

—
BB1 – For flat surfaces

Cat. no.	Bar size (in.) A	Welding powder size	Handle clamp type	Sleeve	Std. qty.
BB1-4-181	1/8 X 1	45BKB	HCPK4	–	1
BB1-4-18112	1/8 X 1 1/2	65BKB	HCPK4	–	1
BB1-4-182	1/8 X 2	90BKB	HCPK4	–	1
BB1-4-183	1/8 X 3	200BKB	HCPK4	–	1
BB1-4-184	1/8 X 4	250BKB	HCPK4	–	1
BB1-4-3161	3/16 X 1	65BKB	HCPK4	–	1
BB1-4-3162	3/16 X 2	115BKB	HCPK4	–	1
BB1-4-141	1/4 X 1	90BKB	HCPK4	–	1
BB1-4-14114	1/4 X 1 1/4	115BKB	HCPK4	–	1
BB1-4-14112	1/4 X 1 1/2	150BKB	HCPK4	–	1
BB1-4-142	1/4 X 2	200BKB	HCPK4	–	1
BB1-4-14212	1/4 X 2 1/2	250BKB	HCPK4	–	1
BB1-5-143	1/4 X 3	2 X 200BKB	HCPK5	–	1
BB1-5-144	1/4 X 4	2 X 250BKB	HCPK5	–	1
BB1-4-381	3/8 X 1	150BKB	HCPK5	–	1
BB1-4-38112	3/8 X 1 1/2	250BKB	HCPK4	–	1
BB1-5-382	3/8 X 2	2 X 150BKB	HCPK5	–	1
BB1-5-383	3/8 X 3	2 X 250BKB	HCPK5	–	1
BB1-5-384	3/8 X 4	3 X 200BKB	HCPK5	–	1
BB1-4-121	1/2 X 1	200BKB	HCPK4	–	1
BB1-5-122	1/2 X 2	2 X 200BKB	HCPK5	–	1

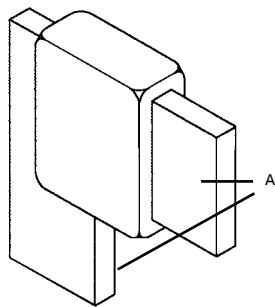

—
BB2 – For flat surfaces

Cat. no.	Bar size (in.) A	Welding powder size	Handle clamp type	Sleeve	Std. qty.
BB2-4-181	1/8 X 1	45BKB	HCPK4	–	1
BB2-4-18112	1/8 X 1 1/2	65BKB	HCPK4	–	1
BB2-4-182	1/8 X 2	90BKB	HCPK4	–	1
BB2-4-183	1/8 X 3	200BKB	HCPK4	–	1
BB2-4-184	1/8 X 4	250BKB	HCPK4	–	1
BB2-4-3161	3/16 X 1	65BKB	HCPK4	–	1
BB2-4-3162	3/16 X 2	115BKB	HCPK4	–	1
BB2-4-141	1/4 X 1	90BKB	HCPK4	–	1
BB2-4-14114	1/4 X 1 1/4	115BKB	HCPK4	–	1
BB2-4-14112	1/4 X 1 1/2	150BKB	HCPK4	–	1
BB2-4-142	1/4 X 2	200BKB	HCPK4	–	1
BB2-4-14212	1/4 X 2 1/2	250BKB	HCPK4	–	1
BB2-5-143	1/4 X 3	2 X 200BKB	HCPK5	–	1
BB2-5-144	1/4 X 4	2 X 250BKB	HCPK5	–	1
BB2-4-381	3/8 X 1	150BKB	HCPK5	–	1
BB2-4-38112	3/8 X 1 1/2	250BKB	HCPK4	–	1
BB2-5-382	3/8 X 2	2 X 150BKB	HCPK5	–	1
BB2-5-383	3/8 X 3	2 X 250BKB	HCPK5	–	1
BB2-5-384	3/8 X 4	3 X 200BKB	HCPK5	–	1
BB2-4-121	1/2 X 1	200BKB	HCPK4	–	1
BB2-5-122	1/2 X 2	2 X 200BKB	HCPK5	–	1

Exothermic welding system

BB3 and BB7 bar to bar

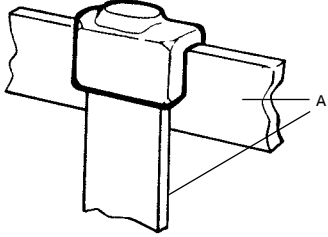

BB3 – For flat surfaces

Cat. no.	Bar size (in.) A	Welding powder size	Handle clamp type	Sleeve	Std. qty.
BB3-4-181	1/8 X 1	45BKB	HCPK4	-	1
BB3-4-18112	1/8 X 1 1/2	65BKB	HCPK4	-	1
BB3-4-182	1/8 X 2	90BKB	HCPK4	-	1
BB3-4-183	1/8 X 3	200BKB	HCPK4	-	1
BB3-4-184	1/8 X 4	250BKB	HCPK4	-	1
BB3-4-3161	3/16 X 1	65BKB	HCPK4	-	1
BB3-4-3162	3/16 X 2	115BKB	HCPK4	-	1
BB3-4-141	1/4 X 1	90BKB	HCPK4	-	1
BB3-4-14114	1/4 X 1 1/4	115BKB	HCPK4	-	1
BB3-4-14112	1/4 X 1 1/2	150BKB	HCPK4	-	1
BB3-4-142	1/4 X 2	200BKB	HCPK4	-	1
BB3-4-14212	1/4 X 2 1/2	250BKB	HCPK4	-	1
BB3-5-143	1/4 X 3	2 X 200BKB	HCPK5	-	1
BB3-5-144	1/4 X 4	2 X 250BKB	HCPK5	-	1
BB3-4-381	3/8 X 1	150BKB	HCPK5	-	1
BB3-4-38112	3/8 X 1 1/2	250BKB	HCPK4	-	1
BB3-5-382	3/8 X 2	2 X 150BKB	HCPK5	-	1
BB3-5-383	3/8 X 3	2 X 250BKB	HCPK5	-	1
BB3-5-384	3/8 X 4	3 X 200BKB	HCPK5	-	1
BB3-4-121	1/2 X 1	200BKB	HCPK4	-	1
BB3-5-122	1/2 X 2	2 X 200BKB	HCPK5	-	1

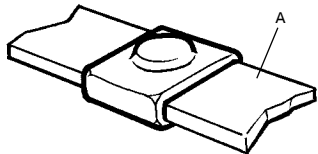

BB7 – For flat surfaces

Cat. no.	Bar size (in.) A	Welding powder size	Handle clamp type	Sleeve	Std. qty.
BB7-4-181	1/8 X 1	45BKB	HCPK4	-	1
BB7-4-18112	1/8 X 1 1/2	65BKB	HCPK4	-	1
BB7-4-182	1/8 X 2	90BKB	HCPK4	-	1
BB7-4-183	1/8 X 3	200BKB	HCPK4	-	1
BB7-4-184	1/8 X 4	250BKB	HCPK4	-	1
BB7-4-3161	3/16 X 1	65BKB	HCPK4	-	1
BB7-4-3162	3/16 X 2	115BKB	HCPK4	-	1
BB7-4-141	1/4 X 1	90BKB	HCPK4	-	1
BB7-4-14114	1/4 X 1 1/4	115BKB	HCPK4	-	1
BB7-4-14112	1/4 X 1 1/2	150BKB	HCPK4	-	1
BB7-4-142	1/4 X 2	200BKB	HCPK4	-	1
BB7-4-14212	1/4 X 2 1/2	250BKB	HCPK4	-	1
BB7-5-143	1/4 X 3	2 X 200BKB	HCPK5	-	1
BB7-5-144	1/4 X 4	2 X 250BKB	HCPK5	-	1
BB7-4-381	3/8 X 1	150BKB	HCPK5	-	1
BB7-4-38112	3/8 X 1 1/2	250BKB	HCPK5	-	1
BB7-5-382	3/8 X 2	2 X 150BKB	HCPK5	-	1
BB7-5-383	3/8 X 3	2 X 250BKB	HCPK5	-	1
BB7-5-384	3/8 X 4	3 X 200BKB	HCPK5	-	1
BB7-4-121	1/2 X 1	200BKB	HCPK4	-	1
BB7-5-122	1/2 X 2	2 X 200BKB	HCPK5	-	1

Exothermic welding system

BB14 bar to bar

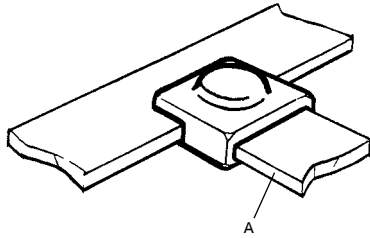

—
BB14 – For flat surfaces

Cat. no.	Bar size (in.) A	Welding powder size	Handle clamp type	Sleeve	Std. qty.
BB14-4-181	1/8 X 1	45BKB	HCPK4	-	1
BB14-4-18112	1/8 X 1 1/2	65BKB	HCPK4	-	1
BB14-4-182	1/8 X 2	90BKB	HCPK4	-	1
BB14-4-183	1/8 X 3	200BKB	HCPK4	-	1
BB14-4-184	1/8 X 4	250BKB	HCPK4	-	1
BB14-4-3161	3/16 X 1	65BKB	HCPK4	-	1
BB14-4-3162	3/16 X 2	115BKB	HCPK4	-	1
BB14-4-141	1/4 X 1	90BKB	HCPK4	-	1
BB14-4-14114	1/4 X 1 1/4	115BKB	HCPK4	-	1
BB14-4-14112	1/4 X 1 1/2	150BKB	HCPK4	-	1
BB14-4-142	1/4 X 2	200BKB	HCPK4	-	1
BB14-4-14212	1/4 X 2 1/2	250BKB	HCPK4	-	1
BB14-5-143	1/4 X 3	2 X 200BKB	HCPK5	-	1
BB14-5-144	1/4 X 4	2 X 250BKB	HCPK5	-	1
BB14-4-381	3/8 X 1	150BKB	HCPK5	-	1
BB14-4-38112	3/8 X 1 1/2	250BKB	HCPK4	-	1
BB14-5-382	3/8 X 2	2 X 150BKB	HCPK5	-	1
BB14-5-383	3/8 X 3	2 X 250BKB	HCPK5	-	1
BB14-5-384	3/8 X 4	3 X 200BKB	HCPK5	-	1
BB14-4-121	1/2 X 1	200BKB	HCPK4	-	1
BB14-5-122	1/2 X 2	2 X 200BKB	HCPK5	-	1

Exothermic welding system

BS1 and BS2 bar to steel surface

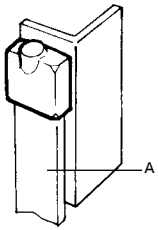
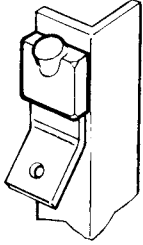

- Rectangular tape or bar

BS1 – For flat surfaces

Cat. no.	Bar size (in.) A	Welding powder size	Handle clamp type	Sleeve	Std. qty.
BS1-4-181	1/8 X 1	115BKB	HCPK4	4	1
BS1-4-18112	1/8 X 1 1/2	150BKB	HCPK4	4	1
BS1-4-182	1/8 X 2	200BKB	HCPK4	4	1
BS1-4-3161	3/16 X 1	150BKB	HCPK4	4	1
BS1-4-316112	3/16 X 1 1/2	200BKB	HCPK4	4	1
BS1-4-3162	3/16 X 2	250BKB	HCPK4	4	1
BS1-4-141	1/4 X 1	150BKB	HCPK4	4	1
BS1-4-14114	1/4 X 1 1/4	200BKB	HCPK4	4	1
BS1-4-14112	1/4 X 1 1/2	250BKB	HCPK4	4	1
BS1-5-142	1/4 X 2	2 X 150BKB	HCPK4	4	1
BS1-4-381	3/8 X 1	200BKB	HCPK5	4	1
BS1-4-38112	3/8 X 1 1/2	250BKB	HCPK4	4	1
BS1-5-382	3/8 X 2	2 X 200BKB	HCPK5	5	1
BS1-4-121	1/2 X 1	250BKB	HCPK4	4	1
BS1-5-12112	1/2 X 1 1/2	2 X 200BKB	HCPK5	5	1
BS1-5-122	1/2 X 2	2 X 250BKB	HCPK5	5	1

Mold sealing compound (MSC) will be required if surface is uneven.

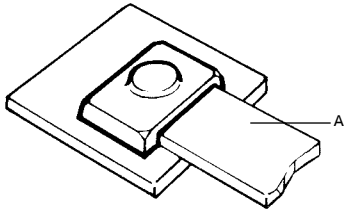

- Rectangular tape or bar

BS2 – For flat surfaces

Cat. no.	Bar size (in.) A	Welding powder size	Handle clamp type	Sleeve	Std. qty.
BS2-4-181	1/8 X 1	115BKB	HCPK4	–	1
BS2-4-18112	1/8 X 1 1/2	150BKB	HCPK4	–	1
BS2-4-182	1/8 X 2	200BKB	HCPK4	–	1
BS2-4-3161	3/16 X 1	150BKB	HCPK4	–	1
BS2-4-316112	3/16 X 1 1/2	200BKB	HCPK4	–	1
BS2-4-3162	3/16 X 2	250BKB	HCPK4	–	1
BS2-4-141	1/4 X 1	150BKB	HCPK4	–	1
BS2-4-14114	1/4 X 1 1/4	200BKB	HCPK4	–	1
BS2-4-14112	1/4 X 1 1/2	250BKB	HCPK4	–	1
BS2-5-142	1/4 X 2	2 X 150BKB	HCPK4	–	1
BS2-4-381	3/8 X 1	200BKB	HCPK5	–	1
BS2-4-38112	3/8 X 1 1/2	250BKB	HCPK4	–	1
BS2-5-382	3/8 X 2	2 X 200BKB	HCPK5	–	1
BS2-4-121	1/2 X 1	250BKB	HCPK4	–	1
BS2-5-12112	1/2 X 1 1/2	2 X 200BKB	HCPK5	–	1
BS2-5-122	1/2 X 2	2 X 250BKB	HCPK5	–	1

Mold sealing compound (MSC) will be required if surface is uneven.

Exothermic welding system

BS3 and BS4 bar to steel surface

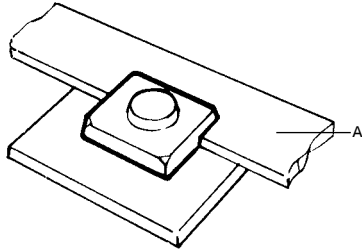

- Rectangular tape or bar

BS3 – For flat surfaces

Cat. no.	Bar size (in.) A	Welding powder size	Handle clamp type	Sleeve	Std. qty.
BS3-4-181	1/8 X 1	115BKB	HCPK4	–	1
BS3-4-18112	1/8 X 1 1/2 and wider	150BKB	HCPK4	–	1
BS3-4-3161	3/16 X 1	150BKB	HCPK4	–	1
BS3-4-316112	3/16 X 1 1/2 and wider	200BKB	HCPK4	–	1
BS3-4-141	1/4 X 1	150BKB	HCPK4	–	1
BS3-4-14114	1/4 X 1-1/4	200BKB	HCPK4	–	1
BS3-4-14112	1/4 X 1 1/2 and wider	250BKB	HCPK4	–	1
BS3-4-381	3/8 X 1	200BKB	HCPK5	–	1
BS3-4-38112	3/8 X 1 1/2 and wider	250BKB	HCPK4	–	1
BS3-4-121	1/2 X 1	250BKB	HCPK4	–	1
BS3-5-12112	1/2 X 1 1/2 and wider	2 X 200BKB	HCPK5	–	1

Mold sealing compound (MSC) will be required if surface is uneven.

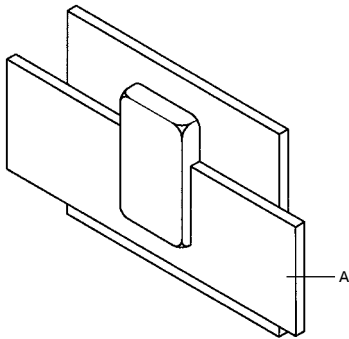

BS4 – For flat surfaces

Cat. no.	Bar size (in.) A	Welding powder size	Handle clamp type	Sleeve	Std. qty.
BS4-4-181	1/8 X 1	115BKB	HCPK4	–	1
BS4-4-18112	1/8 X 1 1/2	150BKB	HCPK4	–	1
BS4-4-182	1/8 X 2	200BKB	HCPK4	–	1
BS4-4-3161	3/16 X 1	150BKB	HCPK4	–	1
BS4-4-316112	3/16 X 1 1/2	200BKB	HCPK4	–	1
BS4-4-3162	3/16 X 2	250BKB	HCPK4	–	1
BS4-4-141	1/4 X 1	150BKB	HCPK4	–	1
BS4-4-14114	1/4 X 1 1/4	200BKB	HCPK4	–	1
BS4-4-14112	1/4 X 1 1/2	250BKB	HCPK4	–	1
BS4-5-142	1/4 X 2	2 X 150BKB	HCPK4	–	1
BS4-4-381	3/8 X 1	200BKB	HCPK5	–	1
BS4-4-38112	3/8 X 1 1/2	250BKB	HCPK4	–	1
BS4-5-382	3/8 X 2	2 X 200BKB	HCPK5	–	1
BS4-4-121	1/2 X 1	250BKB	HCPK4	–	1
BS4-5-12112	1/2 X 1 1/2	2 X 200BKB	HCPK5	–	1
BS4-5-122	1/2 X 2	2 X 250BKB	HCPK5	–	1

Mold sealing compound (MSC) will be required if surface is uneven.

Exothermic welding system

BS5 bar to steel surface

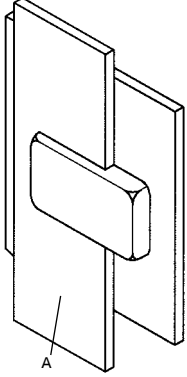

BS5 – For flat surfaces

Cat. no.	Bar size (in.) A	Welding powder size	Handle clamp type	Sleeve	Std. qty.
BS5-4-181	1/8 X 1	115BKB	HCPK4	–	1
BS5-4-18112	1/8 X 1 1/2	150BKB	HCPK4	–	1
BS5-4-182	1/8 X 2 and wider	200BKB	HCPK4	–	1
BS5-4-3161	3/16 X 1	150BKB	HCPK4	–	1
BS5-4-316112	3/16 X 1 1/2	200BKB	HCPK4	–	1
BS5-4-3162	3/16 X 2 and wider	250BKB	HCPK4	–	1
BS5-4-141	1/4 X 1	150BKB	HCPK4	–	1
BS5-4-14114	1/4 X 1 1/4	200BKB	HCPK4	–	1
BS5-4-14112	1/4 X 1 1/2	250BKB	HCPK4	–	1
BS5-5-142	1/4 X 2 and wider	2 X 150BKB	HCPK5	–	1
BS5-4-381	3/8 X 1	200BKB	HCPK5	–	1
BS5-4-38112	3/8 X 1 1/2	250BKB	HCPK4	–	1
BS5-5-382	3/8 X 2 and wider	2 X 200BKB	HCPK5	–	1
BS5-4-121	1/2 X 1	250BKB	HCPK4	–	1
BS5-5-12112	1/2 X 1 1/2	2 X 200BKB	HCPK5	–	1
BS5-5-122	1/2 X 2 and wider	2 X 250BKB	HCPK5	–	1

Mold sealing compound (MSC) will be required if surface is uneven.

Exothermic welding system

Handle clamps, tools and accessories

Handle clamps

Cat. no.	Description	Applications	Std. qty.
HCPK1	Price key 1 handle	For use on price key 1 molds	1
HCPK2	Price key 2 handle	For use on price key 2 molds	1
HCPK3	Price key 3 handle clamp	For use on price key 3 molds	1
HCPK3A	Price key 3A handle clamp	Type 3A molds (connections to vertical rebars)	1
HCPK3B	Price key 3B handle clamp	Type 3B molds (connections to horizontal rebars)	1
HCPK3BMOD	Price key 3B modified clamp	Type 3B molds (cross connections to horizontal rebars)	1
HCPK4	Price key 4 handle clamp	For use on price key 4 molds	1
HCPK5	Price key 5 handle clamp	For use on price key 5 molds	1
HCPK7	Price key 7 handle clamp	For use on price key 7 molds	1
HCPK8	Price key 8 handle clamp	For use on price key 8 molds	1
FRAME1	Price key 9 frame	For use with HCPK4 on price key 9 molds	1
FRAME2	Price key 10 frame	For use with HCPK5 on price key 10 molds	1

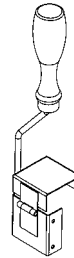

HCPK2

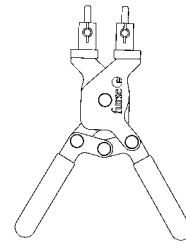

HCPK3

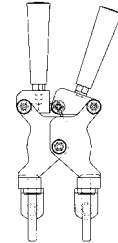

HCPK4

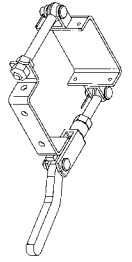

FRAME 1

Tools and accessories

Cat. no.	Description	Applications	Std. qty.
WWB1	Cable cleaning brush	Cleaning of stranded and other circular section conductors	6
WRB1	Replacement elements (pair)	-	3
BFC	Card cloth brush	Cleaning of conductors and surfaces	10
FGUN	Flint ignitor gun	Starting powder ignition	10
BCM	Mold cleaning brush	Soft brush for mold cleaning	10
STM1-TB	Mold scraper tool	Break up and removal of slag in mold crucible	10
MSC	Mold sealing compound	Mold sealing on uneven surfaces, and general mold sealing	5
PACK-A	Packing	Mold sealing on rebar surfaces	50
SLEEVE#6	Sleeve for #6 wire	Prevents burning of small section wire	100
SLEEVE#6S	Sleeve for #6s wire	Prevents burning of small section wire	100
SLEEVE#8	Sleeve for #8 wire	Prevents burning of small section wire	100
SLEEVE#8S	Sleeve for #8s wire	Prevents burning of small section wire	100
SHIM	Copper shim.	For sealing around undersize conductors	100

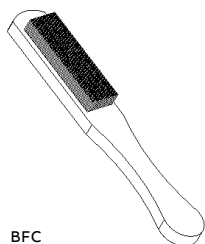

BFC

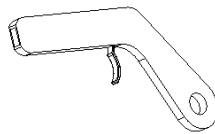

FGUN

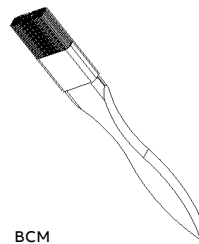

BCM



STM1-TB

Exothermic welding system

Sure Shot™ welding mold



ABB introduces a new approach to the perfect connection, Sure Shot, an extension of the Furseweld line of exothermic welding products.

Sure Shot molds come completely packaged with everything necessary for a connection. They are fast and easy to use. The contractor simply positions the mold, adds the weld powder and starting powder, and ignites it with a flint gun.

Sure Shot molds are disposable, so there's no maintenance involved. And, it's not necessary to remove the mold in underground installations because Sure Shot molds are made from an "earth-friendly" ceramic.

The hexagonal Sure Shot design is easy to grasp and hold without removing safety gloves, and it won't roll away if it's laid down while the installer prepares the connection.

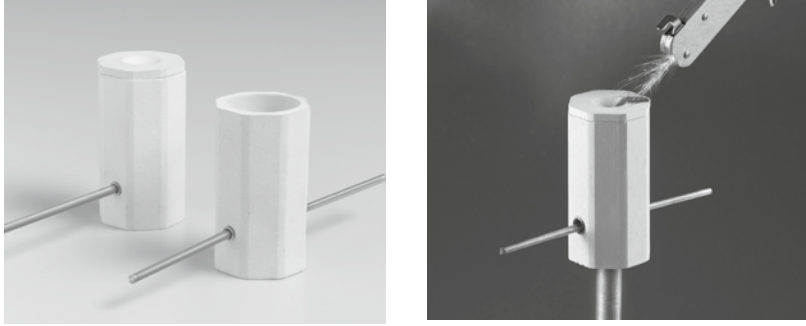
Features and benefits:

- Fast and easy to use
- Packaged with everything necessary for a connection
- Maintenance-free disposable molds
- Made of biodegradable ceramic
- Ergonomic hexagonal design

Diagrams

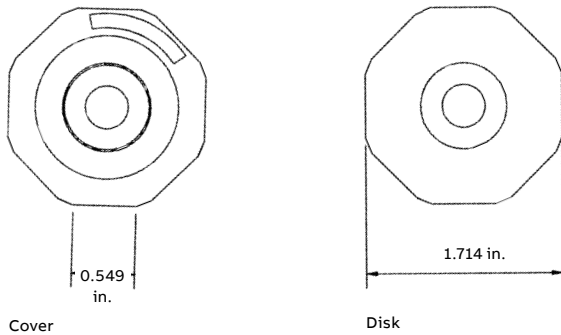

Cover

Disk

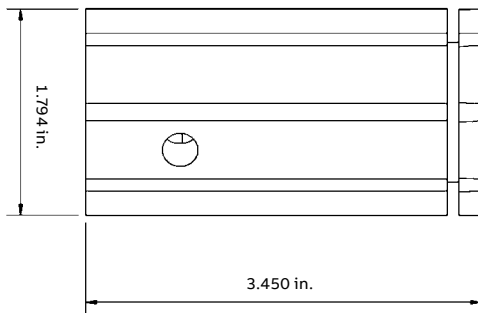

Welding mold

Exothermic welding system

Sure Shot welding mold

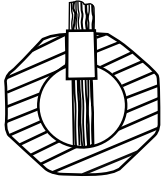

SCR1

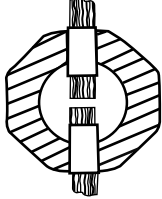

SCR2

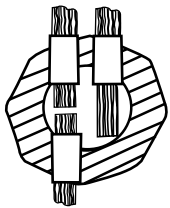

SCR17

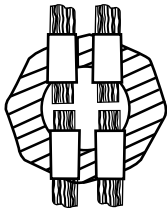

SCR24

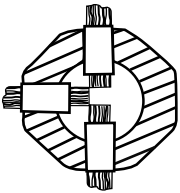

SCR25

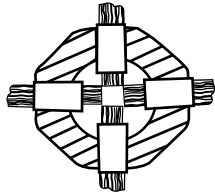

SCR27

Wire positioning

Product specifications

Cat. no.	Ground rod size (in.)	Conductor size (AWG)	
		Solid	Stranded
Furseweld type SCR1			
SCR1-58-2010	5/8	2/0, 1/0	1/0, #1
SCR1-58-0020	5/8	-	2/0
SCR1-34-6808	3/4	#6, 8	#8
SCR1-34-3446	3/4	#3, 4	#4, 6
SCR1-34-1223	3/4	#1, 2	#2, 3
SCR1-34-2010	3/4	2/0, 1/0	1/0, #1
SCR1-34-0020	3/4	-	2/0
SCR1-34-0040	3/4	-	4/0
Furseweld type SCR2			
SCR2-58-3446	5/8	#3, 4	4, 6
SCR2-58-1223	5/8	#1, 2	#2, 3
SCR2-58-0020	5/8	-	2/0
SCR2-34-3446	3/4	#3, 4	#4, 6
SCR2-34-1223	3/4	#1, 2	#2, 3
SCR2-34-0020	3/4	-	2/0
SCR2-34-0040	3/4	-	4/0
Furseweld type SCR17			
SCR17-58-1223	5/8	#1, 2	#2, 3
SCR17-34-6808	3/4	#6, 8	#8
SCR17-34-1223	3/4	#1, 2	#2, 3
Furseweld type SCR24			
SCR24-58-6808	5/8	#6, 8	#8
SCR24-58-3446	5/8	#3, 4	#4, 6
SCR24-58-1223	5/8	#1, 2	#2, 3
SCR24-34-6808	3/4	#6, 8	#8
SCR24-34-3446	3/4	#3, 4	#4, 6
SCR24-34-1223	3/4	#1, 2	#2, 3
Furseweld type SCR25			
SCR25-58-6808	5/8	#6, 8	#8
SCR25-58-3446	5/8	#3, 4	#4, 6
SCR25-34-6808	3/4	#6, 8	#8
SCR25-34-3446	3/4	#3, 4	#4, 6
SCR25-34-1223	3/4	#1, 2	#2, 3
Furseweld type SCR27			
SCR27-58-6808	5/8	#6, 8	#8
SCR27-58-3446	5/8	#3, 4	#4, 6
SCR27-34-6808	3/4	#6, 8	#8
SCR27-34-3446	3/4	#3, 4	#4, 6
SCR27-34-1223	3/4	#1, 2	#2, 3

* The weight per 100 is 20 lb and the standard carton/outer pack is 6 for all catalogue numbers.

Exothermic welding system

Cross reference

Cadweld cat. no.	Thermoweld cat. no.	Furseweld cat. no.
BAC-JE	M-1135	BB1-4-121
BAC-EE	M-1122	BB1-4-141
BAC-EG	M-1124	BB1-4-14112
BAC-EF	M-1123	BB1-4-14114
BAC-EH	M-1125	BB1-4-142
BAC-EJ	M-6346	BB1-4-14212
BAC-CE	M-1118	BB1-4-181
BAC-CG	M-2557	BB1-4-18112
BAC-CH	M-1119	BB1-4-182
BAC-CK	M-6298	BB1-4-183
BAD-CM	M-5315	BB1-4-184
BAC-DE	M-1120	BB1-4-3161
BAC-DH	M-1121	BB1-4-3162
BAC-GE	M-1130	BB1-4-381
BAC-GG	M-1131	BB1-4-38112
BAD-JH	M-1136	BB1-5-122
BAD-EK	M-1126	BB1-5-143
BAD-EM	M-1127	BB1-5-144
BAD-GH	M-1132	BB1-5-382
BAD-GK	M-1133	BB1-5-38
BAD-GM	M-1134	BB1-5-384
EPC-JE	M-1247	BB2-4-121
EPC-EE	M-1234	BB2-4-141
EPC-EG	M-1236	BB2-4-14112
EPC-EF	M-1235	BB2-4-14114
EPC-EH	M-1237	BB2-4-142
EPC-EJ	M-6352	BB2-4-14212
EPC-CE	M-1230	BB2-4-181
EPC-CG	M-6347	BB2-4-18112
EPC-CH	M-1231	BB2-4-182
EPC-CK	M-6348	BB2-4-183
EPD-CM	M-6351	BB2-4-184
EPC-DE	M-1232	BB2-4-3161
EPC-DH	M-1233	BB2-4-3162
EPC-GE	M-1242	BB2-4-381
EPC-GG	M-1243	BB2-4-38112
EPD-JH	M-1248	BB2-5-122
EPD-EK	M-1238	BB2-5-143
EPD-EM	M-1239	BB2-5-144
EPD-GH	M-1244	BB2-5-382
EPD-GK	M-1245	BB2-5-383
EPD-GM	M-1246	BB2-5-384
BQC-EEEE	M-1102	BB3-4-141
BQC-EGEG	M-1104	BB3-4-14112
BQC-EFEF	M-1103	BB3-4-14114
BQC-CECE	M-1098	BB3-4-181
BQC-CHCH	M-1099	BB3-4-182
BQC-DEDE	M-1100	BB3-4-3161
BQC-DHHD	M-1101	BB3-4-3162
BQC-GEGE	M-1108	BB3-4-381
BQD-JEJE	M-1113	BB3-5-121

Cadweld cat. no.	Thermoweld cat. no.	Furseweld cat. no.
BQD-JHJH	M-1114	BB3-5-122
BQD-EHEH	M-1105	BB3-5-142
BQD-GGGG	M-1109	BB3-5-38112
BQD-GHGH	M-1110	BB3-5-382
BQF-EKEK	M-1106	BB3-6-143
BQF-GKGK	M-1111	BB3-6-383
BWC-JE	M-1051	BS1-4-121
BWC-EE	M-1045	BS1-4-141
BWC-EG	M-1047	BS1-4-14112
BWC-EF	M-1046	BS1-4-14114
BWC-CE	M-1043	BS1-4-181
BWC-CG	M-6354	BS1-4-18112
BWC-CH	M-1044	BS1-4-182
BWC-DE	M-6056	BS1-4-3161
BWC-DG	M-6355	BS1-4-316112
BWC-DH	M-6356	BS1-4-3162
BWC-GE	M-1049	BS1-4-381
BWC-GG	M-6357	BS1-4-38112
BWD-JG	M-6358	BS1-5-12112
BWD-JH	M-1052	BS1-5-122
BWD-EH	M-1048	BS1-5-142
BWD-GH	M-1050	BS1-5-382
CGC-JE	M-1084	BS2-4-121
CGC-EE	M-1077	BS2-4-141
CGC-EG	M-1079	BS2-4-14112
CGC-EF	M-1078	BS2-4-14114
CGC-CE	M-1072	BS2-4-181
CGC-CG	M-1073	BS2-4-18112
CGC-CH	M-1074	BS2-4-182
CGC-DE	M-1075	BS2-4-3161
CGC-DG	M-6359	BS2-4-316112
CGC-DH	M-1076	BS2-4-3162
CGC-GE	M-1081	BS2-4-381
CGC-GG	M-1082	BS2-4-38112
CGD-JG	M-1085	BS2-5-12112
CGD-JH	M-1086	BS2-5-122
CGD-EH	M-1080	BS2-5-142
CGD-GH	M-1083	BS2-5-382
CHC-JE	M-1095	BS3-4-121
CHC-EE	M-1090	BS3-4-141
CHC-EG	M-1092	BS3-4-14112
CHC-EF	M-1091	BS3-4-14114
CHC-CE	M-1088	BS3-4-181
CHC-CG	M-1089	BS3-4-18112
CHC-DE	M-6353	BS3-4-3161
CHC-DG	M-7163	BS3-4-316112
CHC-GE	M-1093	BS3-4-381
CHC-GG	M-1094	BS3-4-38112
CHD-JG	M-1096	BS3-5-12112
CCC-JE	M-1060	BS4-4-121
CCC-EE	M-1056	BS4-4-141

Cadweld cat. no.	Thermoweld cat. no.	Furseweld cat. no.
CCC-EG	M-6369	BS4-4-14112
CCC-EF	M-5566	BS4-4-14114
CCC-CE	M-1054	BS4-4-181
CCC-CG	M-6360	BS4-4-18112
CCC-CH	M-1055	BS4-4-182
CCC-DE	M-6361	BS4-4-3161
CCC-DG	M-6362	BS4-4-316112
CCC-DH	M-6367	BS4-4-3162
CCC-GE	M-1058	BS4-4-381
CCC-GG	M-6370	BS4-4-38112
CCD-JG	M-6372	BS4-5-12112
CCD-JH	M-1061	BS4-5-122
CCD-EH	M-1057	BS4-5-142
CCD-GH	M-1059	BS4-5-382
CFC-JE	M-1069	BS5-4-121
CFC-EE	M-1065	BS5-4-141
CFC-EG	M-6379	BS5-4-14112
CFC-EF	M-6377	BS5-4-14114
CFC-CE	M-1063	BS5-4-181
CFC-CF	M-6373	BS5-4-18112
CFC-CH	M-1064	BS5-4-182
CFC-DE	M-6374	BS5-4-3161
CFC-DG	M-6375	BS5-4-316112
CFC-DH	M-6376	BS5-4-3162
CFC-GE	M-1067	BS5-4-381
CFC-GG	M-6382	BS5-4-38112
CFD-JG	M-6383	BS5-5-12112
CFD-JH	M-1070	BS5-5-122
CFD-EH	M-1066	BS5-5-142
CFD-GH	M-1068	BS5-5-382
LAC-1YCE	M-977	CB1-4-#1181
LAC-1VCE	M-975	CB1-4-#2181
LAC-1TCE	-	CB1-4-#2S181
LAC-1LCE	M-971	CB1-4-#4181
LAC-2CEE	M-979	CB1-4-1/0141
LAC-2CCE	M-978	CB1-4-1/0181
LAC-2CDE	M-6075	CB1-4-1/03161
LAC-2GEE	M-981	CB1-4-2/0141
LAC-2GCE	M-980	CB1-4-2/0181
LAC-2GDE	M-6579	CB1-4-2/03161
LAC-2VEE	M-988	CB1-4-250K141
LAC-2VEG	M-990	CB1-4-250K14112
LAC-2VEH	M-8784	CB1-4-250K142
LAC-2VEK	M-1916	CB1-4-250K143
LAC-2VDE	M-8277	CB1-4-250K3161
LAC-2LEE	M-983	CB1-4-3/0141
LAC-2LCE	M-6284	CB1-4-3/0181
LAC-2LDE	M-982	CB1-4-3/03161
LAC-3AEE	M-991	CB1-4-300K141
LAC-3AEG	M-993	CB1-4-300K14112
LAC-3AEH	M-6288	CB1-4-300K142

Exothermic welding system

Cross reference

Cadweld cat. no.	Thermoweld cat. no.	Furseweld cat. no.	Cadweld cat. no.	Thermoweld cat. no.	Furseweld cat. no.	Cadweld cat. no.	Thermoweld cat. no.	Furseweld cat. no.
LAC-3AEK	M-1917	CB1-4-300K143	LJC-JG1V	-	CB4-4-#212112	XBM-2V1Y	M-2718	CC11-7-250K#1
LAC-3DEE	M-994	CB1-4-350K141	LJC-EG1V	-	CB4-4-#214112	XBM-2V1V	M-2719	CC11-7-250K#2
LAC-3DEG	M-996	CB1-4-350K14112	LJC-GG1V	-	CB4-4-#238112	XBM-2V2C	M-2717	CC11-7-250K1/0
LAC-3DEH	M-6289	CB1-4-350K142	LJC-JG1T	-	CB4-4-#2S12112	XBM-2V2G	M-2716	CC11-7-250K2/0
LAC-3DEK	M-1918	CB1-4-350K143	LJC-EG1T	-	CB4-4-#2S14112	XBM-2V2V	M-2713	CC11-7-250K250K
LAC-2QEE	M-985	CB1-4-4/0141	LJC-GG1T	-	CB4-4-#2S38112	XBM-2V2L	M-2715	CC11-7-250K3/0
LAC-2QEG	M-987	CB1-4-4/014112	LJC-JG2C	M-1671	CB4-4-1/012112	XBM-2V2Q	M-2714	CC11-7-250K4/0
LAC-2QEH	M-5657	CB1-4-4/0142	LJC-EG2C	M-1651	CB4-4-1/014112	XBM-2L1Y	M-2705	CC11-7-3/0#1
LAC-2QEK	M-1915	CB1-4-4/0143	LJC-GG2C	M-1660	CB4-4-1/038112	XBM-2L1V	M-2706	CC11-7-3/0#2
LAC-2QDE	M-984	CB1-4-4/03161	LJC-JG2G	M-1672	CB4-4-2/012112	XBM-2L2C	M-2704	CC11-7-3/01/0
LAC-3QEG	M-1001	CB1-4-500K14112	LJC-EG2G	M-1652	CB4-4-2/014112	XBM-2L2G	M-2703	CC11-7-3/02/0
LAC-3QEH	M-1002	CB1-4-500K142	LJC-GG2G	M-1661	CB4-4-2/038112	XBM-2L2L	M-2702	CC11-7-3/03/0
LAC-3QEK	M-1920	CB1-4-500K143	LJC-JG2V	M-1675	CB4-4-250K12112	XBM-3A1Y	M-2726	CC11-7-300K#1
LAC-3QGG	M-1004	CB1-4-500K38112	LJC-EG2V	M-1655	CB4-4-250K14112	XBM-3A1V	M-2727	CC11-7-300K#2
LAD-4YJH	M-1011	CB1-5-1000K122	LJC-GG2V	M-1664	CB4-4-250K38112	XBM-3A2C	M-2725	CC11-7-300K1/0
LAD-4YJK	M-6295	CB1-5-1000K123	LJC-JG2L	M-1673	CB4-4-3/012112	XBM-3A2G	M-2724	CC11-7-300K2/0
LAD-4YEK	M-6292	CB1-5-1000K143	LJC-EG2L	M-1653	CB4-4-3/014112	XBM-3A2L	M-2723	CC11-7-300K3/0
LAD-4YGH	M-1009	CB1-5-1000K382	LJC-GG2L	M-1662	CB4-4-3/038112	XBM-3A2Q	M-2722	CC11-7-300K4/0
LAD-4YGK	M-1922	CB1-5-1000K383	LJC-JG3A	M-1676	CB4-4-300K12112	XBM-3D1Y	M-2735	CC11-7-350K#1
LAD-4LEH	M-1006	CB1-5-750K142	LJC-EG3A	M-1656	CB4-4-300K14112	XBM-3D1V	M-2736	CC11-7-350K#2
LAD-4LEK	M-1921	CB1-5-750K143	LJC-GG3A	M-1665	CB4-4-300K38112	XBM-3D2C	M-2734	CC11-7-350K1/0
LAD-4LGG	M-1007	CB1-5-750K38112	LJC-JG3D	M-1677	CB4-4-350K12112	XBM-3D2G	M-2733	CC11-7-350K2/0
LAD-4LGH	M-1008	CB1-5-750K382	LJC-EG3D	M-1657	CB4-4-350K14112	XBM-2Q1Y	M-2711	CC11-7-4/0#1
LAD-4LGK	M-6291	CB1-5-750K383	LJC-GG3D	M-1666	CB4-4-350K38112	XBM-2Q1V	M-2712	CC11-7-4/0#2
LQJ-JH1Y	-	CB29-10-#1122	LJC-JG2Q	M-1674	CB4-4-4/012112	XBM-2Q2C	M-2710	CC11-7-4/01/0
LQJ-EH1Y	-	CB29-10-#1142	LJC-EG2Q	M-1654	CB4-4-4/014112	XBM-2Q2G	M-2709	CC11-7-4/02/0
LQJ-GH1Y	-	CB29-10-#1382	LJC-GG2Q	M-1663	CB4-4-4/038112	XBM-2Q2L	M-2708	CC11-7-4/03/0
LQJ-JH1V	-	CB29-10-#2122	LJC-EG3Q	M-1659	CB4-4-500K14112	XBM-2Q2Q	M-2707	CC11-7-4/04/0
LQJ-JH1T	-	CB29-10-#2S122	LJC-GG3Q	M-1668	CB4-4-500K38112	XBM-3Q2C	M-2755	CC11-7-500K1/0
LQJ-JH2C	-	CB29-10-1/0122	LJD-JG4Y	M-1681	CB4-5-1000K12112	XBV-3A2V	M-2721	CC11-8-300K250K
LQJ-EH2C	-	CB29-10-1/0142	LJD-GG4Y	M-1670	CB4-5-1000K38112	XBV-3A3A	M-2720	CC11-8-300K300K
LQJ-GH2C	-	CB29-10-1/0382	LJD-JG3Q	M-1679	CB4-5-500K12112	XBV-3D2V	M-2730	CC11-8-350K250K
LQJ-JH2G	-	CB29-10-2/0122	LJD-JG4L	M-1680	CB4-5-750K12112	XBV-3D2L	M-2732	CC11-8-350K3/0
LQJ-EH2G	-	CB29-10-2/0142	LJD-GG4L	M-1669	CB4-5-750K38112	XBV-3D3A	M-2729	CC11-8-350K300K
LQJ-GH2G	-	CB29-10-2/0382	XBC-1Y1Y	M-2691	CC11-7-#1#1	XBV-3D3D	M-2728	CC11-8-350K350K
LQJ-JH2V	-	CB29-10-250K122	XBC-1Y1V	M-2692	CC11-7-#1#2	XBV-3D2Q	M-2731	CC11-8-350K4/0
LQJ-EH2V	-	CB29-10-250K142	XBC-1Y1L	M-2693	CC11-7-#1#4	XBV-3Q2G	M-2754	CC11-8-500K2/0
LQJ-GH2V	-	CB29-10-250K382	XBC-1V1V	M-2689	CC11-7-#2#2	XBV-3Q2V	M-2751	CC11-8-500K250K
LQJ-JH2Q	-	CB29-10-4/0122	XBC-1V1L	M-2690	CC11-7-#2#4	XBV-3Q2L	M-2753	CC11-8-500K3/0
LQJ-EH2Q	-	CB29-10-4/0142	XBC-1T1T	M-2689-S	CC11-7-#2S#2S	XBV-3Q3A	M-2750	CC11-8-500K300K
LQJ-GH2Q	-	CB29-10-4/0382	XBC-1L1L	M-2687	CC11-7-#4#4	XBV-3Q3D	M-2749	CC11-8-500K350K
LQJ-JH3Q	-	CB29-10-500K122	XBP-1H1H	M-5432	CC11-7-#6#6	XBV-3Q2Q	M-2752	CC11-8-500K4/0
LQJ-EH3Q	-	CB29-10-500K142	XBP-1G1G	M-5432-S	CC11-7-#6S#6S	XBV-3Q3Q	M-2747	CC11-8-500K500K
LQJ-GH3Q	-	CB29-10-500K382	XBM-2C1Y	M-2695	CC11-7-1/0#1	SST-1Y	M-5626	CC1-3-#1
LQJ-JH4L	-	CB29-10-750K122	XBM-2C1V	M-2696	CC11-7-1/0#2	SST-1X	M-5626-S	CC1-3-#1S
LQJ-EH4L	-	CB29-10-750K142	XBM-2C1L	M-2697	CC11-7-1/0#4	SST-1V	M-5625	CC1-3-#2
LQJ-GH4L	-	CB29-10-750K382	XBM-2C2C	M-2694	CC11-7-1/01/0	SST-1T	M-5625-S	CC1-3-#2S
LQE-EH1V	-	CB29-9-#2142	XBM-2G1Y	M-2700	CC11-7-2/0#1	SST-1Q	M-5624	CC1-3-#3
LQE-EH1V	-	CB29-9-#2382	XBM-2G1V	M-2701	CC11-7-2/0#2	-	-	CC1-4-#2
LQE-EH1T	-	CB29-9-#2S142	XBM-2G2C	M-2699	CC11-7-2/01/0	SSC-2C	M-205	CC1-4-1/0
LQE-EH1T	-	CB29-9-#2S382	XBM-2G2G	M-2698	CC11-7-2/02/0	SSC-2B	M-205-S	CC1-4-1/0S

Exothermic welding system

Cross reference

Cadweld cat. no.	Thermoweld cat. no.	Furseweld cat. no.
SSC-2G	M-206	CC1-4-2/0
SSC-2V	M-209	CC1-4-250K
SSC-2L	M-207	CC1-4-3/0
SSC-3A	M-210	CC1-4-300K
SSC-3D	M-211	CC1-4-350K
SSC-2Q	M-208	CC1-4-4/0
SSC-2P	M-208-S	CC1-4-4/0S
SSC-3Q	M-213	CC1-4-500K
SSD-4Y	M-215	CC1-5-1000K
SSD-4L	M-214	CC1-5-750K
TAC-1Y1Y	M-225	CC2-4-#1#1
TAC-1Y1V	M-226	CC2-4-#1#2
TAC-1Y1T	M-5879	CC2-4-#1#2S
TAC-1Y1L	M-227	CC2-4-#1#4
TAC-1V1V	M-223	CC2-4-#2#2
TAC-1V1T	M-5869	CC2-4-#2#2S
TAC-1T1L	M-224	CC2-4-#2#4
TAC-1V1L	M-5859	CC2-4-#2#4
TAC-1T1V	M-5856	CC2-4-#2S#2
TAC-1T1T	M-223-S	CC2-4-#2S#2S
TAC-1L1L	M-221	CC2-4-#4#4
TAC-2C1Y	M-229	CC2-4-1/0#1
TAC-2C1V	M-230	CC2-4-1/0#2
TAC-2C1T	M-5311	CC2-4-1/0#2S
TAC-2C1L	M-231	CC2-4-1/0#4
TAC-2C2C	M-228	CC2-4-1/01/0
TAC-4Y2C	M-308	CC2-4-1000K1/0
TAC-4Y2G	M-307	CC2-4-1000K2/0
TAC-4Y2V	M-305	CC2-4-1000K250K
TAC-4Y3A	M-304	CC2-4-1000K300K
TAC-4Y3D	M-303	CC2-4-1000K350K
TAC-4Y2Q	M-306	CC2-4-1000K4/0
TAC-2G1Y	M-234	CC2-4-2/0#1
TAC-2G1V	M-235	CC2-4-2/0#2
TAC-2G1T	M-8093	CC2-4-2/0#2S
TAC-2G1L	M-5475	CC2-4-2/0#4
TAC-2G2C	M-233	CC2-4-2/01/0
TAC-2G2G	M-232	CC2-4-2/02/0
TAC-2V1Y	M-252	CC2-4-250K#1
TAC-2V1V	M-253	CC2-4-250K#2
TAC-2V1T	M-5889	CC2-4-250K#2S
TAC-2V1L	M-5425	CC2-4-250K#4
TAC-2V2C	M-251	CC2-4-250K1/0
TAC-2V2G	M-250	CC2-4-250K2/0
TAC-2V2V	M-247	CC2-4-250K250K
TAC-2V2L	M-249	CC2-4-250K3/0
TAC-2V2Q	M-248	CC2-4-250K4/0
TAC-2L1Y	M-239	CC2-4-3/0#1
TAC-2L1V	M-240	CC2-4-3/0#2
TAC-2L1T	M-5884	CC2-4-3/0#2S
TAC-2L1L	M-5574	CC2-4-3/0#4

Cadweld cat. no.	Thermoweld cat. no.	Furseweld cat. no.
TAC-2L2C	M-238	CC2-4-3/01/0
TAC-2L2G	M-237	CC2-4-3/02/0
TAC-2L2L	M-236	CC2-4-3/03/0
TAC-3A1Y	M-260	CC2-4-300K#1
TAC-3A1V	M-261	CC2-4-300K#2
TAC-3A1T	M-5903	CC2-4-300K#2S
TAC-3A1L	M-6397	CC2-4-300K#4
TAC-3A2C	M-259	CC2-4-300K1/0
TAC-3A2G	M-258	CC2-4-300K2/0
TAC-3A2V	M-255	CC2-4-300K250K
TAC-3A2L	M-257	CC2-4-300K3/0
TAC-3A3A	M-254	CC2-4-300K300K
TAC-3A2Q	M-256	CC2-4-300K4/0
TAC-3D1Y	M-269	CC2-4-350K#1
TAC-3D1V	M-270	CC2-4-350K#2
TAC-3D1L	M-6398	CC2-4-350K#4
TAC-3D2C	M-268	CC2-4-350K1/0
TAC-3D2G	M-267	CC2-4-350K2/0
TAC-3D2V	M-264	CC2-4-350K250K
TAC-3D2L	M-266	CC2-4-350K3/0
TAC-3D3A	M-263	CC2-4-350K300K
TAC-3D3D	M-262	CC2-4-350K350K
TAC-3D2Q	M-265	CC2-4-350K4/0
TAC-2Q1Y	M-245	CC2-4-4/0#1
TAC-2Q1V	M-246	CC2-4-4/0#2
TAC-2Q1T	M-5348	CC2-4-4/0#2S
TAC-2Q1L	M-5021	CC2-4-4/0#4
TAC-2Q2C	M-244	CC2-4-4/01/0
TAC-2Q2G	M-243	CC2-4-4/02/0
TAC-2Q2L	M-242	CC2-4-4/03/0
TAC-2Q2Q	M-241	CC2-4-4/04/0
TAC-3Q1Y	M-288	CC2-4-500K#1
TAC-3Q1V	M-289	CC2-4-500K#2
TAC-3Q1L	M-8113	CC2-4-500K#4
TAC-3Q2C	M-287	CC2-4-500K1/0
TAC-3Q2G	M-286	CC2-4-500K2/0
TAC-3Q2V	M-284	CC2-4-500K250K
TAC-3Q3A	M-283	CC2-4-500K300K
TAC-3Q3D	M-282	CC2-4-500K350K
TAC-3Q2Q	M-285	CC2-4-500K4/0
TAC-3Q3Q	M-280	CC2-4-500K500K
TAC-4L2C	M-298	CC2-4-750K1/0
TAC-4L2G	M-297	CC2-4-750K2/0
TAC-4L2V	M-295	CC2-4-750K250K
TAC-4L3A	M-294	CC2-4-750K300K
TAC-4L3D	M-293	CC2-4-750K350K
TAC-4L2Q	M-296	CC2-4-750K4/0
TAD-4Y4Y	M-299	CC2-5-1000K1000K
TAD-4Y3Q	M-301	CC2-5-1000K500K
TAD-4Y4L	M-300	CC2-5-1000K750K
TAD-4L3Q	M-291	CC2-5-750K500K

Cadweld cat. no.	Thermoweld cat. no.	Furseweld cat. no.
TAD-4L4L	M-290	CC2-5-750K750K
-	-	CC2HD-4-4/04/0
XAC-1Y1Y	M-427	CC4-4-#1#1
XAC-1Y1V	M-428	CC4-4-#1#2
XAC-1Y1L	M-429	CC4-4-#1#4
XAC-1V1V	-	CC4-4-#2#2
XAC-1V1L	-	CC4-4-#2#4
XAC-1T1T	-	CC4-4-#2S#2S
XAC-1L1L	-	CC4-4-#4#4
XAC-2C1Y	M-431	CC4-4-1/0#1
XAC-2C1V	M-432	CC4-4-1/0#2
XAC-2C1L	M-433	CC4-4-1/0#4
XAC-2C2C	M-430	CC4-4-1/01/0
XAC-2G1Y	M-436	CC4-4-2/0#1
XAC-2G1V	M-437	CC4-4-2/0#2
XAC-2G2C	M-435	CC4-4-2/01/0
XAC-2G2G	M-434	CC4-4-2/02/0
XAC-2V1Y	M-454	CC4-4-250K#1
XAC-2V1V	M-455	CC4-4-250K#2
XAC-2V2C	M-453	CC4-4-250K1/0
XAC-2V2G	M-452	CC4-4-250K2/0
XAC-2V2V	M-449	CC4-4-250K250K
XAC-2V2L	M-451	CC4-4-250K3/0
XAC-2V2Q	M-450	CC4-4-250K4/0
XAC-2L1Y	M-441	CC4-4-3/0#1
XAC-2L1V	M-442	CC4-4-3/0#2
XAC-2L2C	M-440	CC4-4-3/01/0
XAC-2L2G	M-439	CC4-4-3/02/0
XAC-2L2L	M-438	CC4-4-3/03/0
XAC-3A1Y	M-462	CC4-4-300K#1
XAC-3A1V	M-463	CC4-4-300K#2
XAC-3A2C	M-461	CC4-4-300K1/0
XAC-3A2G	M-460	CC4-4-300K2/0
XAC-3A2V	M-457	CC4-4-300K250K
XAC-3A2L	M-459	CC4-4-300K3/0
XAC-3A3A	M-456	CC4-4-300K300K
XAC-3A2Q	M-458	CC4-4-300K4/0
XAC-3D1Y	M-471	CC4-4-350K#1
XAC-3D1V	M-472	CC4-4-350K#2
XAC-3D2C	M-470	CC4-4-350K1/0
XAC-3D2G	M-469	CC4-4-350K2/0
XAC-3D2L	M-466	CC4-4-350K250K
XAC-3D2V	M-468	CC4-4-350K3/0
XAC-3D3A	M-465	CC4-4-350K300K
XAC-3D3D	M-464	CC4-4-350K350K
XAC-3D2Q	M-467	CC4-4-350K4/0
XAC-2Q1Y	M-447	CC4-4-4/0#1
XAC-2Q1V	M-448	CC4-4-4/0#2
XAC-2Q2C	M-446	CC4-4-4/01/0
XAC-2Q2G	M-445	CC4-4-4/02/0
XAC-2Q2L	M-444	CC4-4-4/03/0

Exothermic welding system

Cross reference

Cadweld cat. no.	Thermoweld cat. no.	Furseweld cat. no.
XAC-2Q2Q	M-443	CC4-4-4/04/0
XAC-3Q2C	M-491	CC4-4-500K1/0
XAC-3Q2G	M-490	CC4-4-500K2/0
XAD-3Q2V	M-487	CC4-5-500K250K
XAD-3Q2L	M-489	CC4-5-500K3/0
XAD-3Q3A	M-486	CC4-5-500K300K
XAD-3Q3D	M-485	CC4-5-500K350K
XAD-3Q2Q	M-488	CC4-5-500K4/0
XAD-3Q3Q	M-483	CC4-5-500K500K
PCC-1Y1V	M-1282	CC6-4-#1#2
PCC-1Y1L	M-1283	CC6-4-#1#4
PCC-1Y1H	M-1284	CC6-4-#1#6
PCC-1Y1G	M-1285	CC6-4-#1#6S
PCC-1Y1D	M-1286	CC6-4-#1#8S
PCC-1V1V	M-1276	CC6-4-#2#2
PCC-1V1L	M-1277	CC6-4-#2#4
PCC-1V1H	M-1278	CC6-4-#2#6
PCC-1V1G	M-1279	CC6-4-#2#6S
PCC-1V1D	M-1280	CC6-4-#2#8S
PCC-1T1V	-	CC6-4-#2S#2
PCC-1T1T	-	CC6-4-#2S#2S
PCC-1T1H	-	CC6-4-#2S#6
PCC-1T1G	-	CC6-4-#2S#6S
PCC-1T2C	-	CC6-4-#2S1/0
PCC-1T2G	-	CC6-4-#2S2/0
PCC-1L1L	-	CC6-4-#4#4
PCC-1L1H	-	CC6-4-#4#6
PCC-1L1G	-	CC6-4-#4#6S
PCC-1L1D	-	CC6-4-#4#8S
PCC-2C1V	M-1289	CC6-4-1/0#2
PCC-2C1L	M-1290	CC6-4-1/0#4
PCC-2C1H	M-1291	CC6-4-1/0#6
PCC-2C1G	M-1292	CC6-4-1/0#6S
PCC-2C1D	M-1293	CC6-4-1/0#8S
PCC-2G1V	M-1297	CC6-4-2/0#2
PCC-2G1L	M-1298	CC6-4-2/0#4
PCC-2G1H	M-1299	CC6-4-2/0#6
PCC-2G1G	M-1300	CC6-4-2/0#6S
PCC-2G1D	M-1301	CC6-4-2/0#8S
-	-	CC6-4-2/02/0
PCC-2Q1Y	M-1305	CC6-4-4/0#1
PCC-2Q1V	M-1306	CC6-4-4/0#2
PCC-2Q1L	M-1307	CC6-4-4/0#4
PCC-2Q1H	M-1308	CC6-4-4/0#6
PCC-2Q1G	M-1309	CC6-4-4/0#6S
PCC-2Q1D	M-1310	CC6-4-4/0#8S
-	-	CC6-4-4/02/0
-	-	CC6-4-4/04/0
PTC-1Y1Y	M-1315	CC7-4-#1#1
PTC-1Y1X	M-6013	CC7-4-#1#1S
PTC-1Y1V	M-1316	CC7-4-#1#2

Cadweld cat. no.	Thermoweld cat. no.	Furseweld cat. no.
PTC-1Y1T	M-6017	CC7-4-#1#2S
PTC-1Y1L	M-1317	CC7-4-#1#4
PTC-1Y1H	M-5636	CC7-4-#1#6
PTC-1Y1G	M-5637	CC7-4-#1#6S
PTC-1Y1E	M-5638	CC7-4-#1#8
PTC-1Y1D	M-5639	CC7-4-#1#8S
PTC-1X1Y	M-5998	CC7-4-#1S#1
PTC-1X1V	M-6001	CC7-4-#1S#2
PTC-1X1T	M-1316-S	CC7-4-#1S#2S
PTC-1X1L	M-6008	CC7-4-#1S#4
PTC-1X1H	M-6010	CC7-4-#1S#6
PTC-1X1G	M-5636-S	CC7-4-#1S#6S
PTC-1X1E	M-6012	CC7-4-#1S#8
PTC-1X1D	M-5638-S	CC7-4-#1S#8S
PTC-1V1V	M-1313	CC7-4-#2#2
PTC-1V1L	M-1314	CC7-4-#2#4
PTC-1V1H	M-5631	CC7-4-#2#6
PTC-1V1G	M-5632	CC7-4-#2#6S
PTC-1V1E	M-5634	CC7-4-#2#8
PTC-1V1D	M-5635	CC7-4-#2#8S
PTC-1T1V	M-5973	CC7-4-#2S#2
PTC-1T1T	M-1313-S	CC7-4-#2S#2S
PTC-1T1L	M-5987	CC7-4-#2S#4
PTC-1T1H	M-5989	CC7-4-#2S#6
PTC-1T1G	M-5631-S	CC7-4-#2S#6S
PTC-1T1E	M-5993	CC7-4-#2S#8
PTC-1T1D	M-5634-S	CC7-4-#2S#8S
PTC-1L1L	M-1311	CC7-4-#4#4
PTC-1L1H	M-5627	CC7-4-#4#6
PTC-1L1G	M-8882	CC7-4-#4#6S
PTC-1L1E	M-5629	CC7-4-#4#8
PTC-1L1D	M-5630	CC7-4-#4#8S
PTC-2C1Y	M-1319	CC7-4-1/0#1
PTC-2C1X	M-6036	CC7-4-1/0#1S
PTC-2C1V	M-1320	CC7-4-1/0#2
PTC-2C1T	M-6044	CC7-4-1/0#2S
PTC-2C1L	M-1321	CC7-4-1/0#4
PTC-2C1H	M-5642	CC7-4-1/0#6
PTC-2C1G	M-1208	CC7-4-1/0#6S
PTC-2C1E	M-5644	CC7-4-1/0#8
PTC-2C1D	M-5645	CC7-4-1/0#8S
PTC-2C2C	M-1318	CC7-4-1/01/0
PTC-2C2B	M-6035	CC7-4-1/01/0S
PTC-2B1Y	M-6019	CC7-4-1/0S#1
PTC-2B1X	M-1319-S	CC7-4-1/0S#1S
PTC-2B1V	M-6023	CC7-4-1/0S#2
PTC-2B1T	M-1320-S	CC7-4-1/0S#2S
PTC-2B1L	M-6026	CC7-4-1/0S#4
PTC-2B1H	M-6806	CC7-4-1/0S#6
PTC-2B1G	M-5462-S	CC7-4-1/0S#6S
PTC-2B1E	M-6028	CC7-4-1/0S#8

Cadweld cat. no.	Thermoweld cat. no.	Furseweld cat. no.
PTC-2B1D	M-5644-S	CC7-4-1/0S#8S
PTC-2B2C	M-6227	CC7-4-1/0S1/0
PTC-2B2B	M-1318-S	CC7-4-1/0S1/0S
PTC-2G1Y	M-1324	CC7-4-2/0#1
PTC-2G1X	M-6052	CC7-4-2/0#1S
PTC-2G1V	M-1325	CC7-4-2/0#2
PTC-2G1L	M-5659	CC7-4-2/0#4
PTC-2G1H	M-5342	CC7-4-2/0#6
PTC-2G1G	M-5652	CC7-4-2/0#6S
PTC-2G1E	M-5668	CC7-4-2/0#8
PTC-2G1D	M-5943	CC7-4-2/0#8S
PTC-2G2C	M-1323	CC7-4-2/01/0
PTC-2G2B	M-6047	CC7-4-2/01/0S
PTC-2G2G	M-1322	CC7-4-2/02/0
PTC-2L1Y	M-1329	CC7-4-3/0#1
PTC-2L1X	M-6064	CC7-4-3/0#1S
PTC-2L1V	M-1330	CC7-4-3/0#2
PTC-2L1T	M-6065	CC7-4-3/0#2S
PTC-2L1L	M-6046	CC7-4-3/0#4
PTC-2L1H	M-5676	CC7-4-3/0#6
PTC-2L1G	M-5679	CC7-4-3/0#6S
PTC-2L1E	M-5680	CC7-4-3/0#8
PTC-2L1D	M-5682	CC7-4-3/0#8S
PTC-2L2C	M-1328	CC7-4-3/01/0
PTC-2L2B	M-6062	CC7-4-3/01/0S
PTC-2L2G	M-1327	CC7-4-3/02/0
PTC-2L2L	M-1326	CC7-4-3/03/0
PTC-2Q1Y	M-1335	CC7-4-4/0#1
PTC-2Q1X	M-6804	CC7-4-4/0#1S
PTC-2Q1V	M-1336	CC7-4-4/0#2
PTC-2Q1T	M-6805	CC7-4-4/0#2S
PTC-2Q1L	M-5340	CC7-4-4/0#4
PTC-2Q1H	M-5684	CC7-4-4/0#6
PTC-2Q1G	M-6552	CC7-4-4/0#6S
PTC-2Q1E	M-5686	CC7-4-4/0#8
PTC-2Q1D	M-5688	CC7-4-4/0#8S
PTC-2Q2C	M-1334	CC7-4-4/01/0
PTC-2Q2B	M-2551	CC7-4-4/01/0S
PTC-2Q2G	M-1333	CC7-4-4/02/0
PTC-2Q2L	M-1332	CC7-4-4/03/0
PTC-2Q2Q	M-1331	CC7-4-4/04/0
PTC-2Q2P	M-6803	CC7-4-4/04/0S
PTC-2P1Y	M-6089	CC7-4-4/0S#1
PTC-2P1X	M-1335-S	CC7-4-4/0S#1S
PTC-2P1V	M-6090	CC7-4-4/0S#2
PTC-2P1T	M-1336-S	CC7-4-4/0S#2S
PTC-2P1L	M-6109	CC7-4-4/0S#4
PTC-2P1H	M-6111	CC7-4-4/0S#6
PTC-2P1G	M-5684-S	CC7-4-4/0S#6S
PTC-2P1E	M-6112	CC7-4-4/0S#8
PTC-2P1D	M-5686-S	CC7-4-4/0S#8S

Exothermic welding system

Cross reference

Cadweld cat. no.	Thermoweld cat. no.	Furseweld cat. no.
PTC-2P2C	M-6085	CC7-4-4/0S1/0
PTC-2P2B	M-1334-S	CC7-4-4/0S1/0S
PTC-2P2G	M-6082	CC7-4-4/0S2/0
PTC-2P2L	M-6081	CC7-4-4/0S3/0
PTC-2P2Q	M-6071	CC7-4-4/0S4/0
PTC-2P2P	M-1331-S	CC7-4-4/0S4/0S
GRT-14A1V	-	CR1-3-500#2
GRT-14A1T	-	CR1-3-500#2S
GRT-14A1L	M-8403	CR1-3-500#4
GRT-14A1K	M-8403-S	CR1-3-500#4S
GRT-14A1H	M-8402	CR1-3-500#6
GRT-14A1G	M-8402-S	CR1-3-500#6S
GRT-14B1V	-	CR1-3-500L#2
GRT-14B1T	-	CR1-3-500L#2S
GRT-14B1L	M-8403-T	CR1-3-500L#4
GRT-14B1K	M-8403-ST	CR1-3-500L#4S
GRT-14B1H	M-8402-T	CR1-3-500L#6
GRT-14B1G	M-8402-ST	CR1-3-500L#6S
GRT-161L	M-8415	CR1-3-625#4
GRT-161K	M-8415-S	CR1-3-625#4S
GRT-161H	M-8414	CR1-3-625#6
GRT-161G	M-8414-S	CR1-3-625#6S
GRP-181L	M-8426	CR1-3-750#4
GRP-181K	M-8426-S	CR1-3-750#4S
GRT-181H	M-8422	CR1-3-750#6
GRT-181G	M-8422-S	CR1-3-750#6S
GRC-151Y	M-496	CR1-4-500#1
GRC-152C	M-497	CR1-4-5001/0
GRC-152B	M-497-S	CR1-4-5001/0S
GRC-152G	M-498	CR1-4-5002/0
GRC-152V	M-501	CR1-4-500250K
GRC-152L	M-499	CR1-4-5003/0
GRC-153A	M-502	CR1-4-500300K
GRC-152Q	M-500	CR1-4-5004/0
GRC-141Y	M-496-T	CR1-4-500L#1
GRC-142C	M-497-T	CR1-4-500L1/0
GRC-142B	M-497-ST	CR1-4-500L1/0S
GRC-142G	M-498-T	CR1-4-500L2/0
GRC-142V	M-501-T	CR1-4-500L250K
GRC-142L	M-499-T	CR1-4-500L3/0
GRC-143A	M-502-T	CR1-4-500L300K
GRC-142Q	M-500-T	CR1-4-500L4/0
GRC-161Y	M-504	CR1-4-625#1
GRC-161V	M-503	CR1-4-625#2
GRT-161V	-	CR1-4-625#2
GRC-161T	-	CR1-4-625#2S
GRT-161T	-	CR1-4-625#2S
GRC-162C	M-505	CR1-4-6251/0
GRC-162B	M-505-S	CR1-4-6251/0S
GRC-162G	M-506	CR1-4-6252/0
GRC-162V	M-509	CR1-4-625250K

Cadweld cat. no.	Thermoweld cat. no.	Furseweld cat. no.
GRC-162L	M-507	CR1-4-6253/0
GRC-163A	M-510	CR1-4-625300K
GRC-163D	M-511	CR1-4-625350K
GRC-162Q	M-508	CR1-4-6254/0
GRC-163Q	M-513	CR1-4-625500K
GRC-181Y	M-514	CR1-4-750#1
GRC-181V	M-5781	CR1-4-750#2
GRC-181T	-	CR1-4-750#2S
GRC-182C	M-515	CR1-4-7501/0
GRC-182B	M-515-S	CR1-4-7501/0S
GRC-182G	M-516	CR1-4-7502/0
GRC-182V	M-519	CR1-4-750250K
GRC-182L	M-517	CR1-4-7503/0
GRC-183A	M-520	CR1-4-750300K
GRC-183D	M-521	CR1-4-750350K
GRC-182Q	M-518	CR1-4-7504/0
GRC-183Q	M-523	CR1-4-750500K
-	-	CR17-4-7504/0
GTT-14A1L	M-8435	CR2-3-500#4
GTT-14A1K	M-8435-S	CR2-3-500#4S
GTT-14A1H	M-8434	CR2-3-500#6
GTT-14A1G	M-8434-S	CR2-3-500#6S
GTT-14B1L	M-8435-T	CR2-3-500L#4
GTT-14B1K	M-8435-ST	CR2-3-500L#4S
GTT-14B1H	M-8434-T	CR2-3-500L#6
GTT-14B1G	M-8434-ST	CR2-3-500L#6S
GTT-161L	M-8442	CR2-3-625#4
GTT-161K	M-8442-S	CR2-3-625#4S
GTT-161H	M-8441	CR2-3-625#6
GTT-161G	M-8441-S	CR2-3-625#6S
GTP-181L	M-8454	CR2-3-750#4
GTP-181K	M-8454-S	CR2-3-750#4S
GTP-181H	M-8452	CR2-3-750#6
GTP-181G	M-8452-S	CR2-3-750#6S
GTC-151Y	M-538	CR2-4-500#1
GTC-151V	M-537	CR2-4-500#2
GTC-151T	-	CR2-4-500#2S
GTC-152C	M-539	CR2-4-5001/0
GTC-152B	M-539-S	CR2-4-5001/0S
GTC-152G	M-540	CR2-4-5002/0
GTC-152V	M-543	CR2-4-500250K
GTC-152L	M-541	CR2-4-5003/0
GTC-153A	M-544	CR2-4-500300K
GTC-152Q	M-542	CR2-4-5004/0
GTC-141Y	M-538-T	CR2-4-500L#1
GTC-141V	M-537-T	CR2-4-500L#2
GTC-141T	-	CR2-4-500L#2S
GTC-142C	M-539-T	CR2-4-500L1/0
GTC-142B	-	CR2-4-500L1/0S
GTC-142G	M-540-T	CR2-4-500L2/0
GTC-142V	M-543-T	CR2-4-500L250K

Cadweld cat. no.	Thermoweld cat. no.	Furseweld cat. no.
GTC-142L	M-541-T	CR2-4-500L3/0
GTC-143A	M-544-T	CR2-4-500L300K
GTC-142Q	M-542-T	CR2-4-500L4/0
GTC-161Y	M-546	CR2-4-625#1
GTC-161V	M-545	CR2-4-625#2
GTC-161T	-	CR2-4-625#2S
GTC-162C	M-547	CR2-4-6251/0
GTC-162B	M-547-S	CR2-4-6251/0S
GTC-162G	M-548	CR2-4-6252/0
GTC-162V	M-551	CR2-4-625250K
GTC-162L	M-549	CR2-4-6253/0
GTC-163A	M-552	CR2-4-625300K
GTC-163D	M-553	CR2-4-625350K
GTC-162Q	M-550	CR2-4-6254/0
GTC-163Q	M-555	CR2-4-625500K
GTC-181Y	M-557	CR2-4-750#1
GTC-181V	M-556	CR2-4-750#2
GTC-181T	-	CR2-4-750#2S
GTC-182C	M-558	CR2-4-7501/0
GTC-182B	M-558-S	CR2-4-7501/0S
GTC-182G	M-559	CR2-4-7502/0
GTC-182V	M-562	CR2-4-750250K
GTC-182L	M-560	CR2-4-7503/0
GTC-183A	M-563	CR2-4-750300K
GTC-183D	M-564	CR2-4-750350K
GTC-182Q	M-561	CR2-4-7504/0
GTC-183Q	M-566	CR2-4-750500K
GYJ-163Q	M-1593	CR3-10-625500K
GYJ-183D	M-1599	CR3-10-750350K
GYJ-183Q	M-1601	CR3-10-750500K
GYE-152C	M-1581	CR3-9-5001/0
GYE-152B	M-1581-S	CR3-9-5001/0S
GYE-152G	M-1582	CR3-9-5002/0
GYE-152V	M-1584	CR3-9-500250K
GYE-152L	M-6267	CR3-9-5003/0
GYE-153A	M-1585	CR3-9-500300K
GYE-152Q	M-1583	CR3-9-5004/0
GYE-142C	M-1581-T	CR3-9-500L1/0
GYE-142B	M-1581-ST	CR3-9-500L1/0S
GYE-142G	M-1582-T	CR3-9-500L2/0
GYE-142V	M-1584-T	CR3-9-500L250K
GYE-142L	M-6267-T	CR3-9-500L3/0
GYE-143A	M-1585-T	CR3-9-500L300K
GYE-142Q	M-1583-T	CR3-9-500L4/0
-	-	CR3-9-625#2
GYE-162C	M-1586	CR3-9-6251/0
GYE-162B	M-1586-S	CR3-9-6251/0S
GYE-162G	M-1587	CR3-9-6252/0
GYE-162V	M-1589	CR3-9-625250K
GYE-162L	M-8305	CR3-9-6253/0
GYE-163A	M-1590	CR3-9-625300K

Exothermic welding system

Cross reference

Cadweld cat. no.	Thermoweld cat. no.	Furseweld cat. no.	Cadweld cat. no.	Thermoweld cat. no.	Furseweld cat. no.	Cadweld cat. no.	Thermoweld cat. no.	Furseweld cat. no.
GYE-163D	M-1591	CR3-9-625350K	RC	-	CRE3-4-4/OY	VBC-1Y	M-5361	CS25-4-#1
GYE-162Q	M-1588	CR3-9-6254/0	RC	-	CRE3-4-4/OZ	VBC-1Y-V3	-	CS25-4-#1C
GYE-182C	M-1594	CR3-9-7501/0	RD	-	CRE4-3-#1Y	VBC-1Y-V5	-	CS25-4-#1D
GYE-182B	M-1594-S	CR3-9-7501/0S	RD	-	CRE4-3-#1Z	VBC-1Y-V8	-	CS25-4-#1F
GYE-182G	M-1595	CR3-9-7502/0	RD	-	CRE4-3-#2SY	VBC-1Y-V21C	-	CS25-4-#1G
GYE-182V	M-1597	CR3-9-750250K	RD	-	CRE4-3-#2SZ	VBC-1V	M-2781	CS25-4-#2
GYE-182L	M-6608	CR3-9-7503/0	RD	-	CRE4-3-#2Y	VBC-1V-V3	-	CS25-4-#2C
GYE-183A	-	CR3-9-750300K	RD	-	CRE4-3-#2Z	VBC-1V-V5	-	CS25-4-#2D
GYE-182Q	M-1596	CR3-9-7504/0	RD	-	CRE4-3-#4Y	VBC-1V-V8	-	CS25-4-#2F
RR	-	CRE1-3-#1Y	RD	-	CRE4-3-#4Z	VBC-1V-V21C	-	CS25-4-#2G
RR	-	CRE1-3-#1Z	RD	-	CRE4-3-1/OY	VBC-1T	-	CS25-4-#2S
RR	-	CRE1-3-#2SY	RD	-	CRE4-3-1/OZ	VBC-1T-V3	-	CS25-4-#2SC
RR	-	CRE1-3-#2SZ	RD	-	CRE4-3-2/OY	VBC-1T-V5	-	CS25-4-#2SD
RR	-	CRE1-3-#2Y	RD	-	CRE4-3-2/OZ	VBC-1T-V8	-	CS25-4-#2SF
RR	-	CRE1-3-#2Z	RD	-	CRE4-3-3/OY	VBC-1T-V21	-	CS25-4-#2SG
RR	-	CRE1-3-#4Y	RD	-	CRE4-3-3/OZ	VBC-1L	M-5359	CS25-4-#4
RR	-	CRE1-3-#4Z	RD	-	CRE4-3-4/OY	VBC-1L-V3	-	CS25-4-#4C
RR	-	CRE1-3-1/OY	RD	-	CRE4-3-4/OZ	VBC-1L-V5	-	CS25-4-#4D
RR	-	CRE1-3-1/OZ	RJ	-	CRE6-3-#1Y	VBC-1L-V8	-	CS25-4-#4F
RR	-	CRE1-3-2/OY	RJ	-	CRE6-3-#1Z	VBC-1L-V21	-	CS25-4-#4G
RR	-	CRE1-3-2/OZ	RJ	-	CRE6-3-#2SY	VBC-2C	M-2189	CS25-4-1/0
RR	-	CRE1-3-3/OY	RJ	-	CRE6-3-#2SZ	VBC-2C-V3	-	CS25-4-1/0C
RR	-	CRE1-3-3/OZ	RJ	-	CRE6-3-#2Y	VBC-2C-V5	-	CS25-4-1/0D
RR	-	CRE1-3-4/OY	RJ	-	CRE6-3-#2Z	VBC-2C-V8	-	CS25-4-1/0F
RR	-	CRE1-3-4/OZ	RJ	-	CRE6-3-#4Y	VBC-2C-V20	-	CS25-4-1/0G
RRC-511Y	M-7503	CRE1-4-#13R	RJ	-	CRE6-3-#4Z	VBC-2G	M-2540	CS25-4-2/0
RRC-511V	M-7502	CRE1-4-#23R	RJ	-	CRE6-4-1/OY	VBC-2G-V3	-	CS25-4-2/0C
RRC-511T	-	CRE1-4-#253R	RJ	-	CRE6-4-1/OZ	VBC-2G-V5	-	CS25-4-2/0D
RRC-511L	M-7501	CRE1-4-#43R	RJ	-	CRE6-4-2/OY	VBC-2G-V8	-	CS25-4-2/0F
RRC-512C	M-7504	CRE1-4-1/03R	RJ	-	CRE6-4-2/OZ	VBC-2G-V20	-	CS25-4-2/0G
RRC-512G	M-7505	CRE1-4-2/03R	RJ	-	CRE6-4-3/OY	VBC-2V	M-8165	CS25-4-250K
RRC-512L	M-7506	CRE1-4-3/03R	RJ	-	CRE6-4-3/OZ	VBC-2L	M-5362	CS25-4-3/0
RRC-512Q	M-7507	CRE1-4-4/03R	RJ	-	CRE6-4-4/OY	VBC-2L-V3	-	CS25-4-3/0C
RC	-	CRE3-3-#2SY	RJ	-	CRE6-4-4/OZ	VBC-2L-V5	-	CS25-4-3/0D
RC	-	CRE3-3-#2SZ	HSC-2C	M-644	CS1-4-1/0	VBC-2L-V8	-	CS25-4-3/0F
RC	-	CRE3-3-#2Y	HSD-4Y	M-654	CS1-4-1000K	VBC-2L-V20	-	CS25-4-3/0G
RC	-	CRE3-3-#2Z	HSC-2G	M-645	CS1-4-2/0	VBC-3A	M-5363	CS25-4-300K
RC	-	CRE3-3-#4Y	HSC-2V	M-648	CS1-4-250K	VBC-3D	M-9029	CS25-4-350K
RC	-	CRE3-3-#4Z	HSC-2L	M-646	CS1-4-3/0	VBC-2Q	M-8718	CS25-4-4/0
-	-	CRE3-3-1/OY	HSC-3A	M-649	CS1-4-300K	VBC-2Q-V3	-	CS25-4-4/0C
-	-	CRE3-3-1/OZ	HSC-3D	M-650	CS1-4-350K	VBC-2Q-V5	-	CS25-4-4/0D
-	-	CRE3-3-2/OY	HSC-2Q	M-647	CS1-4-4/0	VBC-2Q-V8	-	CS25-4-4/0F
-	-	CRE3-3-2/OZ	HSC-3Q	M-652	CS1-4-500K	VBC-2Q-V20	-	CS25-4-4/0G
RC	-	CRE3-4-#1Y	HSD-4L	M-653	CS1-4-750K	VBR-3Q	M-8512	CS25-4-500K
RC	-	CRE3-4-#1Z	HTC-2C	M-616	CS2-4-1/0	HTD-3Q	M-624	CS2-5-500K
RC	-	CRE3-4-1/OY	HTC-2G	M-617	CS2-4-2/0	VGC-1Y	M-6279	CS27-4-#1
RC	-	CRE3-4-1/OZ	HTC-2V	M-620	CS2-4-250K	VGC-1Y-V3	-	CS27-4-#1C
RC	-	CRE3-4-2/OY	HTC-2L	M-618	CS2-4-3/0	VGC-1Y-V5	-	CS27-4-#1D
RC	-	CRE3-4-2/OZ	HTC-3A	M-621	CS2-4-300K	VGC-1Y-V8	-	CS27-4-#1F
RC	-	CRE3-4-3/OY	HTC-3D	M-622	CS2-4-350K	VGC-1Y-V21C	-	CS27-4-#1G
RC	-	CRE3-4-3/OZ	HTC-2Q	M-619	CS2-4-4/0	VGC-1V	M-5822	CS27-4-#2

Exothermic welding system

Cross reference

Cadweld cat. no.	Thermoweld cat. no.	Furseweld cat. no.
VGC-1V-V3	-	CS27-4-#2C
VGC-1V-V5	-	CS27-4-#2D
VGC-1V-V8	-	CS27-4-#2F
VGC-1V-V21C	-	CS27-4-#2G
VGC-1T	-	CS27-4-#2S
VGC-1T-V3	-	CS27-4-#2SC
VGC-1T-V5	-	CS27-4-#2SD
VGC-1T-V8	-	CS27-4-#2SF
VGC-1T-V21	-	CS27-4-#2SG
VGC-1H	M-5245	CS27-4-#4
VGC-1L	M-5816	CS27-4-#4
VGC-1L-V3	-	CS27-4-#4C
VGC-1L-V5	-	CS27-4-#4D
VGC-1L-V8	-	CS27-4-#4F
VGC-1L-V21	-	CS27-4-#4G
VGC-2C	M-1168	CS27-4-1/0
VGC-2C-V3	-	CS27-4-1/0C
VGC-2C-V5	-	CS27-4-1/0D
VGC-2C-V8	-	CS27-4-1/0F
VGC-2C-V20	-	CS27-4-1/0G
VGC-2G	M-9242	CS27-4-2/0
VGC-2G-V3	-	CS27-4-2/0C
VGC-2G-V5	-	CS27-4-2/0D
VGC-2G-V8	-	CS27-4-2/0F
VGC-2G-V20	-	CS27-4-2/0G
VGC-2V	M-2520	CS27-4-250K
VGC-2L	M-6195	CS27-4-3/0
VGC-2L-V3	-	CS27-4-3/0C
VGC-2L-V5	-	CS27-4-3/0D
VGC-2L-V8	-	CS27-4-3/0F
VGC-2L-V20	-	CS27-4-3/0G
VGC-2Q	M-2177	CS27-4-4/0
VGC-2Q-V3	-	CS27-4-4/0C
VGC-2Q-V5	-	CS27-4-4/0D
VGC-2Q-V8	-	CS27-4-4/0F
VGC-2Q-V20	-	CS27-4-4/0G
VNC-1Y	M-6060	CS31-4-#1
VGC-1Y-V3	-	CS31-4-#1C
VGC-1Y-V5	-	CS31-4-#1D
VGC-1Y-V8	-	CS31-4-#1F
VGC-1Y-V21C	-	CS31-4-#1G
VNC-1V	M-2569	CS31-4-#2
VGC-1V-V3	-	CS31-4-#2C
VGC-1V-V5	-	CS31-4-#2D
VGC-1V-V8	-	CS31-4-#2F
VGC-1V-V21C	-	CS31-4-#2G
VNC-1T	-	CS31-4-#2S
VGC-1T-V3	-	CS31-4-#2SC
VGC-1T-V5	-	CS31-4-#2SD
VGC-1T-V8	-	CS31-4-#2SF
VGC-1T-V21	-	CS31-4-#2SG

Cadweld cat. no.	Thermoweld cat. no.	Furseweld cat. no.
VNC-1L	M-2761	CS31-4-#4
VGC-1L-V3	-	CS31-4-#4C
VGC-1L-V5	-	CS31-4-#4D
VGC-1L-V8	-	CS31-4-#4F
VGC-1L-V21	-	CS31-4-#4G
VNC-1H	M-5910	CS31-4-#6
VNC-2C	M-5419	CS31-4-1/0
VGC-2C-V3	-	CS31-4-1/0C
VGC-2C-V5	-	CS31-4-1/0D
VGC-2C-V8	-	CS31-4-1/0F
VGC-2C-V20	-	CS31-4-1/0G
VNC-2G	M-2567	CS31-4-2/0
VGC-2G-V3	-	CS31-4-2/0C
VGC-2G-V5	-	CS31-4-2/0D
VGC-2G-V8	-	CS31-4-2/0F
VGC-2G-V20	-	CS31-4-2/0G
VNC-2V	M-2568	CS31-4-250K
VNC-2L	M-6072	CS31-4-3/0
VGC-2L-V3	-	CS31-4-3/0C
VGC-2L-V5	-	CS31-4-3/0D
VGC-2L-V8	-	CS31-4-3/0F
VGC-2L-V20	-	CS31-4-3/0G
VNC-3A	M-6061	CS31-4-300K
VNC-3D	M-6067	CS31-4-350K
VNC-2Q	M-9253	CS31-4-4/0
VGC-2Q-V3	-	CS31-4-4/0C
VGC-2Q-V5	-	CS31-4-4/0D
VGC-2Q-V8	-	CS31-4-4/0F
VGC-2Q-V20	-	CS31-4-4/0G
VNC-3Q	M-8359	CS31-4-500K
HAA-1Y-325C	M-6269	CS32-2-#1D
HAA-1Y-7C	M-6270	CS32-2-#1F
HAA-1Y-11C	M-6271	CS32-2-#1G
HAA-1V-162C	M-6016	CS32-2-#2C
HAA-1V-350C	M-2576	CS32-2-#2D
HAA-1V-7C	M-2514	CS32-2-#2F
HAA-1V-11C	M-2515	CS32-2-#2G
HAA-1T-162C	-	CS32-2-#2SC
HAA-1T-350C	-	CS32-2-#2SD
HAA-1T-7C	-	CS32-2-#2SF
HAA-1T-11C	-	CS32-2-#2SG
HAA-1L-162C	M-8014	CS32-2-#4C
HAA-1L-350C	M-8015	CS32-2-#4D
HAA-1L-7C	M-2516	CS32-2-#4F
HAA-1L-11C	M-2517	CS32-2-#4G
HAH-2C-350C	M-8504	CS32-4-1/0D
HAH-2C-8C	M-8505	CS32-4-1/0F
HAH-2C-20C	M-6272	CS32-4-1/0G
HAH-2G-350C	M-2776	CS32-4-2/0D
HAH-2G-8C	M-6273	CS32-4-2/0F
HAH-2G-20C	M-6274	CS32-4-2/0G

Cadweld cat. no.	Thermoweld cat. no.	Furseweld cat. no.
HAH-2L-350C	M-6275	CS32-4-3/0D
HAH-2L-8C	M-6276	CS32-4-3/0F
HAH-2L-20C	M-6278	CS32-4-3/0G
HAH-2Q-350C	M-9236	CS32-4-4/0D
HAH-2Q-8C	M-9237	CS32-4-4/0F
HAH-2Q-20C	M-9238	CS32-4-4/0G
VSC-1Y	M-589	CS3-4-#1
VSC-1Y-V3C	M-2482	CS3-4-#1C
VSC-1Y-V5C	M-2483	CS3-4-#1D
VSC-1Y-V8C	M-2484	CS3-4-#1F
VSC-1Y-V21C	M-2485	CS3-4-#1G
VSC-1V	M-588	CS3-4-#2
VSC-1V-V3C	M-9233	CS3-4-#2C
VSC-1V-V5C	M-2480	CS3-4-#2D
VSC-1V-V8C	M-2583	CS3-4-#2F
VSC-1V-V21C	M-2481	CS3-4-#2G
VSC-1T	-	CS3-4-#2S
VSC-1T-V3C	-	CS3-4-#2SC
VSC-1T-V5C	-	CS3-4-#2SD
VSC-1T-V8C	-	CS3-4-#2SF
VSC-1T-V21C	-	CS3-4-#2SG
VSC-1L	M-586	CS3-4-#4
VSC-1L-V3C	M-2476	CS3-4-#4C
VSC-1L-V5C	M-2477	CS3-4-#4D
VSC-1L-V8C	M-2478	CS3-4-#4F
VSC-1L-V21C	M-2479	CS3-4-#4G
VSC-1H	M-585	CS3-4-#6
VSC-2C	M-590	CS3-4-1/0
VSC-2C-V3C	M-2486	CS3-4-1/0C
VSC-2C-V5C	M-2487	CS3-4-1/0D
VSC-2C-V8C	M-2488	CS3-4-1/0F
VSC-2C-V21C	M-2489	CS3-4-1/0G
HCA-1Y-350C	-	CS34-2-#1D
HCA-1Y-7C	-	CS34-2-#1F
HCA-1Y-11C	-	CS34-2-#1G
HCA-1V-162C	-	CS34-2-#2C
HCA-1V-350C	-	CS34-2-#2D
HCA-1V-7C	-	CS34-2-#2F
HCA-1V-11C	-	CS34-2-#2G
HCA-1T-162C	-	CS34-2-#2SC
HCA-1T-350C	-	CS34-2-#2SD
HCA-1T-7C	-	CS34-2-#2SF
HCA-1T-11C	-	CS34-2-#2SG
HCA-1L-162C	-	CS34-2-#4C
HCA-1L-350C	-	CS34-2-#4D
HCA-1L-7C	-	CS34-2-#4F
HCA-1L-11C	-	CS34-2-#4G
VSC-2G	M-591	CS3-4-2/0
VSC-2G-V3C	M-8833	CS3-4-2/0C
VSC-2G-V5C	M-2490	CS3-4-2/0D
VSC-2G-V8C	M-2491	CS3-4-2/0F

Exothermic welding system

Cross reference

Cadweld cat. no.	Thermoweld cat. no.	Furseweld cat. no.	Cadweld cat. no.	Thermoweld cat. no.	Furseweld cat. no.	Cadweld cat. no.	Thermoweld cat. no.	Furseweld cat. no.
VSC-2G-V21C	M-2492	CS3-4-2/0G	VVR-2C-V3	-	CS4-5-1/0C	VFR-2L	M-1642	CS7-5-3/0
VSC-2V	M-594	CS3-4-250K	VVR-2C-V5	-	CS4-5-1/0D	VFR-2L-V3	-	CS7-5-3/0C
VSC-2L	M-592	CS3-4-3/0	VVR-2C-V8	-	CS4-5-1/0F	VFR-2L-V5	-	CS7-5-3/0D
VSC-2L-V3C	M-2493	CS3-4-3/0C	VVR-2C-V20	-	CS4-5-1/0G	VFR-2L-V8	-	CS7-5-3/0F
VSC-2L-V5C	M-2494	CS3-4-3/0D	VVR-2G	M-1221	CS4-5-2/0	VFR-2L-V20	-	CS7-5-3/0G
VSC-2L-V8C	M-2495	CS3-4-3/0F	VVR-2G-V3	-	CS4-5-2/0C	VFR-3A	M-1645	CS7-5-300K
VSC-2L-V21C	M-2496	CS3-4-3/0G	VVR-2G-V5	-	CS4-5-2/0D	VFR-2Q	M-1643	CS7-5-4/0
VSC-3A	M-595	CS3-4-300K	VVR-2G-V8	-	CS4-5-2/0F	VFR-2Q-V3	-	CS7-5-4/0C
VSC-3D	M-596	CS3-4-350K	VVR-2G-V20	-	CS4-5-2/0G	VFR-2Q-V5	-	CS7-5-4/0D
VSC-2Q	M-593	CS3-4-4/0	VVR-2V	M-1224	CS4-5-250K	VFR-2Q-V8	-	CS7-5-4/0F
VSC-2Q-V3C	M-9021	CS3-4-4/0C	VVR-2L	M-1222	CS4-5-3/0	VFR-2Q-V20	-	CS7-5-4/0G
VSC-2Q-V5C	M-2497	CS3-4-4/0D	VVR-2L-V3	-	CS4-5-3/0C	VFF-3D	M-1646	CS7-6-350K
VSC-2Q-V8C	M-2498	CS3-4-4/0F	VVR-2L-V5	-	CS4-5-3/0D	VFF-3Q	M-1648	CS7-6-500K
VSC-2Q-V21C	M-2499	CS3-4-4/0G	VVR-2L-V8	-	CS4-5-3/0F	HAA-1Y	M-631	CS8-2-#1
HTC-2C-350C	-	CS34-4-1/0D	VVR-2L-V20	-	CS4-5-3/0G	HAA-1V	M-630	CS8-2-#2
HTC-2C-8C	-	CS34-4-1/0F	VVR-2Q	M-1223	CS4-5-4/0	HAA-1T	-	CS8-2-#2S
HTC-2C-20C	-	CS34-4-1/0G	VVR-2Q-V3	-	CS4-5-4/0C	HAA-1L	M-629	CS8-2-#4
HTC-2G-350C	-	CS34-4-2/0D	VVR-2Q-V5	-	CS4-5-4/0D	HAA-1H	M-628	CS8-2-#6
HTC-2G-8C	-	CS34-4-2/0F	VVR-2QV8	-	CS4-5-4/0F	HCA-1Y	M-605	CS9-2-#1
HTC-2G-20C	-	CS34-4-2/0G	VVR-2Q-V20	-	CS4-5-4/0G	HCA-1V	M-604	CS9-2-#2
HTC-2L-350C	-	CS34-4-3/0D	VFC-1Y	M-1639	CS7-4-#1	HCA-1T	-	CS9-2-#2S
HTC-2L-8C	-	CS34-4-3/0F	VFC-1Y-V3	-	CS7-4-#1C	HCA-1L	M-603	CS9-2-#4
HTC-2L-20C	-	CS34-4-3/0G	VFC-1Y-V5	-	CS7-4-#1D	HCA-1H	M-602	CS9-2-#6
HTC-2Q-350C	-	CS34-4-4/0D	VFC-1Y-V8	-	CS7-4-#1F	15	15	15BKB
HTC-2Q-8C	-	CS34-4-4/0F	VFC-1Y-V21	-	CS7-4-#1G	25	25	25BKB
HTC-2Q-20C	-	CS34-4-4/0G	VFC-1V	M-1638	CS7-4-#2	32	32	32BKB
VSC-3Q	M-598	CS3-4-500K	VFC-1V-V3	-	CS7-4-#2C	45	45	45BKB
VSD-4Y	M-600	CS3-5-1000K	VFC-1V-V5	-	CS7-4-#2D	65	65	65BKB
VSD-4L	M-599	CS3-5-750K	VFC-1V-V8	-	CS7-4-#2F	90	90	90BKB
VVC-1Y	M-1219	CS4-4-#1	VFC-1V-V21	-	CS7-4-#2G	115	115	115BKB
VVC-1Y-V3	-	CS4-4-#1C	VFC-1T	-	CS7-4-#2S	150	150	150BKB
VVC-1Y-V5	-	CS4-4-#1D	VFC-1T-V3	-	CS7-4-#2SC	200	200	200BKB
VVC-1Y-V8	-	CS4-4-#1F	VFC-1T-V5	-	CS7-4-#2SD	250	250	250BKB
VVC-1Y-V21	-	CS4-4-#1G	VFC-1T-V8	-	CS7-4-#2SF	L160	40-0106-00	HCPK4
VVC-1V	M-1218	CS4-4-#2	VFC-1T-V21	-	CS7-4-#2SG	L159	40-0107-00	HCPK5
VVC-1V-V3	-	CS4-4-#2C	VFC-1L	M-1636	CS7-4-#4	T314	38-0135-00	WWB1
VVC-1V-V5	-	CS4-4-#2D	VFC-1L-V3	-	CS7-4-#4C	T314A	38-0135-01	WRB1
VVC-1V-V8	-	CS4-4-#2F	VFC-1L-V5	-	CS7-4-#4D	T313	38-0306-00	BFC
VVC-1V-V21	-	CS4-4-#2G	VFC-1L-V8	-	CS7-4-#4F	T320	38-0309-00	FGUN
VVC-1T	-	CS4-4-#2S	VFC-1L-V21	-	CS7-4-#4G	T394	38-3922-00	BCM
VVC-1T-V3	-	CS4-4-#2SC	VFC-2C	M-1640	CS7-4-1/0	B136A/B	40-0319-01/3/5/6	STM1
VVC-1T-V5	-	CS4-4-#2SD	VFC-2C-V3	-	CS7-4-1/0C	T403	38-4129-00	MSC
VVC-1T-V8	-	CS4-4-#2SF	VFC-2C-V5	-	CS7-4-1/0D	B144A/B/C/E	38-406-1/2/3/4-00	PACK-A
VVC-1T-V21	-	CS4-4-#2SG	VFC-2C-V8	-	CS7-4-1/0F			
VVC-1L	M-1216	CS4-4-#4	VFC-2C-V20	-	CS7-4-1/0G			
VVC-1L-V3	-	CS4-4-#4C	VFC-2G	M-1641	CS7-4-2/0			
VVC-1L-V5	-	CS4-4-#4D	VFC-2G-V3	-	CS7-4-2/0C			
VVC-1L-V8	-	CS4-4-#4F	VFC-2G-V5	-	CS7-4-2/0D			
VVC-1L-V21	-	CS4-4-#4G	VFC-2G-V8	-	CS7-4-2/0F			
VVC-1H	M-1215	CS4-4-#6	VFC-2G-V20	-	CS7-4-2/0G			
VVR-2C	M-1220	CS4-5-1/0	VFR-2V	M-1644	CS7-5-250K			

Exothermic welding system

Sure Shot cross reference

Ground rod Size (in.)	Conductor size (AWG or kcmil)		Cadweld cat. no.	Thermoweld cat. no.	Furseweld cat. no.
	Solid	Stranded	TYPE GR(CR1)	TYPE CR-1	TYPE CR1
½	#6, 8	#8	GR1-141G	-	-
	#3, 4	#4, 6	GR1-141L	-	-
	#1, 2	#2, 3	GR1-141V	-	-
⅝	#6, 8	#8	GR1-161G	M-2012	SCR1-58-6808
	#3, 4	#4, 6	GR1-161L	M-2013	SCR1-58-3446
	#1, 2	#2, 3	GR1-161V	M-2014	SCR1-58-1223
	2/0, 1/0	1/0, #1	GR1-162C	M-2015	SCR1-58-2010
	-	2/0	GR1-162G	M-2016	SCR1-58-0020
¾	#6, 8	#8	GR1-181G	M-2017	SCR1-34-6808
	#3, 4	#4, 6	GR1-181L	M-2018	SCR1-34-3446
	#1, 2	#2, 3	GR1-181V	M-2019	SCR1-34-1223
	2/0, 1/0	1/0, #1	GR1-182C	M-2020	SCR1-34-2010
	-	2/0	GR1-182G	M-2021	SCR1-34-0020
	-	4/0	GR1-182Q	-	SCR1-34-0040
Size (in.)	Solid	Stranded	TYPE GT(CR2)	TYPE CR-2	TYPE CR2
½	#6, 8	#8	GT1-141G	-	-
	#3, 4	#4, 6	GT1-141L	-	-
	#1, 2	#2, 3	GT1-141V	-	-
⅝	#6, 8	#8	GT1-161G	M-2027	SCR2-58-6808
	#3, 4	#4, 6	GT1-161L	M-2028	SCR2-58-3446
	#1, 2	#2, 3	GT1-161V	M-2029	SCR2-58-1223
	2/0, 1/0	1/0, #1	GT1-162C	M-2030	SCR2-58-2010
	-	2/0	-	-	SCR2-58-0020*
¾	#6, 8	#8	GT1-181G	M-2031	SCR2-34-6808
	#3, 4	#4, 6	GT1-181L	M-2032	SCR2-34-3446
	#1, 2	#2, 3	GT1-181V	M-2033	SCR2-34-1223
	2/0, 1/0	1/0, #1	GT1-182C	M-2034	SCR2-34-2010
	-	2/0	-	-	SCR2-34-0020*
	-	4/0	-	-	SCR2-34-0040*
Size (in.)	Solid	Stranded	TYPE NT(CR17)		TYPE CR17
½	#6, 8	#8	NT1-141G	-	-
	#3, 4	#4, 6	NT1-141L	-	-
	#1, 2	#2, 3	-	-	-
⅝	#6, 8	#8	NT1-161G	-	SCR17-58-6808
	#3, 4	#4, 6	NT1-161L	-	SCR17-58-3446
	#1, 2	#2, 3	NT1-161V	-	SCR17-58-1223
	2/0, 1/0	1/0, #1	-	-	SCR17-58-2010*
	-	2/0	-	-	SCR17-58-0020*
¾	#6, 8	#8	NT1-181G	-	SCR17-34-6808
	#3, 4	#4, 6	NT1-181L	-	SCR17-34-3446
	#1, 2	#2, 3	NT1-181V	-	SCR17-34-1223
	2/0, 1/0	1/0, #1	-	-	SCR17-34-2010*
	-	2/0	-	-	SCR17-34-0020*
	-	4/0	-	-	SCR17-34-0040*
Size (in.)	Solid	Stranded	TYPE NX(CR24)		TYPE CR24
½	#6, 8	#8	NX1-141G	-	-
	#3, 4	#4, 6	NX1-141L	-	-
	#1, 2	#2, 3	-	-	-
⅝	#6, 8	#8	NX1-161G	-	SCR24-58-6808
	#3, 4	#4, 6	NX1-161L	-	SCR24-58-3446

* Future development.

Exothermic welding system

Sure Shot cross reference

Ground rod	Conductor size (AWG or kcmil)		Cadweld cat. no.	Thermoweld cat. no.	Furseweld cat. no.
Size (in.)	Solid	Stranded	TYPE GR(CR1)	TYPE CR-1	TYPE CR1
3/4	#3, 4	#4, 6	NX1-181L	-	SCR24-34-3446
	#1, 2	#2, 3	NX1-181V	-	SCR24-34-1223
	2/0, 1/0	1/0, #1	-	-	SCR24-34-2010*
5/8	-	2/0	-	-	SCR24-34-0020*
	-	4/0	-	-	SCR24-34-0040*
Size (in.)	Solid	Stranded		TYPE CR-25	TYPE CR25
	#6, 8	#8	-	M-2006	SCR25-58-6808
	#3, 4	#4, 6	-	M-2007	SCR25-58-3446
	#1, 2	#2, 3	-	M-2008	SCR25-58-1223
3/4	2/0, 1/0	1/0, #1	-	M-2023	SCR25-58-12010
	#6, 8	#8	-	M-2068	SCR25-34-6808
	#3, 4	#4, 6	-	M-2069	SCR25-34-3446

* Future development.

Exothermic welding system

Additional tables

Conductor properties

Size (AWG or kcmil)	Area		Conductors							Direct-current resistance at 75 °C (167 °F)					
			Stranding			Overall				Copper					
	mm ²	Circular mils	Quantity	Diameter		Diameter		Area mm ²	Area in. ²	Uncoated		Coated		Aluminum	
				mm	in.	mm	in.			ohm/ km	ohm/ kFT	ohm/ km	ohm/ kFT	ohm/ km	ohm/ kFT
18	0.823	1,620	1	-	-	1.02	0.040	0.823	0.001	25.5	7.77	26.5	8.08	42.0	12.8
	0.823	1,620	7	0.39	0.015	1.16	0.046	1.06	0.002	26.1	7.95	27.7	8.45	42.8	13.1
16	1.31	2,580	1	-	-	1.29	0.051	1.31	0.002	16.0	4.89	16.7	5.08	26.4	8.05
	1.31	2,580	7	0.49	0.019	1.46	0.058	1.68	0.003	16.4	4.99	17.3	5.29	26.9	8.21
14	2.08	4,110	1	-	-	1.63	0.064	2.08	0.003	10.1	3.07	10.4	3.19	16.6	5.06
	2.08	4,110	7	0.62	0.024	1.85	0.073	2.68	0.004	10.3	3.14	10.7	3.26	16.9	5.17
12	3.31	6,530	1	-	-	2.05	0.081	3.31	0.005	6.34	1.93	6.57	2.01	10.45	3.18
	3.31	6,530	7	0.78	0.030	2.32	0.092	4.25	0.006	6.50	1.98	6.73	2.05	10.69	3.25
10	5.261	10,380	1	-	-	2.588	0.102	5.26	0.008	3.984	1.21	4.148	1.26	6.561	2.00
	5.261	10,380	7	0.98	0.038	2.95	0.116	6.76	0.011	4.070	1.24	4.226	1.29	6.679	2.04
8	8.367	16,510	1	-	-	3.264	0.128	8.37	0.013	2.506	0.764	2.579	0.786	4.125	1.26
	8.367	16,510	7	1.23	0.049	3.71	0.146	10.76	0.017	2.551	0.778	2.653	0.809	4.204	1.28
6	13.30	26,240	7	1.56	0.061	4.67	0.184	17.09	0.027	1.608	0.491	1.671	0.510	2.652	0.808
4	21.15	41,740	7	1.96	0.077	5.89	0.232	27.19	0.042	1.010	0.308	1.053	0.321	1.666	0.508
3	26.67	52,620	7	2.20	0.087	6.60	0.260	34.28	0.053	0.802	0.245	0.833	0.254	1.320	0.403
2	33.62	66,360	7	2.47	0.097	7.42	0.292	43.23	0.067	0.634	0.194	0.661	0.201	1.045	0.319
1	42.41	83,690	19	1.69	0.066	8.43	0.332	55.80	0.087	0.505	0.154	0.524	0.160	0.829	0.253
1/0	53.49	105,600	19	1.89	0.074	9.45	0.372	70.41	0.109	0.399	0.122	0.415	0.127	0.660	0.201
2/0	67.43	133,100	19	2.13	0.084	10.62	0.418	88.74	0.137	0.3170	0.0967	0.329	0.101	0.523	0.159
3/0	85.01	167,800	19	2.39	0.094	11.94	0.470	111.9	0.173	0.2512	0.0766	0.2610	0.0797	0.413	0.126
4/0	107.2	211,600	19	2.68	0.106	13.41	0.528	141.1	0.219	0.1996	0.0608	0.2050	0.0626	0.328	0.100
250	-	-	37	2.09	0.082	14.61	0.575	168	0.260	0.1687	0.0515	0.1753	0.0535	0.2778	0.0847
300	-	-	37	2.29	0.090	16.00	0.630	201	0.312	0.1409	0.0429	0.1463	0.0446	0.2318	0.0707
350	-	-	37	2.47	0.097	17.30	0.681	235	0.364	0.1205	0.0367	0.1252	0.0382	0.1984	0.0605
400	-	-	37	2.64	0.104	18.49	0.728	268	0.416	0.1053	0.0321	0.1084	0.0331	0.1737	0.0529
500	-	-	37	2.95	0.116	20.65	0.813	336	0.519	0.0845	0.0258	0.0869	0.0265	0.1391	0.0424
600	-	-	-	2.52	0.099	22.68	0.893	404	0.626	0.0704	0.0214	0.0732	0.0223	0.1159	0.0353
700	-	-	61	2.72	0.107	24.49	0.964	471	0.730	0.0603	0.0184	0.0622	0.0189	0.0994	0.0303
750	-	-	61	2.82	0.111	25.35	0.998	505	0.782	0.0563	0.0171	0.0579	0.0176	0.0927	0.0282
800	-	-	61	2.91	0.114	26.16	1.030	538	0.834	0.0528	0.0161	0.0544	0.0166	0.0868	0.0265
900	-	-	61	3.09	0.122	27.79	1.094	606	0.940	0.0470	0.0143	0.0481	0.0147	0.0770	0.0235
1000	-	-	61	3.25	0.128	29.26	1.152	673	1.042	0.0423	0.0129	0.0434	0.0132	0.0695	0.0212

FPN: The construction information is per NEMA WC8-1992 or ANSI/UL 1581-1998. The resistance is calculated per National Bureau of Standards Handbook 100, dated 1966, and Handbook 109, dated 1972. 70-625 TABLES.

Exothermic welding system

Additional tables

Metric conductors

Wire size		Circ mils	# of strands	Strand diameter	Diameter		Colour code	Die code
mm	AWG				mm	Inch		
10	8	19,73	1	3.57	3.57	0.140	Red	21
10	8	19,73	7	1.35	4.05	0.159	Red	21
16	6	31,558	1	4.50	4.50	0.177	Blue	24
16	6	31,558	7	1.70	5.10	0.200	Blue	24
25	2	49,325	7	2.14	6.42	0.253	Gray	29
25	2	49,325	19	1.35	6.75	0.266	Brown	33
35	1	69,055	19	1.53	7.65	0.300	Green	37
50	1/0	98,65	19	1.78	8.90	0.350	Pink	42
70	2/0	138,11	19	2.14	10.70	0.421	Black	45
95	3/0	187,5	19	2.52	12.60	0.496	Orange	50
95	3/0	187,5	37	1.78	12.46	0.490	Orange	50
120	250	236,76	37	2.03	14.21	0.560	Purple	54
150	300	295,95	37	2.25	15.75	0.620	White	66
185	-	365	61	2.52	17.64	0.695	Red	71
240	500	473,5	61	2.25	20.25	0.797	Brown	87
300	-	591,9	61	2.52	22.68	0.893	Green	94
400	-	789,2	61	2.85	25.65	1.000	Black	106
400	-	789,2	91	2.36	25.96	1.022	Black	106
500	-	986,5	61	3.20	28.80	1.134	-	125
500	-	986,5	91	2.65	29.15	1.148	-	-
630	-	1,243,000	127	2.52	32.76	1.290	-	-
800	-	1,578,400	127	2.85	37.05	1.459	-	-
1,000	-	1,973,000	127	3.20	41.60	1.638	-	-

Exothermic welding system

Additional tables

Table B.310.1 ampacities of two or three insulated conductors, rated 0 through 2000 V, within an overall covering (multiconductor cable), in raceway in free air based on ambient air temperature of 30 °C (86 °F)

Temperature rating of conductor

Size (AWG or kcmil)	60 °C (140 °F)	75 °C (167 °F)	90 °C (194 °F)	60 °C (140 °F)	75 °C (167 °F)	90 °C (194 °F)	Size (AWG or kcmil)
	Types TW, UF	Types RHW, THHW, THW, THWN, XHHW, ZW Copper	Types THHN, THHW, THW-2, THWN-2, RHH, RWH-2, USE-2, XHHN, XHHW-2, ZW-2	Type TW	Types RHW, THHW, THW, THWN, XHHW	Types THHN, THHW, THW-2, THWN-2, RHH, RWH-2, USE-2, XHHW, XHHW, XHHW-2, ZW-2	
14	16*	18*	21*	–	–	–	14
12	20*	24*	27*	16*	18*	21*	12
10	27*	33*	36*	21*	25*	28*	10
8	36	43	48	28	33	37	8
6	48	58	65	38	45	51	6
4	66	79	89	51	61	69	4
3	76	90	102	59	70	79	3
2	88	105	119	69	83	93	2
1	102	121	137	80	95	106	1
1/0	121	145	163	94	113	127	1/0
2/0	138	166	186	108	129	146	2/0
3/0	158	189	214	124	147	167	3/0
4/0	187	223	253	147	176	197	4/0
250	205	245	276	160	192	217	250
300	234	281	317	185	221	250	300
350	255	305	345	202	242	273	350
400	274	328	371	218	261	295	400
500	315	378	427	254	303	342	500
600	343	413	468	279	335	378	600
700	376	452	514	310	371	420	700
750	387	466	529	321	384	435	750
800	397	479	543	331	397	450	800
900	415	500	570	350	421	477	900
1,000	448	542	617	382	460	521	1,000

Correction factors

Ambient temp. (°C)	For ambient temperatures other than 30 °C (86 °F), multiply the ampacities shown above by the appropriate factor shown below.						Ambient temp. (°C)
21–25	1.08	1.05	1.04	1.08	1.05	1.04	70–77
26–30	1.00	1.00	1.00	1.00	1.00	1.00	79–86
31–35	0.91	0.94	0.96	0.91	0.94	0.96	88–95
36–40	0.82	0.88	0.91	0.82	0.88	0.91	97–104
41–45	0.71	0.82	0.87	0.71	0.82	0.87	106–113
46–50	0.58	0.75	0.82	0.58	0.75	0.82	115–122

*Unless otherwise specifically permitted elsewhere in this Code, the overcurrent protection for these conductor types shall not exceed 15 A for 14 AWG, 20 A for 12 AWG, and 30 A for 10 AWG copper; or 15 A for 12 AWG and 25 A for 10 AWG aluminum and copper-clad aluminum.
NATIONAL ELECTRICAL CODE, 2002 Edition.

Exothermic welding system

Additional tables

Table C1 maximum number of conductors or fixture wires in electrical metallic tubing (EMT) (based on table 1, chapter 9)

Conductors											
Type	Conductor size (AWG/kcmil)	Metric designator (trade size)									
		16 (½)	21 (¾)	27 (1)	35 (1¼)	41 (1½)	53 (2)	63 (2½)	78 (3)	91 (3½)	103 (4)
RHH,	14	4	7	11	20	27	46	80	120	157	201
RHW,	12	3	6	9	17	23	38	66	100	131	167
RHW-2	10	2	5	8	13	18	30	53	81	105	135
	8	1	2	4	7	9	16	28	42	55	70
	6	1	1	3	5	8	13	22	34	44	56
	4	1	1	2	4	6	10	17	26	34	44
	3	1	1	1	4	5	9	15	23	30	38
	2	1	1	1	3	4	7	13	20	26	33
	1	0	1	1	1	3	5	9	13	17	22
	1/0	0	1	1	1	2	4	7	11	15	19
	2/0	0	1	1	1	2	4	6	10	13	17
	3/0	0	0	1	1	1	3	5	8	11	14
	4/0	0	0	1	1	1	3	5	7	9	12
	250	0	0	0	1	1	1	3	5	7	9
	300	0	0	0	1	1	1	3	5	6	8
	350	0	0	0	1	1	1	3	4	6	7
	400	0	0	0	1	1	1	2	4	5	7
	500	0	0	0	0	1	1	2	3	4	6
	600	0	0	0	0	1	1	1	3	4	5
	700	0	0	0	0	0	1	1	2	3	4
	750	0	0	0	0	0	1	1	2	3	4
	800	0	0	0	0	0	1	1	2	3	4
	900	0	0	0	0	0	1	1	1	3	3
	1,000	0	0	0	0	0	1	1	1	2	3
TW,	14	8	15	25	43	58	96	168	254	332	424
THHW,	12	6	11	19	33	45	74	129	195	255	326
THW,	10	5	8	14	24	33	55	96	145	190	243
THW-2	8	2	5	8	13	18	30	53	81	105	135
RHH*,	14	6	10	6	28	39	64	112	169	221	282
RHW*,	12	4	8	13	23	31	51	90	136	177	227
RHW-2*	10	3	6	10	18	24	40	70	106	138	177
	8	1	4	6	10	14	24	42	63	83	106

* Types RHH, RHW, and RHW-2 without outer covering.

Conductors											
Type	Conductor size (AWG/kcmil)	Metric designator (trade size)									
		16 (½)	21 (¾)	27 (1)	35 (1¼)	41 (1½)	53 (2)	63 (2½)	78 (3)	91 (3½)	103 (4)
RHH,*	6	1	3	4	8	11	18	32	48	63	81
RHW,*	4	1	1	3	6	8	13	24	36	47	60
RHW-2*,	3	1	1	3	5	7	12	20	31	40	52
TW,	2	1	1	2	4	6	10	17	26	34	44
THHW,	1	1	1	1	3	4	7	12	18	24	31
THW,	1/0	0	1	1	2	3	6	10	16	20	26
THW-2	2/0	0	1	1	1	3	5	9	13	17	22
	3/0	0	1	1	1	2	4	7	11	15	19
	4/0	0	0	1	1	1	3	6	9	12	16
	250	0	0	1	1	1	3	5	7	10	13
	300	0	0	1	1	1	2	4	6	8	11
	350	0	0	0	1	1	1	4	6	7	10
	400	0	0	0	1	1	1	3	5	7	9
	500	0	0	0	1	1	1	3	4	6	7
	600	0	0	0	1	1	1	2	3	4	6
	700	0	0	0	0	1	1	1	3	4	5
	750	0	0	0	0	1	1	1	3	4	5
	800	0	0	0	0	1	1	1	3	3	5
	900	0	0	0	0	0	1	1	2	3	4
	1,000	0	0	0	0	0	1	1	2	3	4
THHN,	14	12	22	35	61	84	138	241	364	476	608
THWN,	12	9	16	26	45	61	101	176	266	347	443
THWN-2	10	5	10	16	28	38	63	111	167	219	279
	8	3	6	9	16	22	36	64	96	126	161
	6	2	4	7	12	16	26	46	69	91	116
	4	1	2	4	7	10	16	28	43	56	71
	3	1	1	3	6	8	13	24	36	47	60
	2	1	1	3	5	7	11	20	30	40	51
	1	1	1	1	4	5	8	15	22	29	37
	1/0	1	1	1	3	4	7	12	19	25	32
	2/0	0	1	1	2	3	6	10	16	20	26
	3/0	0	1	1	1	3	5	8	13	17	22
	4/0	0	1	1	1	2	4	7	11	14	18
	250	0	0	1	1	1	3	6	9	11	15
	300	0	0	1	1	1	3	5	7	10	13
	350	0	0	1	1	1	2	4	6	9	11
	400	0	0	0	1	1	1	4	6	8	10
	500	0	0	0	1	1	1	3	5	6	8
	600	0	0	0	1	1	1	2	4	5	7
	700	0	0	0	1	1	1	2	3	4	6
	750	0	0	0	0	1	1	1	3	4	5
	800	0	0	0	0	1	1	1	3	4	5
	900	0	0	0	0	1	1	1	3	3	4
	1,000	0	0	0	0	1	1	1	2	3	4

NATIONAL ELECTRICAL CODE, 2002 Edition
* Types RHH, RHW, and RHW-2 without outer covering.

Exothermic welding system

Additional tables

Table C8 maximum number of conductors or fixture wires in rigid metal conduit (RMC) (based on table 1, chapter 9)

Conductors													
Type	Conductor Size (AWG/ kcmil)	Metric designator (trade size)											
		16 (½)	21 (¾)	27 (1)	35 (1¼)	41 (1½)	53 (2)	63 (2½)	78 (3)	91 (3½)	103 (4)	129 (5)	155 (6)
RHH, RHW, RHW-2	14	4	7	12	21	28	46	66	102	136	176	276	398
	12	3	6	10	17	23	38	55	85	113	146	229	330
	10	3	5	8	14	19	31	44	68	91	118	185	267
	8	1	2	4	7	10	16	23	36	48	61	97	139
	6	1	1	3	6	8	13	18	29	38	49	77	112
	4	1	1	2	4	6	10	14	22	30	38	60	87
	3	1	1	2	4	5	9	12	19	26	34	53	76
	2	1	1	1	3	4	7	11	17	23	29	46	66
	1	0	1	1	1	3	5	7	11	15	19	30	44
	1/0	0	1	1	1	2	4	6	10	13	17	26	38
	2/0	0	1	1	1	2	4	5	8	11	14	23	33
	3/0	0	0	1	1	1	3	4	7	10	12	20	28
	4/0	0	0	1	1	1	3	4	6	8	11	17	24
	250	0	0	0	1	1	1	3	4	6	8	13	18
	300	0	0	0	1	1	1	2	4	5	7	11	16
	350	0	0	0	1	1	1	2	4	5	6	10	15
	400	0	0	0	1	1	1	1	3	4	6	9	13
	500	0	0	0	1	1	1	1	3	4	5	8	11
	600	0	0	0	0	1	1	1	2	3	4	6	9
	700	0	0	0	0	1	1	1	1	3	4	6	8
750	0	0	0	0	0	1	1	1	3	3	5	8	
800	0	0	0	0	0	1	1	1	2	3	5	7	
900	0	0	0	0	0	1	1	1	2	3	5	7	
1,000	0	0	0	0	0	1	1	1	1	3	4	6	
TW,	14	9	15	25	44	59	98	140	216	288	370	581	839
THHW,	12	7	12	19	33	45	75	107	165	221	284	446	644
THW,													
THW-2	10	5	9	14	25	34	56	80	123	164	212	332	480
	8	3	5	8	14	19	31	44	68	91	118	185	267
RHH,*	14	6	10	17	29	39	65	93	143	191	246	387	558
RHW,*													
RHW-2*													
RHH,*	12	5	8	13	23	32	52	75	115	154	198	311	448
RHW,*													
RHW-2*	10	3	6	10	18	25	41	58	90	120	154	242	350
RHH,*	8	1	4	6	11	15	24	35	54	72	92	145	209
RHW,*													
RHW-2*													

Exothermic welding system

Additional tables

Table C8 maximum number of conductors or fixture wires in rigid metal conduit (RMC) (based on table 1, chapter 9)

Conductors													
Type	Conductor Size (AWG/kcmil)	Metric designator (trade size)											
		16 (½)	21 (¾)	27 (1)	35 (1¼)	41 (1½)	53 (2)	63 (2½)	78 (3)	91 (3¾)	103 (4)	129 (5)	155 (6)
RHH,*	6	1	3	5	8	11	18	27	41	55	71	111	160
RHW,*	4	1	1	3	6	8	14	20	31	41	53	83	120
RHW-2*,	3	1	1	3	5	7	12	17	26	35	45	71	103
TW,	2	1	1	2	4	6	10	14	22	30	38	60	87
THHW,	1	1	1	1	3	4	7	10	15	21	27	42	61
THW,	1/0	0	1	1	2	3	6	8	13	18	23	36	52
THW-2	2/0	0	1	1	2	3	5	7	11	15	19	31	44
	3/0	0	1	1	1	2	4	6	9	13	16	26	37
	4/0	0	0	1	1	1	3	5	8	10	14	21	31
	250	0	0	1	1	1	3	4	6	8	11	17	25
	300	0	0	1	1	1	2	3	5	7	9	15	22
	350	0	0	0	1	1	1	3	5	6	8	13	19
	400	0	0	0	1	1	1	3	4	6	7	12	17
	500	0	0	0	1	1	1	2	3	5	6	10	14
	600	0	0	0	1	1	1	1	3	4	5	8	12
	700	0	0	0	0	1	1	1	2	3	4	7	10
	750	0	0	0	0	1	1	1	2	3	4	7	10
	800	0	0	0	0	1	1	1	2	3	4	6	9
	900	0	0	0	0	1	1	1	1	3	4	6	8
	1,000	0	0	0	0	0	1	1	1	2	3	5	8
THHN,	14	13	22	36	63	85	140	200	309	412	531	833	1,202
THWN,	12	9	16	26	46	62	102	146	225	301	387	608	877
THWN-2	10	6	10	17	29	39	64	92	142	189	244	383	552
	8	3	6	9	16	22	37	53	82	109	140	221	318
	6	2	4	7	12	16	27	38	59	79	101	159	230
	4	1	2	4	7	10	16	23	36	48	62	98	141
	3	1	1	3	6	8	14	20	31	41	53	83	120
	2	1	1	3	5	7	11	17	26	34	44	70	100
	1	1	1	1	4	5	8	12	19	25	33	51	74
	1/0	1	1	1	3	4	7	10	16	21	27	43	63
	2/0	0	1	1	2	3	6	8	13	18	23	36	52
	3/0	0	1	1	1	3	5	7	11	15	19	30	43
	4/0	0	1	1	1	2	4	6	9	12	16	25	36
	250	0	0	1	1	1	3	5	7	10	13	20	29
	300	0	0	1	1	1	3	4	6	8	11	17	25
	350	0	0	1	1	1	2	3	5	7	10	15	22
	400	0	0	1	1	1	2	3	5	7	8	13	20
	500	0	0	0	1	1	1	2	4	5	7	11	16
	600	0	0	0	1	1	1	1	3	4	6	9	13
	700	0	0	0	1	1	1	1	3	4	5	8	11
	750	0	0	0	0	1	1	1	3	4	5	7	11
	800	0	0	0	0	1	1	1	2	3	4	7	10
	900	0	0	0	0	1	1	1	2	3	4	6	9
	1,000	0	0	0	0	1	1	1	1	3	4	6	8

Note: This table is for concentric stranded conductors only.
 For compact stranded conductors, Table C8(A) should be used.
 *Types RHH, RHW, and RHW-2 without outer covering.

Competitive cross reference

Figure 6 — Compression ground tap connectors

EZGround	Burndy	IlSCO
54855	YGHP29C2	GGC-2
54860	YGHP29C26	GGC-3
54865	YGHP29C29	GGC-4
54875	YGHP2C2	GGC-1
54885	YGHP34C2	GGC-5
54890	YGHP34C26	GGC-6
54895	YGHP34C29	GGC-7
54900	YGHP34C34	GGC-8

Figure 6 to figure 6 — Compression ground grid connectors

EZGround	Burndy	IlSCO
54855L	YGL2C2	-
54855LR12	YGLR29C12	-
54865L	YGL29C2	GGA-2
54865LR58	YGLR29C58	-
54875L	YGL29C29	GGA-3
54875LR34	YGLR29C34	-
54885L	YGL34C2	GGA-4
54885LR12	YGLR34C12	-
54895L	YGL34C29	GGA-5
54895LR58	YGLR34C58	-
54900L	YGL34C34	GGA-6
54900LR34	YGLR34C34	-
54910LR100	YGLR29C100	-
54920LR100	YGLR34C100	-

C-crimp series BC

EZGround	Burndy	IlSCO
BC202	YC26C2	-
BC2020-BB	YC26C26	-
BC22	YC2C2	ULT-7-Z
BC24	YC2C4	ULT-6-Z
BC402	YC28C2	-
BC4020	YC28C26	-
BC4040	YC28C28	ULT-12-Z
BC44	YC4C4	ULT-5-Z
BC46-BB	YC4C6	ULT-4-Z
BC48	YC4C8	-

C-taps

EZ Ground	Burndy	IlSCO
CTG250	GCM28CG3	-

Type SP — Service post connectors

Blackburn	Penn Union	Burndy	IlSCO/Utilco	Kupler
SP0DL	SCS-0A1	K2C15B1	-	-
SP1DL	SCS-1A1	K2C17B1	-	-
SP2DL	SCS-2A1	K2C20B1	-	-
SP3DL	SCS-3A1	K2C22B1	-	-
SP4DL	SCS-4A1	K2C23B1	-	-
SP5DL	SCS-5A1	K2C25B1	-	-
SP6DL	SCS-6A1	K2C26B1	-	-
SP8DL	SCS-8A1	K2C28B1	-	-
SP9DL	SCS-9A1	K2C31B1	-	-
SP10DL	SCS-10A1	K2C34B1	-	-
SP0SL	SSS-0A1	KC15B1	-	-
SP1SL	SSS-1A1	KC17B1	-	-
SP2SL	SSS-2A1	KC20B1	-	-
SP3SL	SSS-3A1	KC22B1	-	-
SP4SL	SSS-4A1	KC23B1	-	-
SP5SL	SSS-5A1	KC25B1	-	-
SP6SL	SSS-6A1	KC26B1	-	-
SP8SL	SSS-8A1	KC28B1	-	-
SP9SL	SSS-9A1	KC31B1	-	-
SP10SL	SSS-10A1	KC34B1	-	-

Flexible braids

Blackburn	Penn Union	Burndy	IlSCO/ Utilco	Penn-Union	Anderson	Dossert	Gedney
FB2D12	-	B2D12N	-	FXB2A-12-Q	-	-	-
FB2E12	-	B2E12N	-	FXB2C-12N-Q	-	-	-
FB2F12	-	B2F12N	-	FXB2D-12N-Q	-	-	-
FB3D12	-	B3D12N	-	FXB3A-12-Q	-	-	-
FB3E12	-	B3E12N	-	FXB3C-12N-Q	-	-	-
FB3F12	-	B3F12N	-	-	-	-	-
FB3XD12	-	B4D12N	-	-	-	-	-
FB4E12	-	B4E12N	-	FXB4C-12N-Q	-	-	-
FB4F12	-	B4F12N	-	FXB4D-12N-Q	-	-	-
FBD12	-	BD12N	-	FXBA-12-Q	-	-	-
FBD18	-	-	-	FXBA-18-Q	-	-	-
FBD24	-	-	-	FXBA-24-Q	-	-	-
FBE12	-	BE12N	-	FXBB-12N-Q	-	-	-
FBF12	-	BF12N	-	FXBD-12N-Q	-	-	-
FBG12	-	-	-	FXBE-12N-Q	-	-	-
FBG18	-	-	-	FXBE-18S-Q	-	-	-
FBG24	-	-	-	FXBE-24S-Q	-	-	-

Competitive cross reference

Ground plates

EZGround	Burndy	-	-	-	-	-	-
GP2250-2	YGF29-2N						
GP2250-4	YGF29-4N						
GP250500-2	YGF34-2N						
GP250500-4	YGF34-4N						

Figure 8 — Compression tap connectors for copper ground rods

EZGround	Burndy	-	-	-	-	-	-
GR1-202	YGHR26C100						
GR12-202	YGHR26C12						
GR12-40250	YGHR29C12						
GR1-300500	YGHR34C100						
GR1-40250	YGHR29C100						
GR34-202	YGHR26C34						
GR34-300500	YGHR34C34						
GR34-40250	YGHR29C34						
GR58-202	YGHR26C58						
GR58-300500	YGHR34C58						
GR58-40250	YGHR29C58						

Type TBGS — Structural grounding studs

EZGround	Burndy	-	-	-	-	-	-
TBGS14	GSTUD14HY						
TBGS34	GSTUD34HY						
TBGS38	GSTUD38HY						
TBGS58	GSTUD916HY						

Type JAB — Ground rod clamps

Blackburn	Penn Union	Burndy	IlSCO	Eritech	Anderson	Joslyn	Dossert
JAB12	CAB-1	GRC12	CGRC48	HDC12	-	J8391AB	GNA50
JAB58	CAB-2	GRC58	CGRC58	-	-	J8392AB	GNA62
JAB34	CAB-3	-	-	HDC34	-	J8393AB	GNA75
JAB34C	-	GRC3426	CGRC68	-	-	-	-
JAB1	-	-	-	-	-	-	-
JAB12H	CAB-1	-	-	HDC12	GC-103-01	J8491AB	GN-50
JAB58H	CAB-2	-	-	HDC58R	GC-103-02	A8393AB	GN-62
JAB34H	CAB-3	-	-	HDC34	GC-103-03	J8493AB	GN-75
JAB1H	-	-	-	-	-	-	-

Type G — Budget line ground rod clamps

Blackburn	Penn Union	Burndy	IlSCO	Eritech	Anderson	Joslyn	Dossert
G3	CAB-1	GRC12	-	CP38	-	-	-
G4	CEB-1	GRC-12	GRC-48	CP12	GC-4	-	GNL50
G5	CEB-2	GRC-58	GRC-58	CP58	GC-5	-	GNL62
G6	CEB-3	GRC34	GRC-68	CP34	GC-6	-	GNL75

Blackburn and EZGround are registered trademarks for ABB.
All other trademarks are the property of their respective owners.

Competitive cross reference

Type GUV — U-bolt clamps

Blackburn	Penn Union	Burndy	IlSCO/Utilco	Homac®	Anderson	Dossert	Gedney
GUV4021	–	GAR2226	–	–	–	–	–
GUV4025	–	GAR2229	–	–	–	–	–
GUV584	–	GAR644C	–	–	–	–	–
GUV5821	–	GAR6426	–	–	–	–	–
GUV5825	–	GAR6429	–	–	–	–	–
GUV784	GPL-8	GAR144C	–	–	–	–	–
GUV7821	GPL-9	GAR1426	–	–	–	–	–
GUV7825	GPL-10	GAR1429	–	–	–	–	–
GUV1184	GPL-14	GAR154C	–	–	–	–	–
GUV11821	GPL-15	GAR1526	–	–	–	–	–
GUV1384	GPL-20	GAR164C	–	–	–	–	–
GUV13821	–	GAR1626	–	–	–	–	–
GUV13825	GPL-22	GAR1629	–	–	–	–	–
GUV1584	GPL-26	GAR174C	–	–	–	–	–
GUV15821	GPL-27	GAR1726	–	–	–	–	–
GUV15825	GPL-28	GAR1729	–	–	–	–	–
GUV204	GPL-32	GAR184C	–	–	–	–	–
GUV2021	GPL-33	GAR1826	–	–	–	–	–
GUV2025	GPL-34	GAR1829	–	–	–	–	–
GUV21221	GPL-39	GAR1926	–	–	–	–	–
GUV21225	GPL-40	GAR1929	–	–	–	–	–
GUV3021	GPL-45	GAR2026	–	–	–	–	–
GUV3025	GPL-46	GAR2029	–	–	–	–	–
GUV31221	GPL-51	GAR2126	–	–	–	–	–

Type GTC — Tower ground clamps

Blackburn	Penn Union	Burndy	IlSCO/Utilco	Homac	Anderson	Dossert	Gedney
GTC13	GMS-2	GBM26	–	–	GC140-01	GFM-13	–
GTC14	GMS-3	GBM29	–	–	GC-140-02	GFM-25	–
GTC23	GM-2	GB26	–	–	GC141-01	GF13	–
GTC24	GM-3	GB29	–	–	–	GF25	–

Type TTC — Transformer tank ground connectors

Blackburn	Penn Union	Burndy	IlSCO/Utilco	Homac	Anderson	Dossert	Eritech
TTC2	HGSE-020	EQC632C	–	–	GTCL-34A	–	TGC210
TTC3	HGSE-C1	–	–	–	GTCL-23A	TGC8-50	–
TTC4	–	–	–	–	–	–	–
TTC2P	–	–	–	–	–	–	–
TTC3P	GSE-C1TN	–	–	–	GTC23A-TP	TGC8-50SN	–
TTC4P	–	–	–	–	–	–	–

Type GP — Copper pole bottom ground plates

Blackburn	Penn Union	Burndy	IlSCO/Utilco	Homac	Anderson	Dossert	Eritech
GP100	–	–	–	5575	–	–	EGP100

Blackburn and Homac are registered trademarks for ABB.
All other trademarks are the property of their respective owners.

Replacement ABB catalogue number

Old ABB cat. no.	New cat. no.
BP4UCR	TBM6UCR-LI
BPI42300CR	TBM62CR-LI
BPLT14BSR	TBM14CR-LI
BPLT15BSCR	TBM15CR-LI
BPLT58B SCT	TBM58PCTS-LI
BPLT62BSCR	TBM62PCR-LI
BPLT6500BSCR	TBM6PCR-LI
BPLT6BSCR	TBM6PCR-LI
HMC-5630	HMC5630-LI
HMC5750	HMC5750-LI

Replacement ABB catalogue number

Old ABB cat. no.	New cat. no.
TBM14BSCR	TBM14CR-LI
TBM15BSCR	TBM15CR-LI
TBM4BB	TBM45BB and TBM45S
TBM54B SCT	TBM54CT-LI
TBM54B SCTS	TBM54CTS-LI
TBM58B SCT	TBM58PCTS-LI
TBM61520BSCR	BPLT62BSCR
TBM62BSCR	TBM62PCR-LI
TBM0DBSCR	TBM6UNICR-LI