

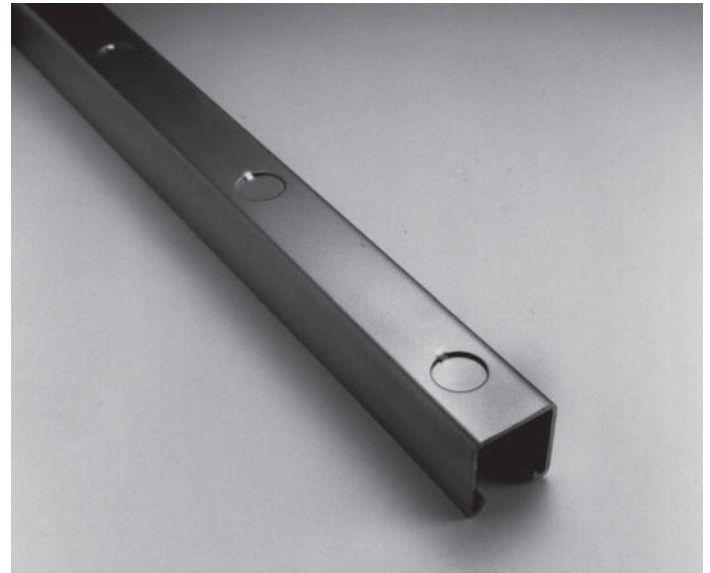

**SECTION 0**  
**SURFACE RACEWAY AND**  
**LIGHTING SYSTEMS**

**Thomas & Betts**

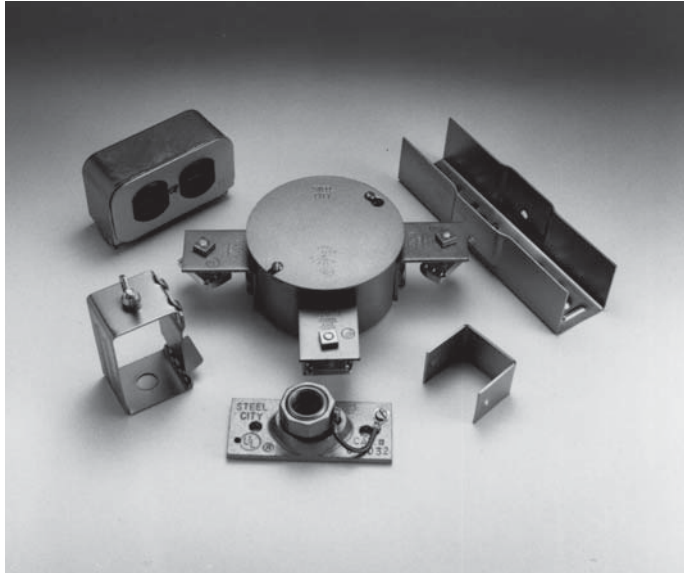

**Material**

Superstrut® electrical raceway, fixture hanging channel, closure strip and accessories are manufactured from hot rolled strip steel. Standard finish for the accessories is GoldGalv®.

**Design Data**

Deflections at various hanger rod spacings for raceway channels based on 40 to 45 lb per fixture.

Channel	Deflection		
	at 10 ft	at 12 ft	at 14 ft
A1200	1/4"	1/2"	3/4"
C1200	3/8"	3/4"	*
A1400	3/8"	3/4"	*

Channel	Deflection		
	at 6 ft	at 7 ft	at 9 ft
B1200	3/8"	9/16"	5/8"
B1400	1"	1/2"	*

\*Not recommended for this spacing.

**Electrical Raceway**

Superstrut channel together with snap-in closure strip is listed by Underwriters Laboratories as a surface metal raceway. Other accessories listed by Underwriters Laboratories are identified on the drawings.

**MAXIMUM NUMBER OF WIRES**

Wire Size AWG	Raceway							
	With or without KO							
	A1200		B1200		C1200		E1200	
	A	B	A	B	A	B	A	B
14	6	10	4	6	5	10	6	10
12	6	10	3	6	4	10	6	10
10	5	8			4	6	5	8
8	4	6			3	4	4	6
6	2	3			2	2	2	3

COLUMN A: Suitable for number of wires indicated when used as a raceway. Also suitable for number of wires indicated when installed to support and supply electrical fixtures when raceway wiring is suitable for not less than 75°C.

By providing clearance between fixture and raceway of not less than 1/2", where suitable for 60°C may be used.

COLUMN B: Suitable for number of wires indicated when used as a raceway. Also suitable for number of wires indicated when installed to support electrical fixtures when clearance of not less than 1/8" is provided between raceway and fixture and when wiring is suitable for 75°C.

**Applicable Channels**

A1200	B1200
A1200-KO	B1400
A1400	C1200
A1400-KO	E1200
	H1200



**SECTION 6**

**Surface Raceway and Lighting Systems**

**Fixture Fittings**

**802**  
Raceway Joiner With Reinforcing Plate

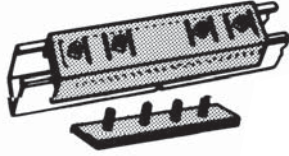

Furnished complete with nuts.

Cat. No.	For Channel	Wt./C lb
<b>A802EG</b>	A Series	158
<b>B802EG</b>	B Series	112
<b>E802EG</b>	E Series	170
<b>H802</b>	H Series	182

**822**  
Raceway Joiner & Seal

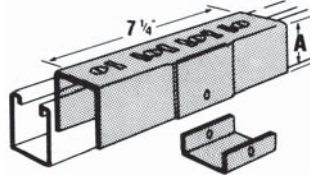

Furnished complete with 1/4" x 5/8" machine screws and AB100-1/4 nuts.

Cat. No.	A	For Channel	Wt./C lb
<b>A822</b>	1-11/16	A Series	75
<b>B822</b>	7/8	B Series	56

**A213**  
Inside Joiner

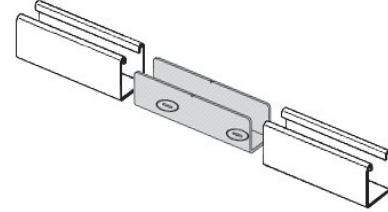

For A1200 series channel  
Only available in GoldGalv® finish

**805**  
End Cap With Knockout

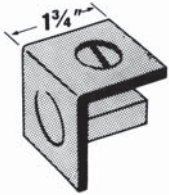

KO for 1/2" conduit.  
Furnished complete with 1/4" x 5/8" flat head machine screw and AB100-1/4 nut.

Cat. No.	For Channel	Wt./C lb
<b>A805EG</b>	A Series	21
<b>H805EG</b>	H Series	31

**809**  
Tapped End Cap

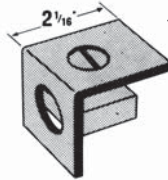

12 ga. steel. For 3/4" or 1" conduit. Furnished complete with 1/4" x 5/8" flat head machine screw and AB100-1/4 nut.

Cat. No.	For Channel	Wt./C lb
<b>A809-3/4EG</b>	A Series	2
<b>E809-3/4EG</b>	E Series	26

**A853**  
Channel Hanger



Use hanger rod 3/8" or 1/2". Use with A, AR, B, BR or C series single channel.

Wt./C 25 lb

**A853L**  
Channel Hanger - Long

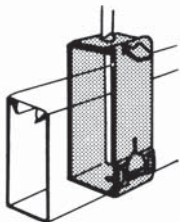

Long type for all series channel.

Wt./C 48 lb

**A854**  
Channel Hanger

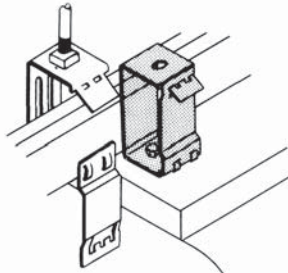

Illustration showing A854 with nut and bolt furnished to attach to fluorescent fixture. Use with A, B, C or D series channel.

Wt./C 34 lb

**A854L**  
Channel Hanger - Long

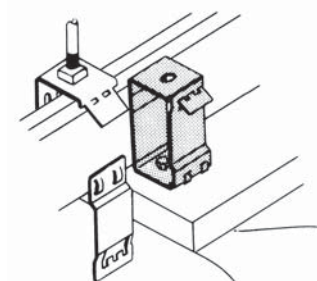

Illustration showing A854L with nut and bolt furnished to attach to fluorescent fixture. Use with E and H series channel as well as A, B, C or D.

Wt./C 51 lb

**Surface Raceway and Lighting Systems**

**SECTION 6**

**Fixture Fittings**

**AB844PGC**  
Steel Closure Strip

**AB844PC**  
Plastic Closure Strip Colour: Gold

**AB844PCGY**  
Plastic Closure Strip Colour: Grey

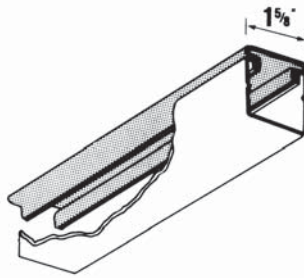

- When used as a raceway is channel is normally installed with the slot up. After wiring has been completed the closure strip is installed.
- For all channels.
- Standard length: 10 ft

**AB803**  
Cast Conduit Connector

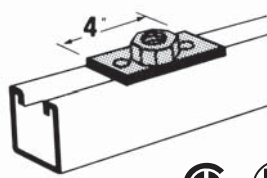

To connect 1/2" or 3/4" conduit to raceway channel. Furnished complete with stud nuts and hex nuts. Part has removable bushing to increase size from 1/2" to 3/4".

Wt./C 60 lb

**AB815**  
Swing Connector

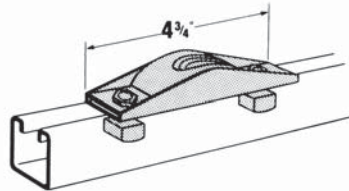

Nuts and bolts to clamp to channel is included. For 1/2" or 3/4" conduit.

Wt./C 95 lb

**AB885**  
15° Swivel

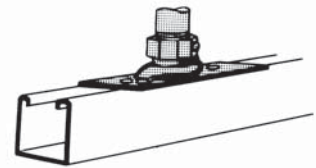

Nuts and bolts to clamp to channel included. For 1/2" or 3/4" conduit.

Wt./C 25 lb

**AB867**  
Spacer

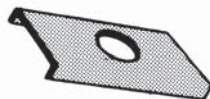

For use with AB866 wiring stud nuts.

Wt./C 24 lb

**AB866**  
Wiring Stud Nut

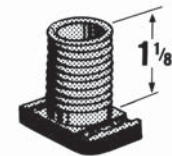

1/2" Pipe thread

Wt./C 21 lb

**811**  
Stud Nut

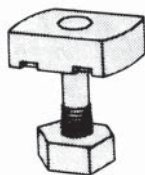

Cat. No.	For Channel	Wt./C lb
811-1STR	1/4 x 1	8
811-2STR	1/4 x 1-1/4	9

**812**  
Stud Nut

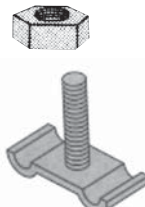

For attaching fixture to slot down channel or to slot up knockouts. Specify length. Hex nut included.

Cat. No.	For Channel	Wt./C lb
812-1EG	1/4 x 1	6

**AB868**  
Fiber Retainer for Cables Until Closure Strip is Installed

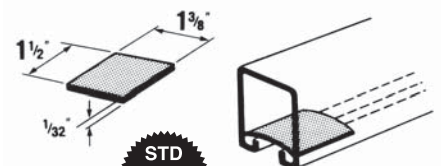











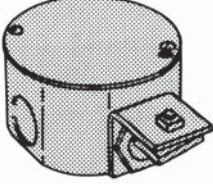

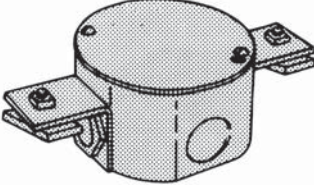

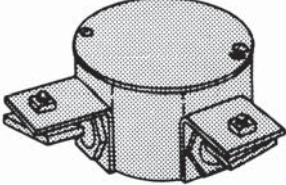

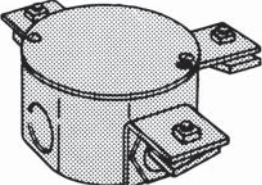

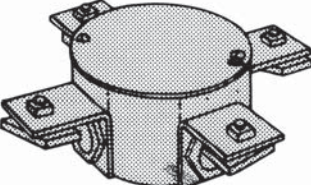

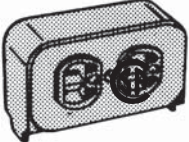
Wt./C 3 lb

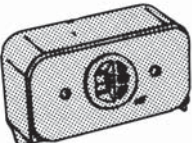
**SECTION 6**

**Surface Raceway and Lighting Systems**

**Kindorf® Channel Boxes and Receptacles**

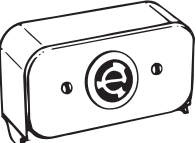
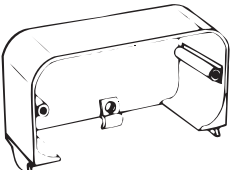
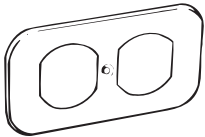
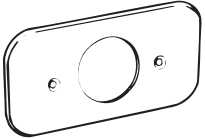
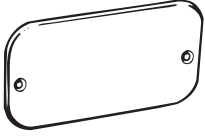
<p><b>G2000</b>  </p>  <p><i>Finish - GoldGalv®</i> Wt./C 110 lb</p>	<p><b>G2001</b>  </p>  <p><i>Finish - GoldGalv®</i> Wt./C 120 lb</p>	<p><b>G2002</b>  </p>  <p><i>Finish - GoldGalv®</i> Wt./C 120 lb</p>	
<p><b>G2003</b>  </p>  <p><i>Finish - GoldGalv®</i> Wt./C 130 lb</p>	<p><b>G2004</b>  </p>  <p><i>Finish - GoldGalv®</i> Wt./C 140 lb</p>	<p><b>G1038 Duplex Outlet</b>  </p>  <p>Complete unit including housing, standard DUPLEX 3-wire, 15 Amp., 125 volt, ground receptacle and cover plate.</p> <p><i>Finish - GoldGalv®</i> Wt./C 55 lb</p>	
<p><b>G1038A Single Outlet</b>  </p>  <p>Complete unit including housing, standard SINGLE 3-wire, 15 Amp., 125 volt, ground receptacle and cover plate.</p> <p><i>Finish - GoldGalv®</i> Wt./C 50 lb</p>	<p><b>G1038D Raceway Outlet</b>  </p>  <p>Complete unit including housing, duplex, 3-wire, 15 amp. 277 volt-twistlock receptacle and cover plate. U.L.</p> <p><i>Finish - GoldGalv®</i> Wt./C 60 lb</p>	<p><b>G1038E Raceway Outlet</b>  </p>  <p>Complete unit including housing, single, 3-wire, 15 amp. 277 volt-twistlock receptacle and cover plate.</p> <p><i>Finish - GoldGalv®</i> Wt./C 50 lb</p>	
<p><b>G1038B Housing Only</b></p>  <p><i>Finish - GoldGalv®</i> Wt./C 25 lb</p>	<p><b>G1038C Duplex Cover Plate</b></p>  <p><i>Finish - GoldGalv®</i> Wt./C 12 lb</p>	<p><b>G1038CA Single Cover Plate</b></p>  <p>Size of opening: 1.391 diameter</p> <p><i>Finish - GoldGalv®</i> Wt./C 14 lb</p>	<p><b>G1038CX Blank Cover Plate</b></p>  <p><i>Finish - GoldGalv®</i> Wt./C 15 lb</p>

**Kindorf® Fixture Accessories**

**G1017**

**Mercury Vapor Hanger**

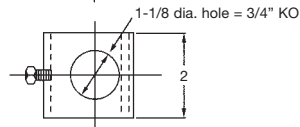
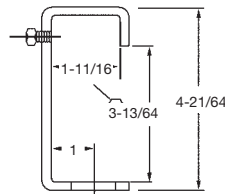
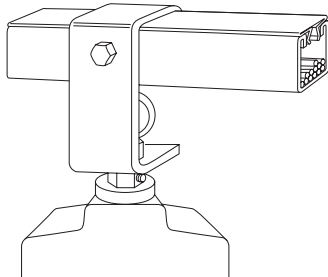

Used with Channel	Depth in.	Wt./C lb
A-1200	4-1/4"	76

**Finish - GoldGalv®**

To support high or low bay mercury vapor or heavy incandescent fixtures from raceway channels. Permits plug-in connections with G-1038 raceway outlets.

**G972HB1/2**

**Steel Fixture Hanger Adapter**

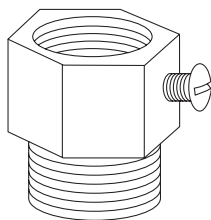

**Finish - GoldGalv®**

The hanger adapter securely mounts the fixture hanger or box to the channel through the 1/2" KO in the base. No special tools are needed for installation of fittings and fixtures. Superstrut® channels, with 1/2" KO's every 6", hangs and feeds the fixtures thereby simplifying installation.

Wt./C 17 lb

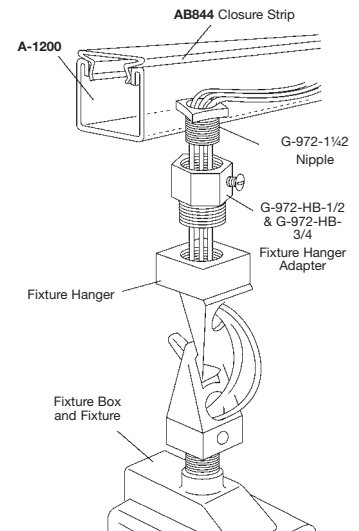

**Electrical Applications**

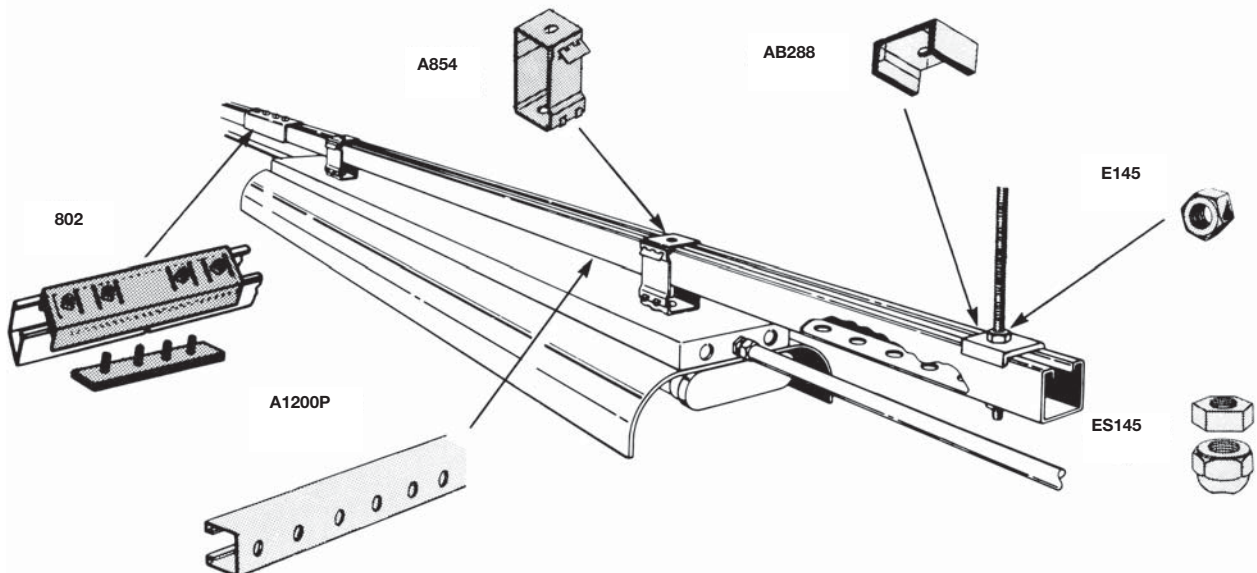

**Electrical Applications**

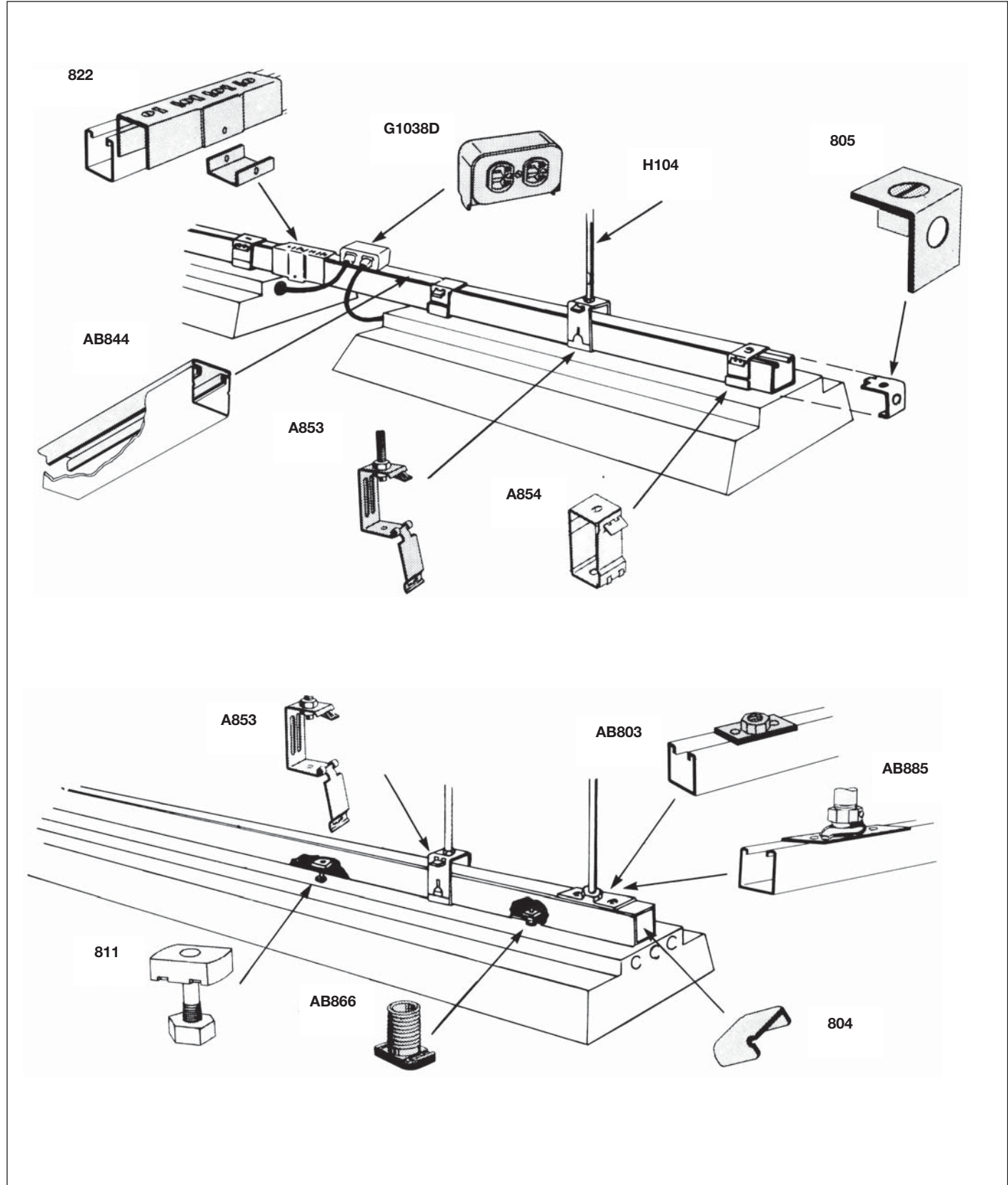

**Electrical Applications**

