



SECTION 0
ENGINEERING DATA AND
SPECIFICATIONS

Thomas & Betts

**Design Data –
Metal Framing Channel**

**TABLE 1
Properties for Design**

Elements of Sections

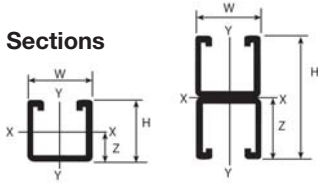

Single Channels Double Channels

**Nominal Thickness
(inches)**

- 12 ga = .105
- 14 ga = .075
- 16 ga = .060

Legend

- I - Moment of inertia
- S - Section Modulus
- r - Radius of Gyration
- Z - Nominal Axis
- A - Area

SECTION MEMBER	WT. lb/ft	H in.	W in.	A in. ²	X-X AXIS				Y-Y AXIS		
					I in. ⁴	S in. ³	r in.	Z in.	I in. ⁴	S in. ³	r in.
SINGLE CHANNEL											
A1200	1.90	1.625	1.625	.557	.192	.212	.587	.719	.237	.292	.652
B1200	1.28	.813	1.625	.381	.031	.063	.283	.331	.137	.168	.600
C1200	1.70	1.375	1.625	.500	.121	.155	.492	.595	.205	.252	.640
D1200	1.44	1.000	1.625	.424	.053	.092	.356	.403	.159	.196	.616
E1200	2.47	2.438	1.625	.726	.529	.399	.853	1.112	.335	.413	.679
H1200	3.05	3.250	1.625	.897	1.100	.635	1.107	1.507	.436	.536	.697
A1400	1.40	1.625	1.625	.401	.134	.146	.577	.707	.184	.226	.677
B1400	.97	.813	1.625	.280	.024	.051	.295	.338	.103	.127	.607
DOUBLE CHANNEL											
A1202	3.80	3.250	1.625	1.114	.948	.583	.992	1.625	.474	.584	.652
B1202	2.56	1.626	1.625	.762	.147	.181	.439	.813	.274	.337	.600
C1202	3.40	2.750	1.625	1.000	.595	.433	.772	1.375	.409	.504	.640
D1202	2.88	2.000	1.625	.847	.257	.257	.552	1.090	.319	.393	.616
E1202	4.94	4.876	1.625	1.450	2.854	1.171	1.402	2.438	.672	.827	.680
H1202	6.10	6.500	1.625	1.794	6.273	1.930	1.870	3.250	.871	1.072	.697
A1402	2.80	3.250	1.625	.801	.668	.411	.913	1.625	.367	.452	.677
B1402	1.94	1.626	1.625	.560	.112	.138	.447	.813	.206	.254	.607

TABLE 2

Maximum Pullout and Slip Loads for Steel Channel and Channel Nuts

Channel Nut Size / Thread	Channel All Series	Pull-Out Strength		Slip Resistance		Torque	
		lb	kN	lb	kN	ft lb	N-m
1/4 - 20	A1200	600	2.7	300	1.3	6	8
5/16 - 18	B1200	800	3.6	500	2.2	11	15
3/8 - 16	C1200	1000	4.4	800	3.6	19	25
1/2 - 14	D1200	2000	8.9	1500	6.7	50	70
5/8 - 11	E1200	2500	11.1	1500	6.7	100	135
3/4 - 10	H1200	2500	11.1	1700	7.6	125	170
1/4 - 20	A1400	600	2.7	300	1.3	6	8
5/16 - 18	B1400	800	3.6	400	1.8	11	15
3/8 - 16		1000	4.4	750	3.3	19	25
1/2 - 14		1400	6.2	1000	4.4	50	70
1/4 - 20	AR1600	600	2.7	300	1.3	6	8
5/16 - 18	BR1600	800	3.6	400	1.8	11	15
3/8 - 16		1000	4.4	750	3.3	19	25
1/2 - 14		1000	4.4	1000	4.4	50	70

For aluminum channel the pull out load is calculated by multiplying the appropriate data by 50%. For slip resistance multiply by 75%.

Maximum Pullout and Slip Loads for Fiber Glass Channel and Channel Nuts

Channel Nut Size / Thread	Channel All Series	Pull-Out Strength		Slip Resistance		Torque	
		lb	kN	lb	kN	ft lb	N-m
1/4 - 20	-	-	-	-	-	-	-
5/16 - 18	-	-	-	-	-	-	-
3/8 - 16	A1200	300	1.3	150	0.6	200	22.6
1/2 - 13	D1200	300	1.3	150	0.6	200	22.6

Design Data – Metal Framing Channel**TABLE 3**

Design loads for channel used as beam or column

BEAM LOADS

Table 3 contains simple beam, uniformly-distributed loads calculated at 25,000 psi material stress. Beam loads are based on channel being loaded across the x-x axis. Loads are also listed at reduced deflections for long spans.

Maximum loads @ 25,000 psi stress

Maximum allowable deflections and maximum uniform loads for all spans @ 25,000 psi material stress.

Reduced load for all 1/180 Span Deflection

For moderate deflections on the longer spans, reduced loads are listed which will produce a deflection equal to 1/180 of the span. When maximum loads do not induce deflections exceeding 1/180 x the span length reduced loads are not required.

Reduced load for 1/360 Span Deflection

For very slight deflections on the longer spans, reduced loads are listed which will produce a deflection equal to 1/360 of the span. When maximum loads do not induce deflections exceeding 1/360 x the span length reduced loads are not required.

CONCENTRATED LOADS

To obtain values for concentrated loads from Table 3, multiply uniform load by 0.5 and deflection by 1.25.

Slotted, Punched, or KO Channel

Reduce load rating 5%.

Long span deep beams

Support in a manner to prevent rotation at supports and tie between supports to prevent twist.

COLUMN LOADS

Allowable column loads given are for uniform axial loading with pinned ends. For eccentric loading or other end conditions reduce allowable loads according to standard engineering practice.

DYNAMIC LOADS

Allowable dynamic loads may be calculated by dividing the static loads shown in Table 3, by 2.08.

Maximum beam and column loading for special materials is multiplied with the following factors:

Channel Type	Beam Load	Column Load
Stainless Steel	1	1
Aluminum	0.33	0.33

Warning

Load tables, charts and design criteria provided in this catalogue are intended as guides only. Selection of proper product, installation intervals, erection, and placement are the responsibility of the user.

Pipe hanger products when improperly used as tools of erection have occasionally failed. The user is cautioned to use the product only as it was intended to avoid an accident.

Thomas & Betts reserves the right to change material and finish specifications without notice, to improve its products.

Design Data – Metal Framing Channel
TABLE 3 (cont'd.)

SINGLE CHANNEL								DOUBLE CHANNEL (Single Channels welded back-to-back)											
Cat. No.	Depth	Ga.	Maximum Uniform		1/180 Span		1/360 Span		Col. Load	Cat. No.	Depth	Ga.	Maximum Uniform		1/180 Span		1/360 Span		Col. Load
			Load	Defl.	Load	Defl.	Load	Defl.					Load	Defl.	Load	Defl.	Load	Defl.	
12" BEAM OR COLUMN																			
A1200	1-5/8	12	3,534	.014	.067	.033	10,533		A1202	3-1/4	12		.008	.067	.033	21,177			
B1200	13/16	12	1,050	.026	.067	.033	6,683		B1202	1-5/8	12	3,016	.016	.067	.033	14,110			
C1200	1-3/8	12	2,584	.016	.067	.033	9,345		C1202	2-3/4	12		.010	.067	.033	18,990			
D1200	1	12	1,538	.022	.067	.033	8,670		D1202	2	12		.012	.067	.033	18,312			
E1200	2-7/16	12	6,650	.010	.067	.033	13,830		E1202	4-7/8	12		.005	.067	.033	27,623			
H1200	3-1/4	12	10,583	.008	.067	.033	17,106		H1202	6-1/2	12		.004	.067	.033	34,210			
A1400	1-5/8	14	2,434	.015	.067	.033	7,575		A1402	3-1/4	14		.008	.067	.033	15,250			
B1400	13/16	14	850	.028	.067	.033	4,950		B1402	1-5/8	14	2,300	.016	.067	.033	10,390			
18" BEAM OR COLUMN																			
A1200	1-5/8	12	2,355	.033	.100	.050	10,2100		A1202	3-1/4	12		.018	.100	.050	20,609			
B1200	13/16	12	700	.059	.100	.050	6,058		B1202	1-5/8	12	2,011	.036	.100	.050	13,440			
C1200	1-3/8	12	1,723	.038	.100	.050	8,970		C1202	2-3/4	12	4,811	.021	.100	.050	18,470			
D1200	1	12	1,025	.052	.100	.050	7,930		D1202	2	12		.028	.100	.050	17,942			
E1200	2-7/16	12	4,434	.023	.100	.050	13,482		E1202	4-7/8	12		.013	.100	.050	16,926			
H1200	3-1/4	12	7,055	.016	.100	.050	16,693		H1202	6-1/2	12		.009	.100	.050	33,390			
A1400	1-5/8	14	1,623	.031	.100	.050	7,334		A1402	3-1/4	14		.018	.100	.050	14,867			
B1400	13/16	14	566	.063	.100	.050	4,150		B1402	1-5/8	14	1,534	.036	.100	.050	9,910			
24" BEAM OR COLUMN																			
A1200	1-5/8	12	1,766	.058	.133	.067	9,842		A1202	3-1/4	12	4,858	.031	.133	.067	19,974			
B1200	13/16	12	525	.105	.133	.067	5,315		B1202	1-5/8	12	1,509	.064	.133	.067	12,670			
C1200	1-3/8	12	1,291	.066	.133	.067	8,545		C1202	2-3/4	12	3,609	.038	.133	.067	17,890			
D1200	1	12	769	.087	.133	.067	7,050		D1202	2	12	2,680	.042	.133	.067	17,160			
E1200	2-7/16	12	3,325	.039	.133	.067	13,082		E1202	4-7/8	12		.021	.133	.067	26,143			
H1200	3-1/4	12	5,291	.030	.133	.067	16,277		H1202	6-1/2	12		.016	.133	.067	32,435			
A1400	1-5/8	14	1,216	.056	.133	.067	7,058		A1402	3-1/4	14	3,425	.033	.133	.067	14,426			
B1400	13/16	14	425	.110	.133	.067	4,000		B1402	1-5/8	14	1,150	.064	.133	.067	9,350			
30" BEAM OR COLUMN																			
A1200	1-5/8	12	1,414	.089	.167	.083	9,419		A1202	3-1/4	12	3,886	.049	.167	.083	19,261			
B1200	13/16	12	420	.164	.167	.083	4,465		B1202	1-5/8	12	1,206	.100	.167	.083	11,803			
C1200	1-3/8	12	1,034	.104	.167	.083	8,060		C1202	2-3/4	12	2,886	.059	.167	.083	17,230			
D1200	1	12	615	.129	.167	.083	6,650		D1202	2	12	2,128	.084	.167	.083	16,480			
E1200	2-7/16	12	2,660	.063	.167	.083	12,640		E1202	4-7/8	12	7,806	.034	.167	.083	25,259			
H1200	3-1/4	12	4,234	.046	.167	.083	15,698		H1202	6-1/2	12		.025	.167	.083	31,395			
A1400	1-5/8	14	974	.088	.167	.083	6,753		A1402	3-1/4	14	2,740	.050	.167	.083	13,937			
B1400	13/16	14	340	.172	.167	.083	3,420		B1402	1-5/8	14	920	.100	.167	.083	8,730			

When no numbers are shown, use the maximum uniform load.
Deflections are given in inches; loads in lb

Design Data – Metal Framing Channel
TABLE 3 (cont'd.)

SINGLE CHANNEL							DOUBLE CHANNEL (Single Channels welded back-to-back)								
Cat. No.	Depth	Ga.	Maximum Uniform Load	1/180 Span Defl.	1/360 Span Defl.	Col. Load	Cat. No.	Depth	Ga.	Maximum Uniform Load	1/180 Span Defl.	1/360 Span Defl.	Col. Load		
36" BEAM OR COLUMN															
A1200	1-5/8	12	1,178	.129	.200	917	A1202	3-1/4	12	3,239	.071	.200	.100	18,470	
B1200	13/16	12	350	.236	.200	148	B1202	1-5/8	12	1,005	.144	.200	702	.100	10,840
C1200	1-3/8	12	861	.149	.200	578	C1202	2-3/4	12	2,400	.085	.200	.100	16,500	
D1200	1	12	513	.198	.200	217	D1202	2	12	1,428	.114	.200	1248	.100	15,057
E1200	2-7/16	12	2,216	.088	.200	.100	E1202	4-7/8	12	6,505	.048	.200	.100	24,316	
H1200	3-1/4	12	3,528	.068	.200	.100	H1202	6-1/2	12	.036	.200	.100	30,265		
A1400	1-5/8	14	811	.126	.200	640	A1402	3-1/4	14	2,284	.071	.200	.100	13,416	
B1400	13/16	14	284	.248	.200	115	B1402	1-5/8	14	766	.144	.200	535	.100	8,050
42" BEAM OR COLUMN															
A1200	1-5/8	12	1,010	.175	.233	674	A1202	3-1/4	12	2,776	.098	.233	.117	17,635	
B1200	13/16	12	300	.323	.233	109	B1202	1-5/8	12	863	.195	.233	516	.117	9,790
C1200	1-3/8	12	738	.203	.233	425	C1202	2-3/4	12	2,063	.115	.233	.117	15,730	
D1200	1	12	440	.264	.233	160	D1202	2	12	1,224	.166	.233	1069	.117	13,042
E1200	2-7/16	12	1,900	.120	.233	.117	E1202	4-7/8	12	5,576	.065	.233	.117	23,272	
H1200	3-1/4	12	3,024	.091	.233	.117	H1202	6-1/2	12	.049	.233	.117	29,025		
A1400	1-5/8	14	695	.160	.233	470	A1402	3-1/4	14	1,958	.225	.233	.117	12,832	
B1400	13/16	14	243	.336	.233	84	B1402	1-5/8	14	658	.195	.233	393	.117	7,300
48" BEAM OR COLUMN															
A1200	1-5/8	12	884	.228	.267	516	A1202	3-1/4	12	2,429	.128	.267	.133	16,730	
B1200	13/16	12	263	.420	.267	83	B1202	1-5/8	12	754	.255	.267	395	.133	8,640
C1200	1-3/8	12	646	.265	.267	325	C1202	2-3/4	12	1,804	.151	.267	.133	14,890	
D1200	1	12	384	.352	.267	122	D1202	2	12	1,071	.203	.267	702	.133	11,387
E1200	2-7/16	12	1,663	.156	.267	.133	E1202	4-7/8	12	4,879	.085	.267	.133	22,170	
H1200	3-1/4	12	2,646	.120	.267	.133	H1202	6-1/2	12	.064	.267	.133	27,700		
A1400	1-5/8	14	609	.120	.267	360	A1402	3-1/4	14	1,713	.128	.267	.133	12,223	
B1400	13/16	14	213	.440	.267	64	B1402	1-5/8	14	575	.255	.267	301	.133	6,480
54" BEAM OR COLUMN															
A1200	1-5/8	12	785	.289	.300	408	A1202	3-1/4	12	2,159	.161	.300	.150	15,763	
B1200	13/16	12	234	.533	.300	66	B1202	1-5/8	12	670	.323	.300	312	.150	7,405
C1200	1-3/8	12	574	.335	.300	257	C1202	2-3/4	12	1,604	.190	.300	1,263	.150	13,990
D1200	1	12	341	.466	.300	96	D1202	2	12	952	.266	.300	624	.150	10,391
E1200	2-7/16	12	1,478	.198	.300	1,123	E1202	4-7/8	12	4,338	.108	.300	.150	20,980	
H1200	3-1/4	12	2,351	.151	.300	.150	H1202	6-1/2	12	7,149	.081	.300	.150	16,280	
A1400	1-5/8	14	541	.286	.300	284	A1402	3-1/4	14	1,523	.161	.300	.150	11,566	
B1400	13/16	14	189	.556	.300	51	B1402	1-5/8	14	511	.323	.300	238	.150	5,580

When no numbers are shown, use the maximum uniform load.
Deflections are given in inches; loads in lb

Design Data – Metal Framing Channel
TABLE 3 (cont'd.)

SINGLE CHANNEL									DOUBLE CHANNEL (Single Channels welded back-to-back)										
Cat. No.	Depth	Ga.	Maximum Uniform		1/180 Span		1/360 Span		Col. Load	Cat. No.	Depth	Ga.	Maximum Uniform		1/180 Span		1/360 Span		Col. Load
			Load	Defl.	Load	Defl.	Load	Defl.					Load	Defl.	Load	Defl.	Load	Defl.	
60" BEAM OR COLUMN																			
A1200	1-5/8	12	706	.358	.333	330	.167	6,762	A1202	3-1/4	12	1,944	.199	.333	.167	14,738			
B1200	13/16	12	210	.658	107	.333	53	.167	-	B1202	1-5/8	12	604	.398	.333	253	.167	6,100	
C1200	1-3/8	12	516	.414	.333	208	.167	4,920	C1202	2-3/4	12	1,444	.235	.333	1,023	.167	13,050		
D1200	1	12	308	.550	157	.333	78	.167	1,561	D1202	2	12	257	.318	.333	449	.167	7,531	
E1200	2-7/16	12	1,330	.244	.333	909	.167	9,874	E1202	4-7/8	12	3,904	.133	.333	.167	19,734			
H1200	3-1/4	12	2,116	.186	.333	.167	12,406	H1202	6-1/2	12	6,434	.100	.333	.167	24,810				
A1400	1-5/8	14	486	.353	.333	231	.167	4,792	A1402	3-1/4	14	1,370	.199	.333	.167	10,878			
B1400	13/16	14	170	.687	82	.333	41	.167	-	B1402	1-5/8	14	460	.399	.333	193	.167	4,640	
66" BEAM OR COLUMN																			
A1200	1-5/8	12	643	.432	.367	273	.183	6,127	A1202	3-1/4	12	1,766	.240	.367	1,347	.183	13,646		
B1200	13/16	12	191	.795	88	.367	44	.183	-	B1202	1-5/8	12	549	.481	418	.367	209	.183	5,055
C1200	1-3/8	12	470	.501	344	.367	172	.183	4,145	C1202	2-3/4	12	1,313	.285	.367	846	.183	12,030	
D1200	1	12	280	.675	129	.367	65	.183	1,280	D1202	2	12	779	.377	593	.367	360	.183	6,581
E1200	2-7/16	12	1,210	.295	.367	753	.183	9,211	E1202	4-7/8	12	3,549	.180	.367	.183	18,415			
H1200	3-1/4	12	1,924	.226	.367	.183	11,616	H1202	6-1/2	12	5,849	.120	.367	.183	23,230				
A1400	1-5/8	14	443	.426	.367	190	.183	4,311	A1402	3-1/4	14	1,245	.241	.367	949	.183	10,133		
B1400	13/16	14	155	.831	68	.367	35	.183	-	B1402	1-5/8	14	419	.483	318	.367	159	.183	3,840
72" BEAM OR COLUMN																			
A1200	1-5/8	12	589	.514	459	.400	299	.200	5,436	A1202	3-1/4	12	1,620	.286	.400	1,132	.200	12,500	
B1200	13/16	12	175	.946	74	.400	37	.200	-	B1202	1-5/8	12	503	.574	351	.400	176	.200	4,230
C1200	1-3/8	12	430	.595	289	.400	144	.200	3,485	C1202	2-3/4	12	1,203	.339	.400	710	.200	10,980	
D1200	1	12	256	.792	108	.400	54	.200	1,084	D1202	2	12	714	.457	468	.400	312	.200	5,230
E1200	2-7/16	12	1,108	.351	.400	632	.200	8,509	E1202	4-7/8	12	3,253	.191	.400	.200	17,023			
H1200	3-1/4	12	1,839	.269	.400	1,313	.200	10,782	H1202	6-1/2	12	5,361	.143	.400	.200	21,560			
A1400	1-5/8	14	405	.506	320	.400	160	.200	3,809	A1402	3-1/4	14	1,141	.286	.400	798	.200	9,340	
B1400	13/16	14	141	.989	57	.400	29	.200	-	B1402	1-5/8	14	384	.574	267	.400	134	.200	3,220
84" BEAM OR COLUMN																			
A1200	1-5/8	12	505	.700	337	.467	168	.233	4,061	A1202	3-1/4	12	1,388	.390	.467	832	.233	9,992	
B1200	13/16	12			54	.467	27	.233	-	B1202	1-5/8	12	431	.780	258	.467	129	.233	3,100
C1200	1-3/8	12	369	.811	212	.467	106	.233	2,565	C1202	2-3/4	12	1,031	.461	.467	522	.233	8,670	
D1200	1	12	220	1.079	92	.467	58	.233	796	D1202	2	12	612	.623	344	.467	229	.233	3,842
E1200	2-7/16	12	950	.479	.467	464	.233	6,991	E1202	4-7/8	12	2,788	.260	.467	.233	13,993			
H1200	3-1/4	12	1,513	.366	.467	965	.233	8,988	H1202	6-1/2	12	4,595	.195	.467	.233	17,975			
A1400	1-5/8	14	348	.691	235	.467	118	.233	2,827	A1402	3-1/4	14	979	.390	.467	586	.233	7,682	
B1400	13/16	14			42	.467	21	.233	-	B1402	1-5/8	14	329	.781	197	.467	98	.233	2,370

When no numbers are shown, use the maximum uniform load.
Deflections are given in inches; loads in lb

Design Data – Metal Framing Channel
TABLE 3 (cont'd.)

SINGLE CHANNEL										DOUBLE CHANNEL (Single Channels welded back-to-back)									
Cat. No.	Depth	Ga.	Maximum Uniform		1/180 Span		1/360 Span		Col. Load	Cat. No.	Depth	Ga.	Maximum Uniform		1/180 Span		1/360 Span		Col. Load
			Load	Defl.	Load	Defl.	Load	Defl.					Load	Defl.	Load	Defl.	Load	Defl.	
96" BEAM OR COLUMN																			
A1200	1-5/8	12	441	.914	258	.533	129	.267	3,108	A1202	3-1/4	12	1,215	.509	.533	637	.267	7,675	
B1200	13/16	12			42	.533	21	.267	-	B1202	1-5/8	12	378	1.019	197	.533	99	.267	-
C1200	1-3/8	12	323	1.059	163	.533	81	.267	1,960	C1202	2-3/4	12	903	.603	.533	400	.267	6,640	
D1200	1	12	192	1.40	998	.533	49	.267	-	D1202	2	12	535	.813	263	.533	176	.267	2,942
E1200	2-7/16	12	831	.730		.533	355	.267	5,423	E1202	4-7/8	12	2,440	.340	.533	1,917	.267	10,875	
H1200	3-1/4	12	1,323	.478		.533	739	.267	7,059	H1202	6-1/2	12	4,021	.255	.533		.267	14,120	
A1400	1-5/8	14	304	.903	180	.533	90	.267	2,615	A1402	3-1/4	14	856	.509	.533	449	.267	5,951	
B1400	13/16	14			32	.533	16	.267	-	B1402	1-5/8	14	288	1.020	150	.533	75	.267	-
108" BEAM OR COLUMN																			
A1200	1-5/8	12	393	1.156	204	.600	102	.300	2,456	A1202	3-1/4	12	1,080	.644	.600	503	.300	6,071	
B1200	13/16	12			33	.600	16	.300	-	B1202	1-5/8	12	355	1.290	156	.600	78	.300	-
C1200	1-3/8	12	288	1.350	128	.600	64	.300	-	C1202	2-3/4	12	801	.763	632	.600	316	.300	5,250
D1200	1	12	171	1.783	76	.600	38	.300	-	D1202	2	12	476	1.029	208	.600	139	.300	2,324
E1200	2-7/16	12	739	.790	561	.600	281	.300	4,291	E1202	4-7/8	12	2,169	.430	.600	1,515	.300	8,599	
H1200	3-1/4	12	1,176	.605		.600	584	.300	5,579	H1202	6-1/2	12	3,574	.323	.600		.300	11,160	
A1400	1-5/8	14	270	1.141	142	.600	71	.300	1,708	A1402	3-1/4	14	761	.644	.600	355	.300	4,702	
B1400	13/16	14			25	.600	13	.300	-	B1402	1-5/8	14	255	1.290	119	.600	59	.300	-
120" BEAM OR COLUMN																			
A1200	1-5/8	12	354	1.425	165	.667	83	.333	-	A1202	3-1/4	12	971	.795	.667	408	.333	-	
B1200	13/16	12			27	.667	13	.333	-	B1202	1-5/8	12	301	1.588	126	.667	63	.333	-
C1200	1-3/8	12	259	1.663	104	.667	52	.333	-	C1202	2-3/4	12	721	.941	512	.667	256	.333	4,250
D1200	1	12	154	2.202	62	.667	31	.333	-	D1202	2	12	428	1.271	168	.667	112	.333	1,883
E1200	2-7/16	12	665	.976	455	.667	227	.333	3,478	E1202	4-7/8	12	1,951	.531	.667	1,227	.333	6,946	
H1200	3-1/4	12	1,059	.746		.667	473	.333	4,521	H1202	6-1/2	12	3,216	.398	.667		.333	9,040	
A1400	1-5/8	14	244	1.413	114	.667	57	.333	-	A1402	3-1/4	14	685	.796	.667	287	.333	3,805	
B1400	13/16	14			21	.667	10	.333	-	B1402	1-5/8	14	230	1.600	96	.667	48	.333	-
144" BEAM OR COLUMN																			
A1200	1-5/8	12			115	.800	57	.400	-	A1202	3-1/4	12	810	1.145	566	.800	283	.400	-
-										B1202	1-5/8	12			88	.800	44	.400	-
C1200	1-3/8	12			72	.800	36	.400	-	C1202	2-3/4	12	601	1.350	355	.800	178	.400	-
E1200	2-7/16	12	554	1.400	315	.800	158	.400	-	E1202	4-7/8	12	1,626	.764	.800	852	.400	-	
H1200	3-1/4	12	883	1.075	657	.800	328	.400	-	H1202	6-1/2	12	2,680	.573	.800	1,873	.400	-	
A1400	1-5/8	14			80	.800	40	.400	-	A1402	3-1/4	14	571	1.146	399	.800	199	.400	-
-										B1402	1-5/8	14			67	.800	33	.400	-

When no numbers are shown, use the maximum uniform load.
Deflections are given in inches; loads in lb

**Design Data – Metal Framing Channel
TABLE 3 (cont'd.)**

SINGLE CHANNEL							DOUBLE CHANNEL (Single Channels welded back-to-back)												
Cat. No.	Depth	Ga.	Maximum		1/180		1/360		Col. Load	Cat. No.	Depth	Ga.	Maximum		1/180		1/360		Col. Load
			Uniform Load	Defl.	Span Load	Defl.	Span Load	Defl.					Uniform Load	Defl.	Span Load	Defl.	Span Load	Defl.	
168" BEAM OR COLUMN																			
A1200	1-5/8	12			84	.933	42	.467	-	A1202	3-1/4	12	694	1.563	916	.933	208	.467	-
-										B1202	1-5/8	12			64	.933	32	.467	-
C1200	1-3/8	12			53	.933	27	.467	-	C1202	2-3/4	12	515	1.850	261	.933	130	.467	-
E1200	2-7/16	12	475	1.912	233	.933	116	.467	-	E1202	4-7/8	12	1,394	1.040	1,255	.933	626	.467	-
H1200	3-1/4	12	756	1.463	482	.933	241	.467	-	H1202	6-1/2	12	2,298	.780		.933	1,326	.467	-
A1400	1-5/8	14			60	.933	30	.467	-	A1402	3-1/4	14	489	1.563	293	.933	147	.467	-
-										B1402	1-5/8	14			49	.933	25	.467	-
192" BEAM OR COLUMN																			
-										A1202	3-1/4	12			318	1.07	159	.533	-
-										-									-
-										C1202	2-3/4	12			200	1.07	100	.533	-
E1200	2-7/16	12			178	1.07	89	.533	-	E1202	4-7/8	12	1,220	1.363	958	1.07	479	.533	-
H1200	3-1/4	12	661	1.91	369	1.07	185	.533	-	H1202	6-1/2	12	2,010	1.019		1.07	1,053	.533	-
-										A1402	3-1/4	14			224	1.07	112	.533	-
-										-									-
216" BEAM OR COLUMN																			
-										A1202	3-1/4	12			252	1.20	126	.600	-
-										-									-
-										C1202	2-3/4	12			158	1.20	79	.600	-
E1200	2-7/16	12			140	1.20	70	.600	-	E1202	4-7/8	12	1,084	1.725	757	1.20	379	.600	-
H1200	3-1/4	12			292	1.20	146	.600	-	H1202	6-1/2	12	1,788	1.288		1.20	832	.600	-
-										A1402	3-1/4	14			177	1.20	89	.600	-
-										-									-
240" BEAM OR COLUMN																			
-										A1202	3-1/4	12			204	1.33	102	.667	-
-										-									-
-										C1202	2-3/4	12			128	1.33	64	.667	-
E1200	2-7/16	12			114	.334	57	.667	-	E1202	4-7/8	12			613	1.33	307	.667	-
H1200	3-1/4	12			236	.334	118	.667	-	H1202	6-1/2	12	1,609	1.588		1.33	674	.667	-
-										A1402	3-1/4	14			144	1.33	72	.667	-
-										-									-

When no numbers are shown, use the maximum uniform load.
Deflections are given in inches; loads in lb

Design Data – Metal Framing Channel

TABLE 4

Safe bearing loads for 1-5/8" channel and combinations.

Safety factor of 2-1/2

					
Section	Recommended Load in lb	Section	Recommended Load in lb	Section	Recommended Load in lb
A1200	5000	A1200	3500	A1200	8000
A1400	3500	A1400	2500	A1400	5500
B1200	6000	B1200	4000	B1200	9000
B1400	3400	B1400	2600	B1400	4800
C1200	5000	C1200	3500	C1200	8000
E1200	5000	E1200	3500	E1200	8000
H1200	4000	H1200	2000	H1200	5500

TABLE 5

Design load table for typical channel connections.

Safety factor of 2-1/2 based on ultimate strength of the connection. Load diagrams indicate up to three design loads, for 12 gauge and 14 gauge channel applications.

90° Fittings (When used in position shown)

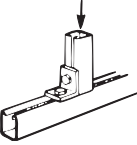
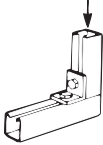
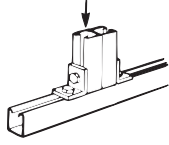
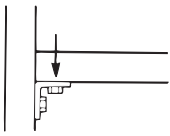
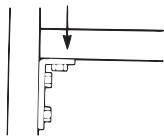
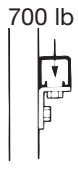
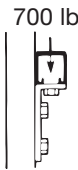
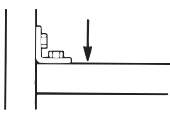
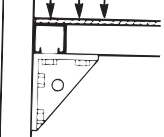
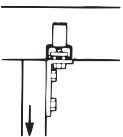
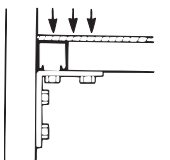
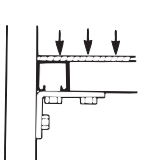
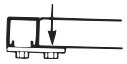
 <p>Both ends supported</p>	 <p>Both ends supported</p>	 <p>700 lb</p>	 <p>700 lb</p>
<p>AB202 A1200 1500 lb A1400 1000 lb</p>	<p>AB203 A1200 2000 lb A1400 1500 lb</p>	<p>AB201</p>	<p>AB203</p>
 <p>Both ends supported</p>	 <p>Both ends supported</p>		
<p>AB202 A1200 1000 lb A1400 650 lb</p>	<p>AB213 A1200 3000 lb AB214 A1400 2000 lb</p>	<p>AB20 1500 lb</p>	
 <p>Both ends supported</p>	 <p>Both ends supported</p>	<p>Flat Plate Fittings</p>	
<p>AB205 A1200 2000 lb AB216 A1400 2000 lb</p>	<p>AB204 A1200 1500 lb AB215 A1400 1000 lb</p>		<p>Both ends supported</p>
		<p>AB206 A1200 1000 lb A1400 800 lb</p>	

**Design Applications
CANTILEVER BEAMS**

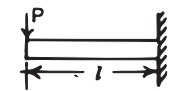

$V_{max.} = P$
 $M_{max.} = Pl$



$\Delta_{max.} = \frac{Pl^3}{3EI}$

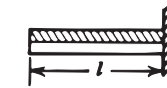

$V_{max.} = W$
 $M_{max.} = \frac{Wl}{2}$
 $\Delta_{max.} = \frac{Wl^3}{8EI}$

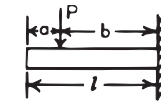

$V_{max.} = P$
 $M_{max.} = Pb$
 $\Delta_{max.} = \frac{Pb^2(3l-b)}{6EI}$



SIMPLE BEAMS

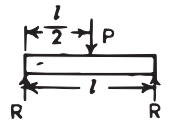

$R = \frac{P}{2}$
 $V_{max.} = \frac{P}{2}$
 $M_{max.} = \frac{Pl}{4}$
 $\Delta_{max.} = \frac{Pl^3}{48EI}$

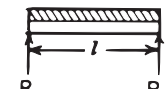

$R = \frac{W}{2}$
 $V_{max.} = \frac{W}{2}$
 $M_{max.} = \frac{Wl}{8}$
 $\Delta_{max.} = \frac{5Wl^4}{384EI}$

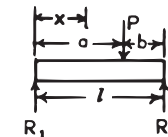

$R_1 = \frac{Pb}{l}$
 $R_2 = \frac{Pa}{l}$
 $V_{max.} = \frac{Pa}{l}$
 $M_{max.} = \frac{Pab}{l}$



$\Delta_{max.} \text{ at } x = \sqrt{\frac{a(a+2b)}{3}}$
 $\Delta_{max.} = \frac{Pab(a+2b)\sqrt{3a(a+2b)}}{27EI}$

BEAMS FIXED ON ONE END, SUPPORTED AT OTHER

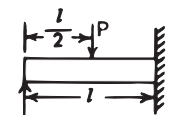

$R_1 = \frac{5P}{16}$
 $V_{max.} = \frac{11P}{16}$
 $M_{max.} = \frac{3Pl}{16}$



$\Delta_{max.} \text{ at } x = 0.447l$
 $\Delta_{max.} = 0.009317 \frac{Pl^3}{EI}$

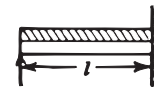

$R_1 = \frac{3W}{8}$
 $V_{max.} = \frac{5W}{8}$
 $M_{max.} = \frac{Wl}{8}$



$\Delta_{max.} \text{ at } x = 0.4215l$
 $\Delta_{max.} = \frac{Wl^3}{185EI}$

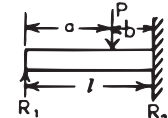

$R_1 = \frac{Pb^2}{2l^3}(a+2l)$
 $R_2 = \frac{Pa}{2l^3}(3l^2-a^2)$



M at point of load = $R_1 a$
M at fixed end = $\frac{Pab}{2l^2}(a+l)$

BEAMS FIXED AT BOTH ENDS

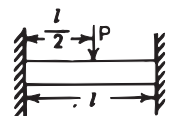

$V_{max.} = \frac{P}{2}$
 $M_{max.} = \frac{Pl}{8}$
 $\Delta_{max.} = \frac{Pl^3}{192EI}$

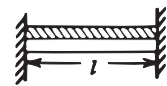

$V_{max.} = \frac{W}{2}$
 $M_{max.} = \frac{Wl}{12}$
 $\Delta_{max.} = \frac{Wl^4}{384EI}$

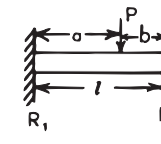

$R_1 = \frac{Pb^2}{l^3}(3a+b)$
 $R_2 = \frac{Pa^2}{l^3}(a+3b)$



$M_1 = \frac{Pab^2}{l^2}$
 $M_2 = \frac{Pa^2b}{l^2}$

R - Reaction
M - Moment
P - Concentrated load

W - Total uniform load
V - Shear

Δ - Deflection
E - Modulus of Elasticity
I - Moment of Inertia







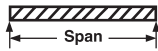

Design Applications

TABLE 6

Conversion Factors for Beams with Various Static Loading Conditions

Load tables on pages 104 through 108 for A, B, C, E, and H series channel are for single span beams supported at the ends. These can be used in the majority of cases. There are times when it is necessary to know what happens with other loading

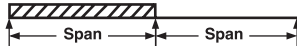
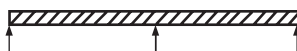
and support conditions. Some common arrangements are shown in Table 6. Simply multiply the loads from the Design Load Tables times the factors given in Table 6. Examples shown on page 112.

LOAD AND SUPPORT CONDITION	LOAD FACTOR	DEFLECTION FACTOR
1. Simple Beam - Uniform Load	1.00	1.00
		
2. Simple Beam - Concentrated Load at Center	.50	1.25
		
3. Simple Beam - Two Equal Concentrated Loads at 1/4 Points	1.00	1.10
		
4. Beam Fixed at Both Ends - Uniform Load	1.50	.30
		
5. Beam Fixed at Both Ends - Concentrated Load at Center	1.00	.40
		
6. Cantilever Beam - Uniform Load	.25	2.40
		
7. Cantilever Beam - Concentrated Load at End	.12	3.20
		
8. Continuous Beam - Two Equal Spans - Uniform Load on One Span	1.30	.92
		
9. Continuous Beam - Two Equal Spans - Uniform Load on Both Ends	1.00	.42
		
10. Continuous Beam - Two Equal Spans - Concentrated Load at Center of One Span	.62	.71
		
11. Continuous Beam - Two Equal Spans - Concentrated Load at Center of Both Spans	.67	.48
		

Design Applications

EXAMPLE I

PROBLEM:

Determine the load and deflection of an A1200 beam continuous over one support and loaded uniformly on one span.



SOLUTION:

- A. From load table 3 for A1200 the load for a 5'0" span is 706 lb and deflection is .358".
- B. Multiply by factors from Table 6.
 Load = 706 lb x 1.30 = 917.8 lb
 Deflection = .358 x .92 = .329"

COLUMN LOADING

The load bearing capacity of column or compression members is a function of the inherent configurational strength, the unbraced length and design of the end connections.

Values of axial column loading given in Table 3 were calculated using a rotationally free and translation fixed correction at each end (see illustration I). This gives an end condition constant (K) of 1.

ILLUSTRATION I

COLUMN HEIGHT

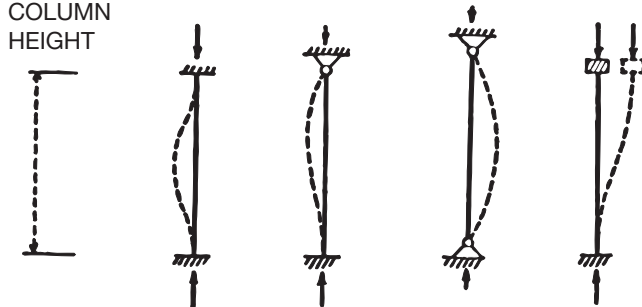

K value .65 .80 1.0 1.2

END CONDITION CODE

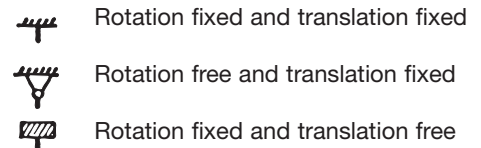

EXAMPLE II

PROBLEM:

Determine load and deflection of an E1200 cantilever beam with a concentrated load on the end.

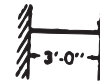

SOLUTION:

- A. From load table 3 for E1200 the load for a 3'0" span is 2216 lb and deflection is .088".
- B. Multiply by factors from Table 6.
 Load = 2216 lb x .12 = 265.9 lb
 Deflection = .088 x 3.20 = .282"

If other end conditions are used, axial loading should be calculated using procedures in the AISI specification for the design of cold formed steel structural members (SG671) and the engineering values for Superstrut® channel given in Table 1.

TABLE 7
Load Carrying Capacities of Hot Rolled Steel Rod

Nominal Rod Dia.	Root Area Thread	Design Load lb for Serv. Temperature	
		343°C (650°F)	399°C (750°F)
3/8	.068	610	540
1/2	.126	1130	1010
5/8	.202	1810	1610
3/4	.302	2710	2420
7/8	.419	3770	3360

Dimensions are in inches.
Safety factor of 5.

TABLE 8
Rod Size Determined by Pipe Size for Fire Protection

Pipe Size	Rod Size
3/4 to 2	3/8
2-1/2 to 3-1/2	1/2
4 to 5	5/8
6	3/4
8 to 12	7/8

Dimensions are in inches.

Design Applications

TABLE 9

Maximum Spacing between Pipe Supports

Steel Pipe																				
Nom. Pipe Size (inches)	1/2	3/4	1		1-1/2	2	2-1/2	3	3-1/2	4	5	6	8	10	12	14	16	18	20	24
Max. Spacing (feet)	5	6	7		9	10	11	12	13	14	16	17	19	22	23	25	27	28	30	32

Copper Pipe										
Nom. Pipe Size (inches)	1/2	3/4	1	1-1/4	1-1/2	2	2-1/2	3	3-1/2	4
Max. Spacing (feet)	5	6	6	7	8	9	10	10	11	12

TABLE 10

Minimum Spacing (inches) between Centers of Standard Pipe When Using Superstrut #702 Pipe Straps

Nom. Pipe Size (inches)	1/2	3/4	1	1-1/4	1-1/2	2	2-1/2	3	3-1/2	4	5	6	8
1/2	1-3/16												
3/4	1-5/16	1-7/16											
1	1-1/2	1-5/8	1-3/4										
1-1/4	1-3/4	1-7/8	2	2-1/4									
1-1/2	1-15/16	2-1/16	2-3/16	2-7/16	2-9/16								
2	2-3/16	2-5/16	2-1/2	2-3/4	2-7/8	3-1/8							
2-1/2	2-7/16	2-9/16	2-3/4	3	3-1/8	3-3/8	3-5/8						
3	2-13/16	2-15/16	3-1/16	3-5/16	3-7/16	3-3/4	4	4-5/16					
3-1/2	3-1/8	3-1/4	3-3/8	3-5/8	3-3/4	4-1/16	4-5/16	4-5/8	4-15/16				
4	3-7/16	3-9/16	3-15/16	4-1/16	4-3/8	4-5/8	4-15/16	5-1/4	5-9/16				
6	4-3/4	4-7/8	5	5-1/4	5-3/8	5-5/8	5-7/8	6-3/16	6-1/2	6-13/16	7-7/16	8-1/8	
8	5-7/16	6	6-1/8	6-3/8	6-1/2	6-3/4	7	7-5/16	7-5/8	8	8-9/16	9-1/4	10-3/8

Design Applications

TABLE 11

Standard Dimensions and Weights of Piping Materials and Conduit

Mechanical (ANSI & API Standard, Schedule 40)				
Nominal Std. Pipe Size (inches)	Pipe O.D. (inches)	Coupling O.D. (inches)	Weights of Pipe lb/ft	Weight of Pipe Filled w/Water lb/ft
1/2	.84	1.06	.85	.98
3/4	1.05	1.31	1.13	1.36
1	1.32	1.58	1.68	2.05
1 - 1/4	1.66	1.90	2.27	2.92
1 - 1/2	1.90	2.20	2.72	3.60
2	2.38	2.75	3.65	5.11
2 - 1/2	2.88	3.25	5.79	7.87
3	3.50	4.00	7.58	10.78
3 - 1/2	4.00	4.63	9.11	13.39
4	4.50	5.00	10.79	16.30
5	5.56	6.30	14.62	23.28
6	6.63	7.39	18.97	31.48
8	8.63	9.23	28.56	50.24
10	10.75		41.00	74.00
12	12.75		50.00	99.00
14	14.00		64.00	122.00
16	16.00		63.00	142.00
18	18.00		71.00	172.00
20	20.00		79.00	205.00
22	22.00		87.00	240.00
24	24.00		95.00	277.00
26	26.00		103.00	322.00
28	28.00		111.00	364.00
30	30.00		119.00	410.00

Electrical Conduit					
Nominal Conduit Size	Rigid Steel			Thin Wall (EMT)	
	Conduit O.D. (inches)	Weight of Conduit lb/ft	Weight of Conduit w/Non-lead Covered Conductor lb/ft	Conduit O.D. (inches)	Weight of Conduit lb/ft
1/2	.84	.85	1.04	.71	.29
3/4	1.05	1.13	1.40	.92	.44
1	1.32	1.68	2.35	1.16	.64
1 - 1/4	1.66	2.28	3.58	1.51	.95
2	2.38	3.68	7.21	2.20	1.40
2 - 1/2	2.88	5.82	10.22	2.88	2.30
3	3.50	7.62	14.51	3.50	2.70
4	4.50	10.89	21.48	4.50	4.00

Includes weight of heaviest conductor combination.

SECTION 8

Engineering Data & Specifications

Design Applications

TABLE 12

Extra Strong Pipe (ANSI & API Standard, Schedule 80)

A.S.A. B36.10 SCHEDULE NOS. AND NOMINAL WALL THICKNESS DESIGNATIONS	Nominal Pipe Size (inches)	O.D. (inches)	Wall Thickness (inches)	I.D. (inches)	Weight of Pipe lb/ft	Water Weight per ft of Pipe lb	Weight of Pipe Filled w/Water lbs/ft
	3/8	.675	.126	.423	.74	.061	.801
	1/2	.840	.147	.546	1.09	.101	1.191
	3/4	1.050	.154	.742	1.47	.188	1.668
	1	1.315	.179	.957	2.17	.311	2.481
	1-1/4	1.660	.191	1.278	3.00	.555	3.555
EXTRA STRONG PIPE and SCHEDULE 80 PIPE (through 8")	1-1/2	1.900	.200	1.500	3.63	.765	4.395
	2	2.375	.218	1.939	5.03	1.279	6.309
	2-1/2	2.875	.276	2.323	7.66	1.834	9.497
	3	3.500	.300	2.900	10.30	2.860	13.160
	3-1/2	4.000	.318	3.364	12.55	3.850	16.350
	4	4.500	.337	3.826	15.00	4.980	19.980
	5	5.563	.375	4.813	20.80	7.890	28.690
	6	6.625	.432	5.761	28.60	11.290	39.890
	8	8.625	.500	7.625	43.40	19.790	63.200
EXTRA STRONG PIPE (10" through 24" OD)	10	10.750	.500	9.750	54.70	32.300	87.000
	12	12.750	.500	11.750	65.40	47.000	112.400
	14 OD	14.000	.500	13.000	72.10	57.500	129.600
	16 OD	16.000	.500	15.000	82.80	76.500	159.300
	18 OD	18.000	.500	17.000	93.50	98.400	191.900
	20 OD	20.000	.500	19.000	104.10	122.800	226.900
	24 OD	24.000	.500	23.000	125.50	180.100	305.600
SCHEDULE 80 PIPE (10" through 24" OD)	10	10.750	.593	9.564	64.300	31.100	95.400
	12	12.750	.687	11.376	88.50	44.000	132.500
	14 OD	14.000	.750	12.500	106.10	53.200	159.300
	16 OD	16.000	.842	14.314	136.50	69.700	206.200
	18 OD	18.000	.937	16.126	170.80	88.500	259.300
	20 OD	20.000	1.031	17.938	208.90	109.400	318.300
	24 OD	24.000	1.218	21.564	296.40	158.300	454.700

TABLE 13

Pipe Covering Weights (Thickness intended as guide, only)

Thickness and weight of calcium silicate covering.

Nominal Pipe Size	260°		360°		440°		525°		600°		700°		800°	
	Thick. (inches)	lb/ft	Thick. (inches)	lb/ft	Thick. (inches)	lb/ft	Thick. (inches)	lb/ft	Thick. (inches)	lb/ft	Thick. (inches)	lb/ft	Thick. (inches)	lb/ft
1	1	.68	1	.68	1	.68	1	.68	1-1/2	1.19	1-1/2	1.19	1-1/2	1.19
1-1/4	1	.75	1	.75	1	.75	1	.75	1-1/2	1.27	1-1/2	1.27	2	1.82
1-1/2	1	.88	1	.88	1	.88	1	.88	1-1/2	1.45	1-1/2	1.45	2	1.87
2	1	1.01	1	1.01	1	1.01	1-1/2	1.53	1-1/2	1.53	2	2.50	2	2.50
2-1/2	1	1.15	1	1.15	1	1.15	1-1/2	1.69	1-1/2	1.69	2	2.50	2-1/2	3.22
3	1	1.28	1	1.28	1	1.28	1-1/2	2.09	1-1/2	2.09	2	2.98	2-1/2	3.98
3-1/2	1	1.44	1	1.44	1-1/2	2.29	1-1/2	2.29	2	3.00	2	3.12	2-1/2	4.30
4	1	1.60	1	1.60	1-1/2	2.49	1-1/2	2.49	2	3.49	2	3.49	2-1/2	4.62
5	1	1.84	1	1.84	1-1/2	2.84	1-1/2	2.84	2	3.97	2	3.97	2-1/2	5.92
6	1-1/2	3.13	1-1/2	3.13	1-1/2	3.13	1-1/2	3.13	2	4.54	2	4.54	2-1/2	6.75
8	1-1/2	4.06	1-1/2	4.06	1-1/2	4.06	1-1/2	4.06	2	5.56	2	5.56	2-1/2	7.61

Design Applications

TABLE 14

Column Loading For Rack Construction

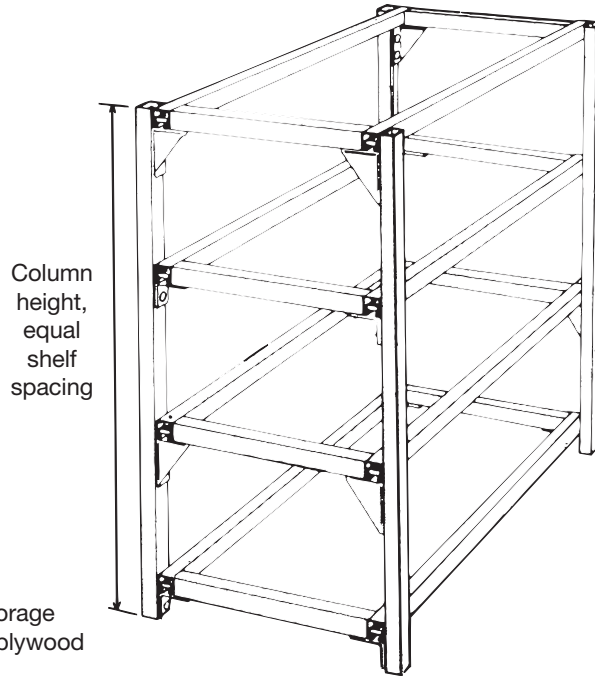

Typical general storage rack for use with plywood or other decking.

GENERAL STORAGE RACKS

PALLET RACKS

BARREL RACKS

BULK FURNITURE RACKS

CABLE RACKS

BAR STOCK RACKS

DISPLAY RACKS

SPECIAL PURPOSE RACKS

**For Uniform Loads on Horizontal Members
See Table 3**

ALLOWABLE LOAD IN LB PER UPRIGHT

Column Height	Cat. No.	NUMBER OF SHELVES PER UPRIGHT								
		2	3	4	5	6	7	8	9	10
6'	A1200	2237	1925	1650	1437	1290				
	A1202	4170	3580	3100	2730	2450				
	B1400	800	820	790	700	630				
	B1402	1930	1700	1500	1300	1190				
7'	A1200	2150	1850	1630	1425	1280	1150			
	A1202	4000	3525	3000	2700	2430	2200			
	B1400	650	790	760	685	615	550			
	B1402	1800	1650	1450	1300	1180	750			
8'	A1200	2000	1820	1600	1400	1250	1150	1050		
	A1202	3900	3475	3000	2700	2400	2185	2000		
	B1400	580	750	730	660	610	540	510		
	B1402	1650	1610	1450	1300	1160	940	970		
9'	A1200	1950	1780	1575	1400	1250	1130	1030	950	
	A1202	3800	3400	3020	2675	2400	2180	1975	1800	
	B1400		600	665	600	580	540	500	475	
	B1402	1500	1500	1430	1275	1160	1000	900	800	
10'	A1200	1870	1700	1500	1300	1200	1100	1000	900	800
	A1202	3600	3300	3000	2650	2350	2000	1975	1800	1650
	B1400		550	650	625	580	535	490	450	425
	B1402	1450	1480	1400	1250	1140	1040	960	885	825

Design Applications — Mechanical Support

Example 1

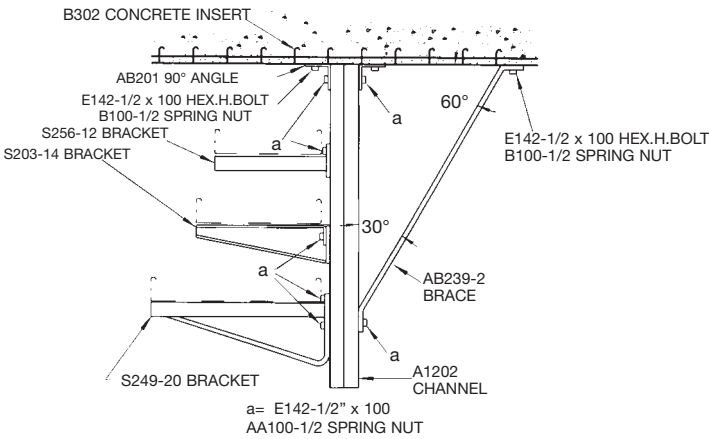

Suspended column, carrying brackets, braced to the ceiling.

Example 2

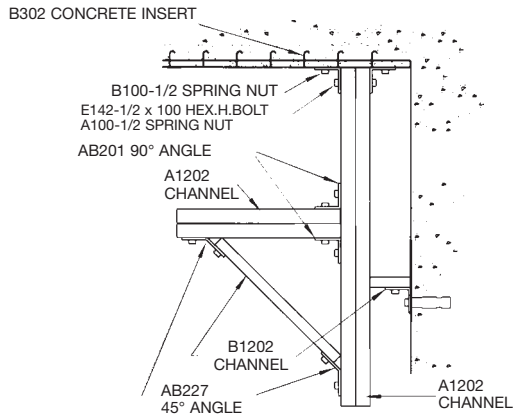

Suspended column, holding bracket and console braced to wall.

Example 3

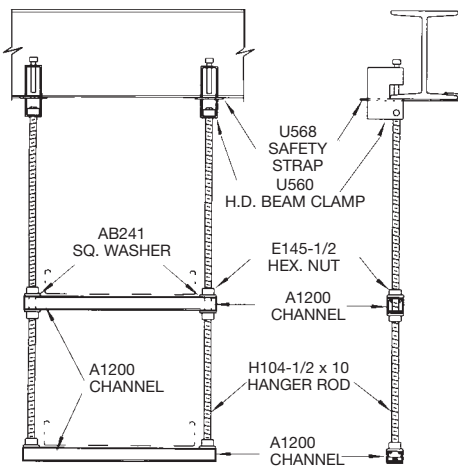

Trapeze with channels as cross members using beam clamps and hanger rods.

Example 4

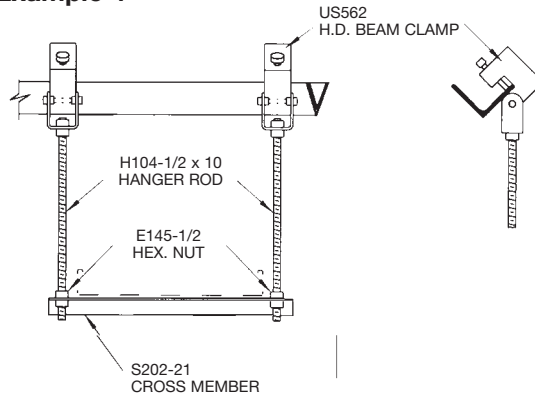

Sketch depicts the use of beam clamps on slanted beams.

Example 5

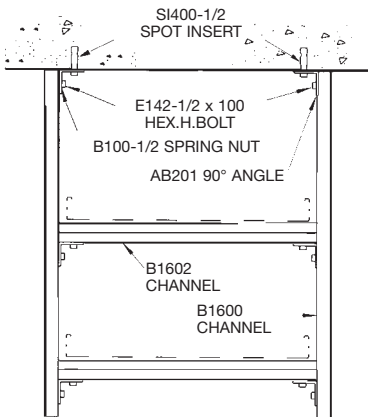

Trapeze, constructed from channels, fittings. The use of spot inserts is shown (SI400-1/2).

Example 6

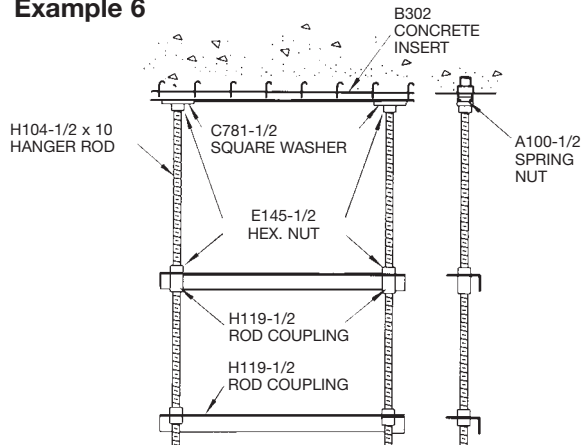

Trapeze with S202 cross members using hanger rods and concrete inserts.

Design Applications – Mechanical Support

Example 7

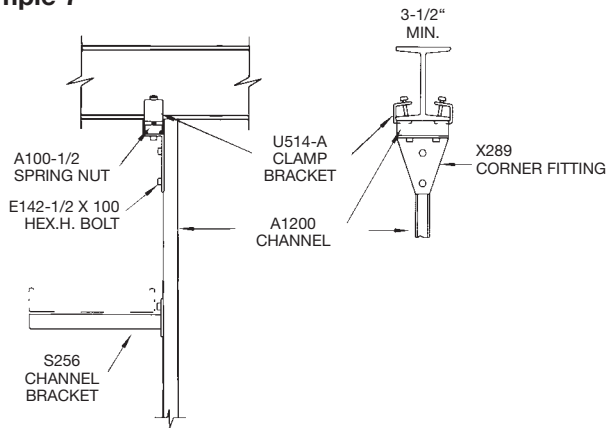

* NOTE: BRACE SHOULD BE USED FOR LENGTHS GREATER THEN 30"

Single-sided bracket application

Example 8

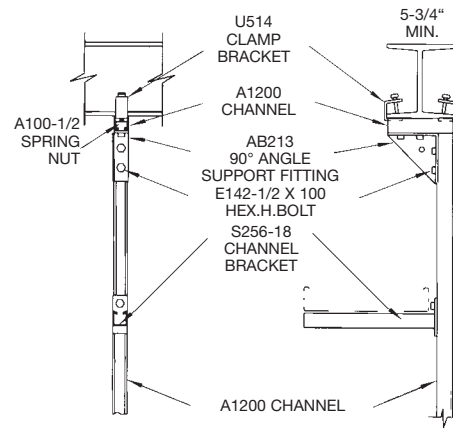

Single-sided bracket application

Example 9

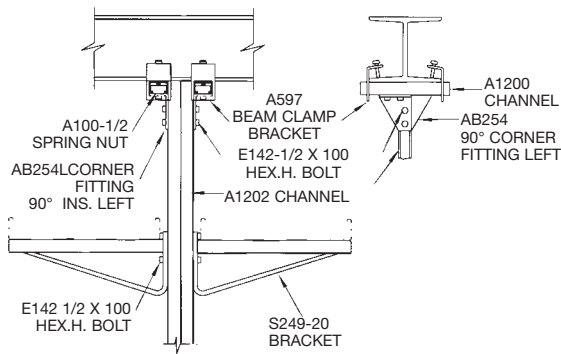

Two-sided heavy duty application

Example 10

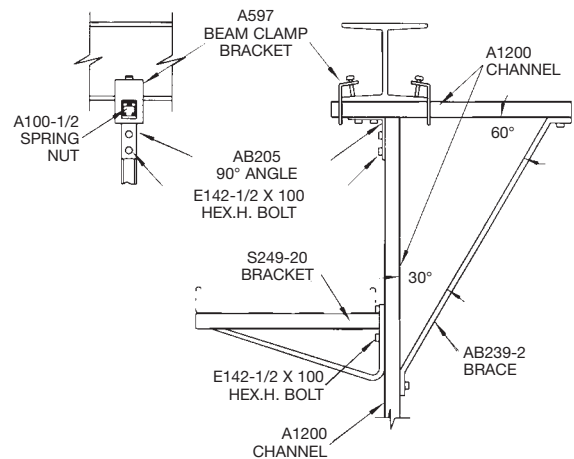

Heavy duty bracket application

Example 11

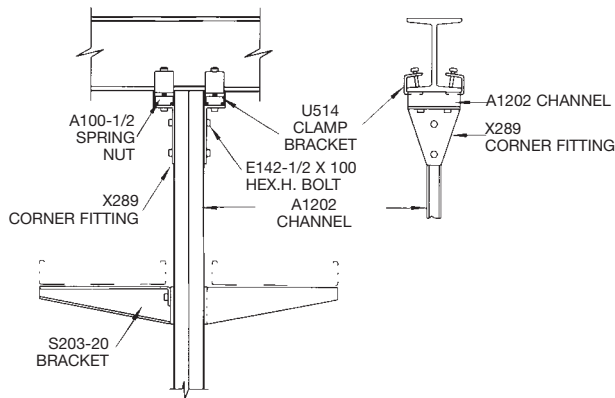

Brackets parallel to beam

Example 12

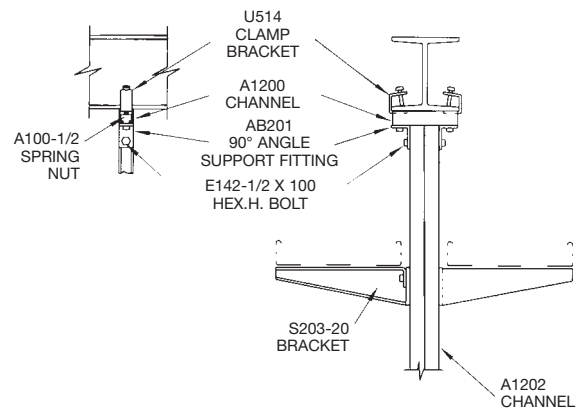

Brackets perpendicular to beam