

SECTION 4

Beam Clamps

Beam Clamps for Hanging Rod

U562 Beam Clamp

Optional Use of
U562HDG Beam Clamp

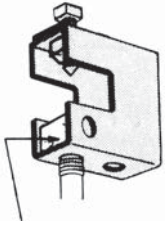

E146 square nut order separately.
1/2" set screw included.

Rod Size	Wt./C lb	Design Load lb
1/2	80	800

For 20° swivel application use ES-145-1/2 nut.

U562HDG
U562EG
U562
U562SS6

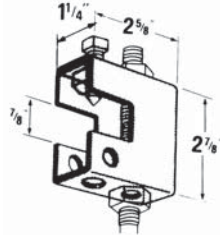

1/2" set screw included.

Rod Size	Wt./C lb	Design Load lb
1/2	80	500

UM562 Beam Clamp

UM562HDGC
UM562EG
UM562
UM562SS6

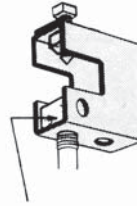

E146 square nut order separately.
1/2" set screw included.

Rod Size	Wt./C lb	Design Load lb
1/2	100	1200

For 20° swivel application use
ES-145-1/2 nut.

US562 Beam Clamp with Swing Hanger

US562HDG
US562EG
US562

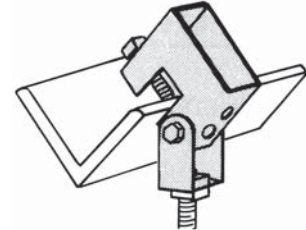

1/2" set screw included.

Rod Size	Wt./C lb	Design Load lb
1/2	113	800

U563 Beam Clamp

Optional Use of U563HDG Beam Clamp

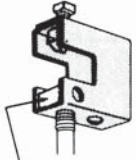

Square nut order separately
3/8" set screw included.

Rod Size	Wt./C lb	Design Load lb
3/8	33	400

U563HDG
U563EG
U563

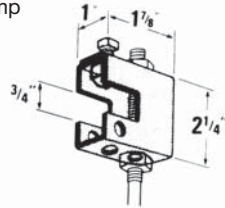

3/8" set screw included.

Rod Size	Wt./C lb	Design Load lb
3/8	33	240

US563 Beam Clamp with Swing Hanger

US563HDG
US563

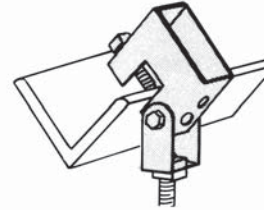

3/8" set screw included.

Rod Size	Wt./C lb	Design Load lb
3/8	50	400

U569 Beam Clamp

U569HDG
U569

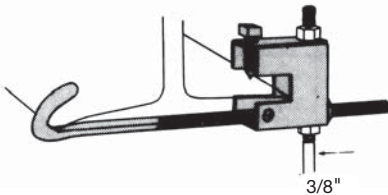

Maximum flange width 5".

Cat. No.	A Size	Wt./C lb	Design Load lb
U569	3/8	150	400

A570 Beam Clamp with Safety Rod

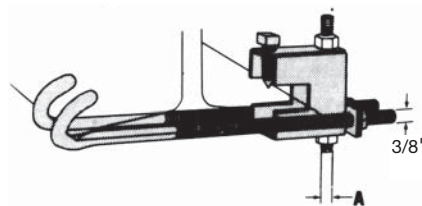

Flange width 4" min. - 8" max.
For use with 3/8" rod see U-569.

Cat. No.	A Size	Wt./C lb	Design Load lb
A570HDG	1/2	220	500

Beam Clamps

SECTION 4

Beam Clamps for Hanging Rod

U560
Heavy Duty
Beam Clamp

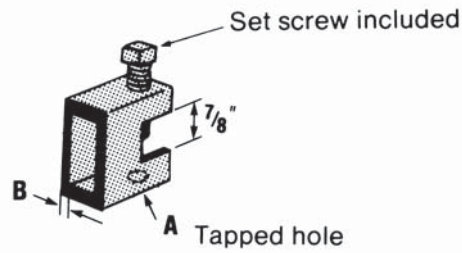

*Finishes
GoldGalv®
EG

Cat. No.	A	B	C	Wt./C lb	Design Load lb
U560-1/4*	1/4	1/8	3/8 x 1-1/2	67	1050
U560-3/8*	3/8	1/8	3/8 x 1-1/2	67	1050
U560-1/2*	1/2	1/4	1/2 x 1-1/2	130	2650
U560-5/8*	5/8	1/4	1/2 x 1-1/2	130	2650

U564
Heavy Duty Beam Clamp

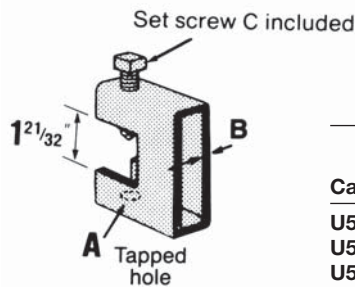

*Finishes
GoldGalv®
EG

Cat. No.	A	B	C	Wt./C lb	Design Load lb
U564-3/8*	3/8	1/8	3/8 x 2-3/4	109	1300
U564-1/2*	1/2	1/4	1/2 x 2-3/4	201	3150
U564-5/8*	5/8	1/4	1/2 x 2-3/4	201	3150

U568
Beam Clamp Safety Strap

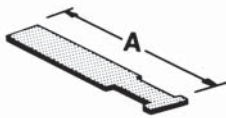

For U563 beam clamp.

Cat. No.	Beam Flange Width	A	Wt./C lb
U568-1EG	6	8	18
U568-2EG	9	11	28

16 gauge material

U568
Beam Clamp Safety Strap

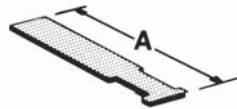

For U562 and UM562 beam clamp.

Cat. No.	Beam Flange Width	A	Wt./C lb
U568-3EG	6	9	25
U568-4EG	9	12	33
U568-5EG	12	15	42

16 gauge material

U568
Beam Clamp Safety Strap

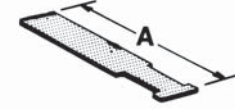

For U560 and U564 beam clamp.

Cat. No.	Beam Flange Width	A	Wt./C lb
U568-6EG	6	9	24
U568-7EG	9	12	31
U568-8EG	12	15	44

16 gauge material

C775L / M775L
Clamp with Lock Nut

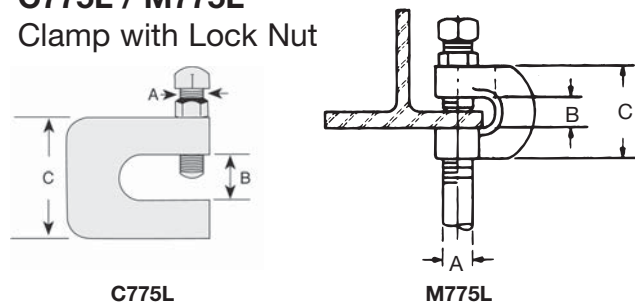

Standard Finish - Electrogalvanized (EG)

Malleable Iron (M775L)
Carbon Steel (C775L)

Cat. No.	Rod Size	Dimensions in.			Wt./C lb	Design Load lb
		A	B	C		
C775L-3/8EG	3/8	3/8	3/8	3/4	38	400
C775L-1/2EG	1/2	3/8	3/8	3/4	39	500
C775L-5/8EG	5/8	1/2	1/2	3/4	60	550
C775L-3/4EG	3/4	5/8	5/8	3/4	69	600
C775L-7/8EG	7/8	3/4	3/4	1	184	900
M775L-3/8EG	3/8	3/8	3/4	1-3/4	27	400
M775L-1/2EG	1/2	1/2	3/4	1-3/4	35	400
M775L-5/8EG	5/8	5/8	3/4	2	52	440
M775L-3/4EG	3/4	3/4	3/4	2	63	500

Complies to Specification MSS SP69, Type 23.

Materials	HDG(C) EG(C) (No suffix) SS6(C)	Hot-Dipped Galvanized Electrogalvanized GoldGalv® Stainless Steel 316
------------------	--	--

Beam Clamps for Hanging Rod

500SC, 502, 503SC, 507, 508, 509, 510, 511
Beam Clamp

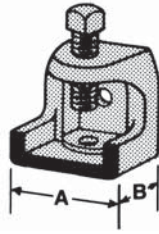

*Standard Finish -
Electrogalvanized (no suffix)*

Cat. No.	Tapped Holes	Base Dim. in.		Jaw Opening	Wt./C lb	Design Load lb
		A	B			
500SC	1/4 - 20	1	1-1/4	15/16	18	450
502	3/8 - 16	2	2	1	92	1300
503SC	1/2 - 13	2-5/8	2-1/2	1	164	1300
507	1/2 - 13	2-1/2	2-3/8	1-3/8	165	1700
508	1/2 - 13	2-1/2	2-3/8	2-1/8	184	1700
509	10 - 24	1	1-1/4	15/16	22	375
510	1/4 - 20	27/32	1-1/8	5/8	15	400
511	10 - 24	27/32	1-1/8	5/8	15	400

6H Series in combination with 500 series Beam Clamp
Conduit and Pipe Hanger

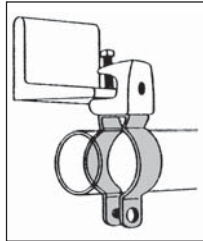

Features

- Accommodates 1/2" through 4" EMT or rigid conduit
- Can be used for either vertical or horizontal installation
- 6H-TB Series is threaded so there are less parts to handle or drop
- Installs easily with a screwdriver

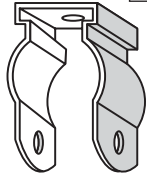

6H Series
without bolt
Fig. 1

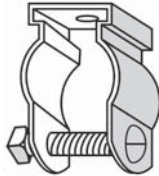

6H--B Series
with bolt and hex nut
Fig. 2



6H-T Threaded Series
threaded without bolt
Fig. 3



6H-TB Threaded Series
threaded with bolt
Fig. 4

Without Bolt		With Bolt		EMT	Rigid Conduit or Pipe	Qty. per Box
Cat. No.	Fig. No.	Cat. No.	Fig. No.			
6H0	1	6H0-B	2	1/2"	3/8"-1/2"	100
6H0-T	3	6H0-TB	4	1/2"	3/8"-1/2"	100
6H1	1	6H1-B	2	3/4"	3/4"	100
6H1-T	3	6H1-TB	4	3/4"	3/4"	100
6H2	1	6H2-B	2	1"	1"	100
		6H2-TB	4	1"	1"	100
6H2 1/2	1	6H2 1/2B	2	1-1/4"	-	100
		6H2 1/2-TB	4	1-1/4"	-	100
6H3-SC	1	6H3-B	2	1-1/2"	1-1/4"	100
		6H3-TB	4	1-1/2"	1-1/4"	100
6H4	1	6H4-B	2	-	1-1/2"	100
		6H4-TB	4	-	1-1/2"	100
6H5	1	6H5-B	2	2"	2"	100
		6H5-TB	4	2"	2"	100
6H6	1	6H6-B	2	2-1/2"	2-1/2"	100
6H7	1	6H7-B	2	3"	3"	100
6H8	1	6H8-B	2	3-1/2"	3-1/2"	100
6H9	1	6H9-B	2	4"	4"	100

Standard Finish - Electrogalvanized (no suffix). Use SS suffix for Stainless Steel.
Load rating: 500 lb with a safety factor of 3. (For weight per 100 see page 46)