



Shield-Kon[®]

Grounding Connectors

RSK Connectors and Installation Tools.....	228 - 230
Two-Piece Grounding Connectors for Shielded and Coaxial Cable	231 - 233
Colour-Coded Tool and Die Selection System.....	234 - 235
Connector for Multiple or Overall Shielded Cables Grounded with One Compression.....	236- 239

Shield-Kon®

RSK Connectors and Installation Tools

Ground-lead trap accommodates multiple ground wires

One piece. Epsilon shaped connector is insulated with colour-coded Mylar*

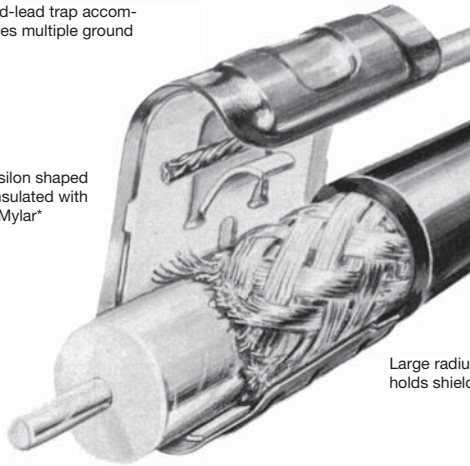

Large radius of connector holds shield

Conductor Dielectric

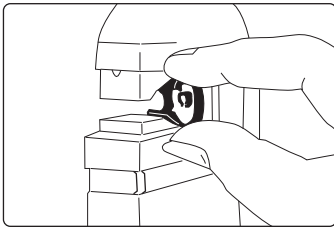

1. After handles are fully opened, insert connector into plastic die ... small radius on the top.

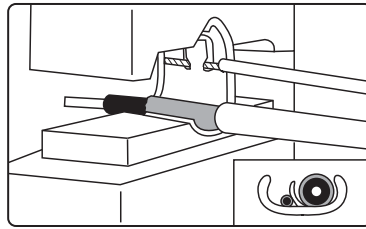

2. Insert ground wires into ground-lead trap, and shielded cable into large opening. Squeeze handle of WT-740 or 13300 tool to form connector around the shield.

RSK Connector for Shielded or Coaxial Cable

This solderless, wrap-around connector terminates shielded cable in seconds ... with uniform precision. It is particularly well suited for production work in aircraft, aerospace and electronic industries where size and weight are of importance.

Once crimped, it provides a compact, lightweight, low resistance, high strength connection. It meets and exceeds the performance requirements of MIL-F-21608. The connector works equally well on braided, wrapped, or foil shields and has the added advantage of being able to be used as a mid-span termination. Only four sizes are needed over the range of .050" to .300" diameter.

- Requires no heat to install.
- Low installed cost.
- Compact, low profile connector.
- One piece "Wrap-around" design.
- Inventory savings.
- Easily inspected.

Shield-Kon®

RSK Connectors and Installation Tools

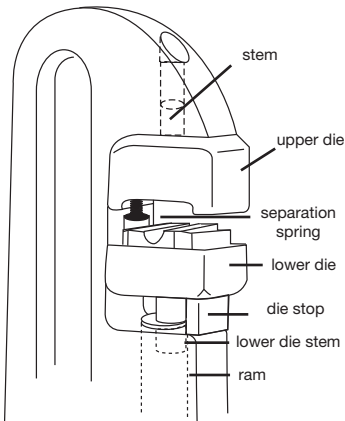

The WT-740 hand tool and 13300 pneumatic tool both feature interchangeable dies for forming the full line of RSK connectors. The Shure-Stake® mechanism (on the WT-740) assures positive, controlled forming of connectors.

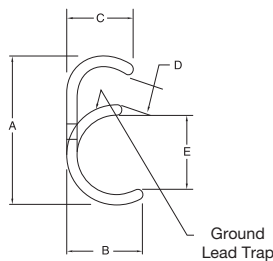
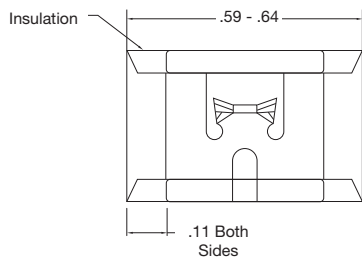

Connector Cat. No. & Colour	Dia. of Shield	Die Cat. No.	Ground Wire Range	Die Gage Cat. No.	Application Tool	
RSK101 Red	(1.27-1.78 mm) .050-.070 in.	101A	1 or 2 #24 AWG STR or 1 #22 AWG STR	101AG	Hand Tool WT740	
	(1.80-2.26 mm) .071-.089 in.	101B		101BG		
RSK201 Blue	(2.29-2.54 mm) .090-.100 in.	201C	1 or 2 #22 AWG STR or 1 #20 AWG STR	201CG		
	(2.56-3.00 mm) .101-.118 in.	201D		201DG		
	(3.022-3.33 mm) .119-.131 in.	201E		201EG		
	(3.35-3.63 mm) .132-.143 in.	201F		201FG		
RSK301 Yellow	(3.66-4.11 mm) .144-.162 in.	301G	1 or 2 #22 AWG STR or 1 or 2 #20 AWG STR	—		Air Tool 13300
	(4.14-4.70 mm) .163-.185 in.	301H		—		
	(4.72-5.10 mm) .186-.201 in.	301J		—		
RSK401 Green	(5.13-5.84 mm) .202-.230 in.	401K	1 or 2 #20 AWG STR or 1 #18 AWG STR	401KG		
	(5.87-6.35 mm) .231-.250 in.	401L		—		
	(6.37-6.98 mm) .251-.275 in.	401M		—		
	(7.01-7.62 mm) .276-.300 in.	401N		401NG		

How to use connector die and tool selection chart

1. Use a calibrated measuring tool lightly over shield for most accurate measurement. Rotate shielded wire to pick up high spots on cable. Use "Diameter of Shield" column to match the measured dimension.
2. Select connector and die for WT-740 or 13300 tool from appropriate column.

- Notes: 1. Do not solder-dip ends of ground leads.
2. For ground wire combinations not covered in table, consult Technical Service.

Cat. No.	Dimensions					Copper Thickness	Colour
	A	B	C	D	E		
RSK-101	.31	.16	.18	.06	.15	.02	Red
RSK-201	.38	.22	.18	.06	.18	.02	Blue
RSK-301	.47	.28	.24	.07	.22	.03	Yellow
RSK-401	.69	.43	.37	.08	.37	.03	Green

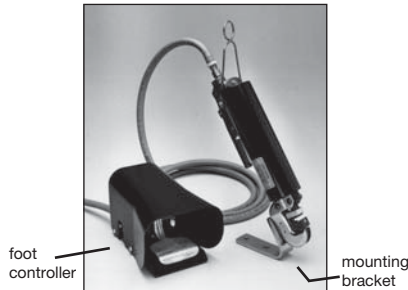
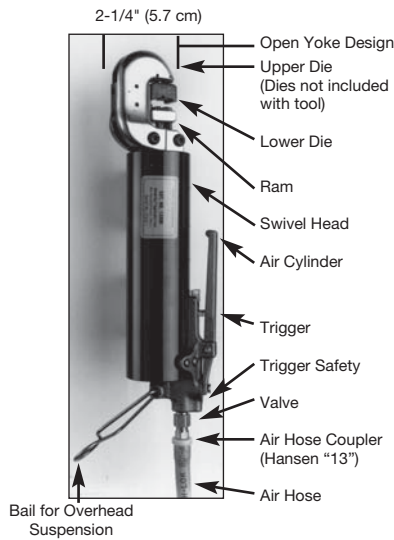

13301 Bench Mounting Kit Converts Easily to Foot Control

The "13300" tool may be converted easily from a hand actuated type to a foot actuated type by the addition of the bench mounting kit, Cat. No. 13301. The kit contains the foot controller, mounting bracket, and all other required hardware.

"13300" Portable Pneumatic Crimping Tool

Installs RSK Series wrap-around connectors and ground wire to shielded cable in seconds

- Accepts 13 colour-coded precision wrap-around installing dies.
- Lightweight, compact, portable or bail-mounted.
- Bench mountable option.
- Applicable installations meet MIL-F-21608.

Specifications

Operating Air Pressure*: 120 psi* (8.3 Bar) max.

Output Force (at 120 psi): 1250 lb. (567 kg).

Ram Stroke: 1/2 in. (1.3 cm) minimum.

Weight: 3-1/4 lb. (1.4 kg).

Finish: Anodize & Nickel.

Air Hose: 8 ft. (2.44 m.).

Air Hose Coupler: Hansen "13".

* Actual operating pressure required is 60-80 psi (4.1-5.5 Bar.).

Operation

Operation is quick and easy; however, you must follow the detailed instructions enclosed with the 13300 tool. Briefly, this is what you do:

1. Select the proper die set and install it into the tool. Refer to Table on page 177).
2. Select the proper connector and position it in the dies.
3. Insert the ground wire(s) and shielded cable in the connector.
4. Squeeze the trigger to complete the installation.

Warning: Keep hands clear of dies to avoid injury.

Warning: Never crimp energized wires.

Performance Specification for Shield-Kon® RSK Connectors

Construction

Material: Copper conforming to CDA No. 110.

Finish: Electro-deposited tin in accordance with MIL-T-10727A.

Insulation: Type A Mylar* polyester film, colour-coded for size identification.

Test Criteria

Shield-Kon RSK connectors meet the requirements of MIL-F-21608 for the following environmental and functional criteria:

Voltage drop: 9 millivolts maximum at 1 ampere after environmental exposure.

Insulation dielectric strength: 500 VRMS at 60 Hz for one minute.

Temperature Cycling: Between the limits of -65 degrees C and +125 degrees C.

Vibration: .03 inch double amplitude between 10 and 55 Hz for 6 hours on each of two axis.

Pullout strength: 15 pounds minimum for 22 AWG, and 19 pounds min. for 20 AWG.

Corrosion resistance: 48 hours in 5% salt fog.

In addition, hypot tests have shown that the cable manufacturers' specified working voltage rating is maintained after the installation of Shield-Kon RSK connectors. It is, however, still advisable to evaluate the suitability of these connectors and verify their performance for the particular application.

Shield-Kon®

Two-Piece Grounding Connectors for Shielded and Coaxial Cable

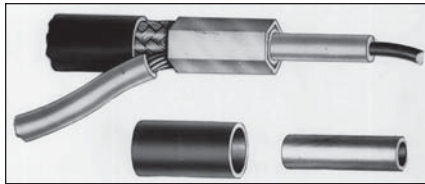

A reliable method for grounding, terminating and insulating shielded and coaxial cable

All-around hex compression is applied with a simple tool. The result: a permanent, compression joint. With or without grounding wire (insertable from front or back), reliable grounding of termination is done quickly, neatly, and accurately.

The Thomas & Betts hex compression is a permanent method which has reliably connected literally hundreds of millions of installations in communications, aerospace, electronic, telephone, radio and TV. The termination is completed quickly, neatly, accurately ... at a greatly reduced production cost.

Installation Method

1. Slip outer sleeve over insulation jacket, after stripping. Trim braid to within 1/2" of insulation.



2. Fan braid by rotating center conductor and slip inner sleeve under braid.

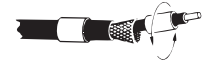

3. Position inner sleeve to extend about 1/16" beyond braid.



4. Slip one No. 22 or No. 20 ground wire under outer sleeve (front or back), and slide outer sleeve over braid.



For Daisy chain grounding, two ground wires can be accommodated by selecting the proper size outer sleeve.

5. Outer sleeve covers all exposed strands.

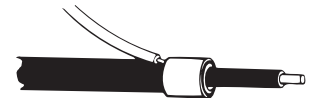

6. Compress in specified tool. (Tool will not release until full compression stroke is completed.)

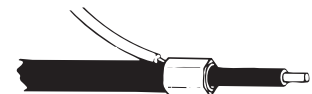

Warning: Never install on energized wire.

Shield-Kon®

Two-Piece Grounding Connectors for Shielded and Coaxial Cable

O.D. Inner Insulation

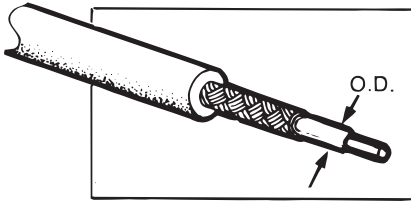

O.D. Inner Insulation

Determine O.D. of inner conductor insulation with measuring tool.

Inner Sleeve-Cat. GSB



Hard bronze inner sleeve is installed under braid.

Length 5/16"

Tin Plated as standard.

Connector Inner Sleeve

Cat. No.	Colour Code	I.D.	O.D.	Military Spec. No.
GSB-046	Tin	.046	.075	21981-046
GSB-058	Yellow	.058	.083	21981-058
GSB-063	Red	.063	.088	21981-063
GSB-071	Green	.071	.096	21981-071
GSB-080	Blue	.080	.103	21981-080
GSB-090	Orange	.090	.113	21981-090
GSB-096	Purple	.096	.119	21981-096
GSB-101	Yellow	.101	.124	21981-101
GSB-109	Red	.109	.131	21981-109
GSB-115	Tin	.115	.146	21981-115
GSB-124	Green	.124	.145	21981-124
GSB-128	Tin	.128	.152	21981-128
GSB-134	Orange	.134	.156	21981-134
GSB-149	Blue	.149	.179	21981-149
GSB-156	Red	.156	.193	21981-156
GSB-165	Tin	.165	.194	21981-165
GSB-175	Green	.175	.215	21981-175
GSB-187	Yellow	.187	.227	21981-187
GSB-194	Blue	.194	.226	21981-194
GSB-205	Orange	.205	.245	21981-205
GSB-219	Tin	.219	.250	21981-219
GSB-225	Yellow	.225	.256	21981-225
GSB-232	Red	.232	.263	21981-232
GSB-250	Green	.250	.281	21981-250
GSB-261	Blue	.261	.297	21981-261
GSB-266	Tin	.266	.297	21981-266
GSB-275	Orange	.275	.306	21981-275
GSB-281	Yellow	.281	.331	21981-281
GSB-287	Tin	.287	.327	21981-287
GSB-297	Red	.297	.335	21981-297
GSB-312	Purple	.312	.362	21981-312
GSB-348	Orange	.348	.400	21981-348
GSB-375	Blue	.375	.406	21981-375

Inner sleeve

1. Use a measuring tool over the inner conductor insulation. Rotate wire to pick up high spots on cable that are non-symmetrical.
2. Add .005 to the diameter of the conductor insulation. Select inner sleeve with this I.D. or nearest larger I.D.

Two-Piece Grounding Connectors for Shielded and Coaxial Cable

Non-insulated Outer Sleeve-Cat. GSC



Soft bronze outer sleeve slips over the braid and ground wire.

Length 1/4"

Insulated Outer Sleeve-Cat. GSR



Soft bronze outer sleeve with nylon insulator slips over the braid and ground wire.

Connector Outer Sleeves

Cat. No.	Colour Code	I.D.	O.D.	Military Spec. No.
Non-insulated				
GSC-101	Tin	.101	.124	21980-101
GSC-128	Blue	.128	.152	21980-128
GSC-149	Purple	.149	.179	21980-149
GSC-156	Yellow	.156	.193	21980-156
GSC-175	Blue	.175	.215	21980-175
GSC-187	Orange	.187	.227	21980-187
GSC-194	Red	.194	.226	21980-194
GSC-199	Tin	.199	.235	21980-199
GSC-205	Yellow	.205	.245	21980-205
GSC-219	Green	.219	.250	21980-219
GSC-225	Purple	.225	.256	21980-225
GSC-232	Orange	.232	.263	21980-232
GSC-261	Yellow	.261	.297	21980-261
GSC-275	Tin	.275	.306	21980-275
GSC-281	Purple	.281	.331	21980-281
GSC-287	Blue	.287	.327	21980-287
GSC-297	Green	.297	.335	21980-297
GSC-312	Yellow	.312	.362	21980-312
GSC-327	Tin	.327	.372	21980-327
GSC-348	Orange	.348	.393	21980-348
GSC-359	Purple	.359	.399	21980-359
GSC-375	Yellow	.375	.406	21980-375
GSC-405	Red	.405	.453	21980-405
GSC-415	Blue	.415	.463	21980-415
GSC-425	Tin	.425	.475	
GSC-460	Tin	.460	.510	21980-460
GSC-500	Green	.500	.550	21980-500
Insulated				
GSR-101	Tin	.101	.124	18121-101
GSR-128	Blue	.128	.152	18121-128
GSR-149	Purple	.149	.179	18121-149
GSR-156	Yellow	.156	.193	18121-156
GSR-175	Blue	.175	.215	18121-175
GSR-187	Orange	.187	.227	18121-187
GSR-194	Red	.194	.226	18121-194
GSR-199	Tin	.199	.235	18121-199
GSR-205	Yellow	.205	.245	18121-205
GSR-219	Green	.219	.250	18121-219
GSR-225	Purple	.225	.256	18121-225
GSR-232	Orange	.232	.263	18121-232
GSR-261	Yellow	.261	.297	18121-261
GSR-275	Tin	.275	.306	18121-275
GSR-281	Purple	.281	.331	18121-281
GSR-287	Blue	.287	.327	18121-287
GSR-297	Green	.297	.335	18121-297
GSR-312	Yellow	.312	.362	18121-312
GSR-327	Tin	.327	.372	18121-327
GSR-348	Orange	.348	.393	18121-348
GSR-359	Purple	.359	.399	18121-359
GSR-375	Yellow	.375	.406	18121-375
GSR-405	Red	.405	.453	18121-405
GSR-415	Blue	.415	.463	18121-415
GSR-460	Tin	.460	.510	18121-460
GSR-500	Green	.500	.550	18121-500

Outer sleeve

1. Add .060 to O.D. of inner sleeve selected. Use this dimension to select outer sleeve with this I.D. or the nearest larger I.D.
2. Use **GSC** prefix to order non-insulated outer sleeve. Use **GSR** prefix to order nylon insulated outer sleeve.

Note: All parts are standard tin plated per MIL-T-10727A

Note: Inner and outer connector catalogue nos. conform to MIL-F-21608.

These suffixes are NOT colour-coded. They are not stock items.

Add suffix **PF** for plain finish.

Add suffix **T** for tin plate with no colour code.

Add suffix **NP** for nickel plate.

Consult regional sales office for delivery and minimum quantities.

Shield-Kon®

Colour-Coded Tool and Die Selection System

Hand Tools WT-440 and WT-540

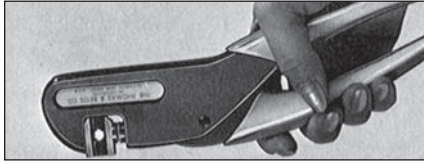

This series features interchangeable dies for minimum tool investment. Dies are available for a range of GSC, GSR and GSW series connectors. The steel frame cushion-grip handles combine to provide greater operator efficiency. This series features straight-line action and Shure-Stake® design. Order dies separately. WT-440 – 8" long, 1 lb., WT-540 – 10³/₈" long, 1 lb. 9 ounces.

Power Tool



This series is ideal for production installation since it is small and light enough to be hand held ... 10" in length, 3 lb. 2 ozs. These air hydraulic tools develop 2,000 lb. crimping pressure from operating pressure of 90 lb. Installs GSC, GSR connectors.

11901A – Hand Actuated – Closed yoke

11902A – Foot Actuated – Closed yoke

11903A – Hand Actuated – Hand held or bench mounted – Open yoke

11904A – Foot Actuated – Hand held or bench mounted – Open yoke

Non-insulated Outer Sleeve Connector

Cat. No.	Colour Code	Tools With Fixed Dies	"GSC" Tools	
			Die Nos. For WT-440	Die Nos. For 11901A
GSC-101	Tin	WT-419	4419	11989
GSC-128	Blue	WT-400	4400	11970
GSC-149	Purple	WT-401	4401	11971
GSC-156	Yellow	WT-402	4402	11972
GSC-175	Blue	WT-403	4403	11973
GSC-187	Orange	WT-406	4406	11976
GSC-194	Red	WT-406	4406	11976
GSC-199	Tin	WT-406	4406	11976
GSC-205	Yellow	WT-408	4408	11978
GSC-219	Green	WT-408	4408	11978
GSC-225	Purple	WT-409	4409	11979
GSC-232	Orange	WT-410	4410	11980
GSC-261	Yellow	WT-411	4411	11981
GSC-275	Tin	WT-412	4412	11982
GSC-281	Purple	WT-414	4414	11984
GSC-287	Blue	WT-414	4414	11984
GSC-297	Green	WT-414	4414	11984
GSC-312	Yellow	WT-415	4415	11985
GSC-327	Tin	WT-416	4416	11986
GSC-348	Orange	WT-417	4417	11987
GSC-359	Purple	–	5450	–
GSC-375	Yellow	–	5451	–
GSC-405	Red	–	5452	11988
GSC-415	Blue	–	5452	11988
GSC-425	Tin	–	5454	–
GSC-460	Tin	–	5456	–
GSC-500	Green	–	5457	–

Note: Die Nos. 5450 – 5459 are only for WT-540 tool.

Shield-Kon®

Colour-Coded Tool and Die Selection System

Hand Tools WT-440 and WT-540

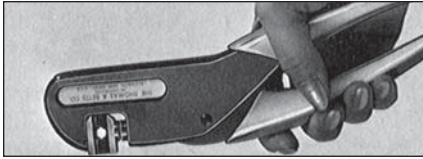

Hand Tools WT-440 and WT-540

This series features interchangeable dies for minimum tool investment. Dies are available for a range of GSC, GSR and GSW series connectors. The steel frame cushion-grip handles combine to provide greater operator efficiency. This series features straight-line action and Shure-Stake® design. Order dies separately. WT-440 – 8" long, 1 lb., WT-540 – 10³/₈" long, 1 lb. 9 ounces.

Power Tool

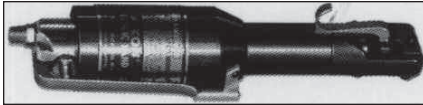

This series is ideal for production installation since it is small and light enough to be hand held ... 10" in length, 3 lb. 2 ozs. These air hydraulic tools develop 2,000 lb. crimping pressure from operating pressure of 90 lb. Installs GSC, GSR connectors.

- 11901A – Hand Actuated – Closed yoke
- 11902A – Foot Actuated – Closed yoke
- 11903A – Hand Actuated – Hand held or bench mounted – Open yoke
- 11904A – Foot Actuated – Hand held or bench mounted – Open yoke

Insulated Outer Sleeve

Cat. No.	Tools With Fixed Dies	"GSR" Tools	
		Die Nos. For WT-440 WT-540	Die Nos. For 11901A Power Tool
GSR-101	WT-400	4400	11970
GSR-128	WT-401	4401	11971
GSR-149	WT-403	4403	11973
GSR-156	WT-406	4406	11976
GSR-175	WT-408	4408	11978
GSR-187	WT-410	4410	11980
GSR-194	WT-410	4410	11980
GSR-199	WT-410	4410	11980
GSR-205	WT-411	4411	11981
GSR-219	WT-411	4411	11981
GSR-225	WT-411	4411	11981
GSR-232	WT-412	4412	11982
GSR-261	WT-414	4414	11984
GSR-275	WT-415	4415	11985
GSR-281	WT-417	4417	11987
GSR-287	WT-417	4417	11987
GSR-297	WT-417	4417	11987
GSR-312	–	5451	–
GSR-327	–	5452	11988
GSR-348	–	5452	11988
GSR-359	–	5452	–
GSR-375	–	5453	–
GSR-405	–	5455	–
GSR-415	–	5455	–
GSR-460	–	5458	–
GSR-500	–	5459	–

Note: Die Nos. 5450 – 5459 are only for WT-540 tool.

Shield-Kon®

Connector for Multiple or Overall Shielded Cables Grounded With One Compression

Cushioned Shield-Kon® Connector



A special feature is the smooth, heat stabilized nylon insulator which acts as a cushion to protect conductor insulation from abrasion. This molded blue nylon insulator is wedge-fitted to the hard brass inner collector rings.



Overall Shield and Multiple-Conductor Shield

Particularly useful in small space applications as in this 90° connector. The three different ring techniques ground the multiple conductor shields as well as the overall outer braid.

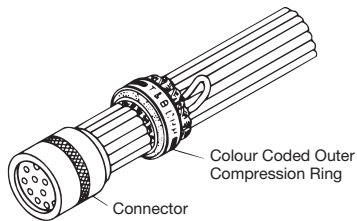
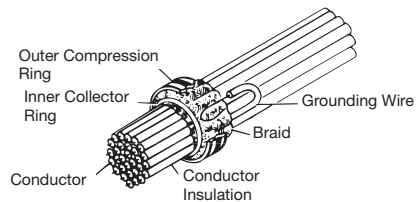

Typical installation for multi-pin connector application. After shielding is extracted, attach ground wire(s) to connector pin and place between collector and compression rings. Colour-coded die will make a 360° compression in one stroke. For complete assembly procedures refer to instructions enclosed with the product.

Warning: Never install on energized wire.

The Shield-Kon Connector System for multiple-conductor shielded cable is based on the principle of cold swaging. It utilizes a two-piece compression connector colour-coded to match the proper die. The connector consists of a hard brass collector inner ring with a tough, smooth insulator and a soft copper compression outer ring. Each set of rings and matching installing die will connect a minimum of 5 shielding braids with one ground wire. The maximum number of braids is limited only by the space between the inner and outer rings.

The design advantages are:

1. Positive selection of inner and outer sleeves and installing die by a complete colour-coded system.
2. A more reliable grounding termination because only one ground wire connection is made – conventional daisy chain jumper method is eliminated.
3. Smaller, more compact bundle is easy to inspect.
4. Only one ground wire is required, however additional ground wires may be used if needed.
5. Smooth insulator protects conductor insulation.
6. With one stroke of the tool, the interlace die will produce a 360° compression uniformly securing all individual shields around the connector.

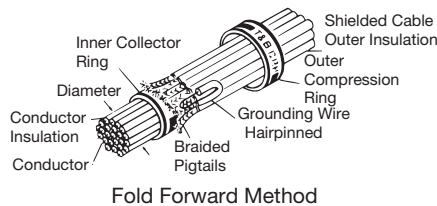

Fold Forward Method

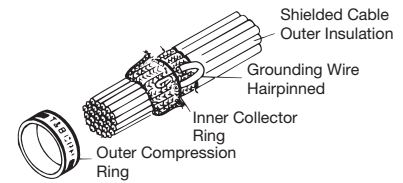

Fold Back Method

Single Fold Shield Methods

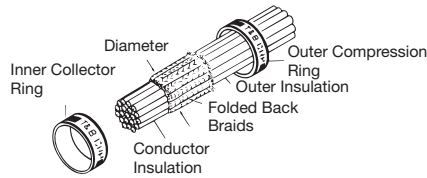

Double Fold Method

Grounding wire can be inserted from front or back

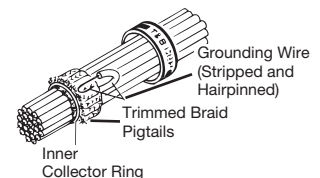

Shield-Kon®

Connector for Multiple or Overall Shielded Cables Grounded With One Compression

Multi-Shielded Cable Connector Installation Procedure

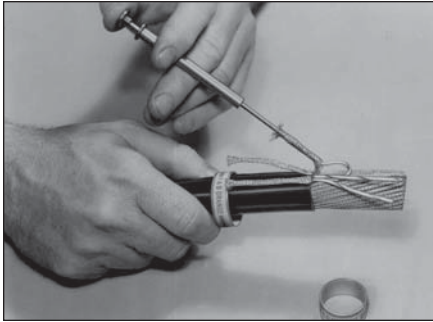

1. After overall insulation is removed to expose shielded cables, each conductor must be freed from the shielding braid. The Thomas & Betts lead extractor tool simplifies this operation by pushing the inner conductor through an opening in the shielding braid. The braid is then folded back until all conductors are freed. See Lead Ext. Table, page 235.

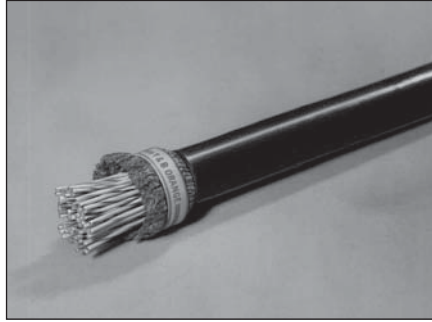

3. Position outer compression ring over the flattened shielding braid, locating it over the center of the inner collector ring. Braid may be trimmed even with the edge of the outer compression ring before or after compression. Ground wire or wires may be inserted between the outer compression ring and the shield prior to compression.

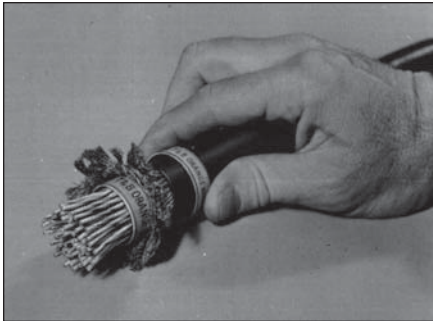

2. Flattened shielding braids are evenly distributed around the periphery of the inner collector ring.



4. Selection of compression dies is determined by colour code on rings. The dies are colour coded to match the rings. The appropriate dies are easily inserted or removed by depressing die locking button shown.



5. The prepared cable is placed in the installing die and compressed. Tool operates on hydraulic power output developing 9800 ±200 psi operating pressure.

6. Completed installation of the “single fold”-“fold forward” method typifies the reliability, compactness and neatness which is obtained with all Thomas & Betts recommended installation methods.

- Easier and quicker to install – one compression grounds all conductors simultaneously.
- Improved reliability – multiple connector errors eliminated.
- Smaller, less bulky bundle diameter – eliminates individual connectors and daisy chained jumpers.
- Reduce installed cost – fewer parts, less installation and inspection time.
- Smooth nylon insulator acts as cushion to protect conductors.

Warning: Never install on energized wire.

Connector for Multiple or Overall Shielded Cables Grounded With One Compression

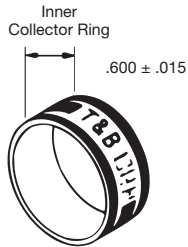

Colour-coded marking

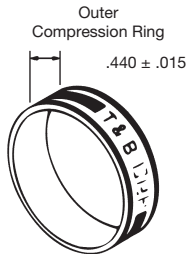

Colour-coded marking

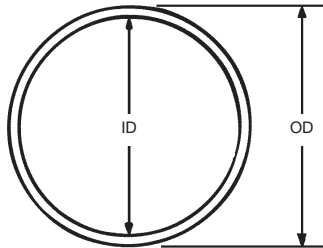

Connectors for Shielded Cable

Cat. No.	I.D.	O.D.	Installing Die Cat. No.	Colour-Code
Inner Ring				
GSB-430	.430	.500	GS590	Red
GSB-550	.550	.620	GS710	Blue
GSB-670	.670	.750	GS840	Grey
GSB-810	.810	.880	GS1010	Brown
GSB-920	.920	1.000	GS1130	Green
GSB-1040	1.040	1.120	GS1250	Pink
GSB-1122	1.122	1.192	GS1332	Orange
GSB-1224	1.224	1.294	GS1440	Purple
GSB-1353	1.353	1.423	GS1563	Yellow
GSB-1425	1.425	1.545		
Outer Ring				
GSC-590	.590	.670	GS590	Red
GSC-710	.710	.790	GS710	Blue
GSC-840	.840	.920	GS840	Grey
GSC-1010	1.010	1.090	GS1010	Brown
GSC-1130	1.130	1.210	GS1130	Green
GSC-1250	1.250	1.330	GS1250	Pink
GSC-1332	1.332	1.412	GS1332	Orange
GSC-1440	1.440	1.520	GS1440	Purple
GSC-1563	1.563	1.643	GS1563	Yellow
GSC-1670	1.670	1.750		
GSC-1795	1.795	1.875		
GSC-1920	1.920	2.000		

Materials: Inner ring; Copper Alloy ASTM B135, Alloy 2
Outer ring; Copper ASTM B188

Finish: Electro Tin, MIL-T-10727 A, Type 1. For temp. up to 260°C (500°F), nickel; QQN290.

Note: The inner ring, outer ring and installing die are a matched set.

Shield-Kon®

Connector for Multiple or Overall Shielded Cables Grounded With One Compression

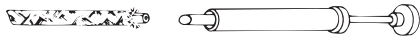

After insulation is stripped off, flare exposed braid. Push flared end of braid back causing braid to bulge.

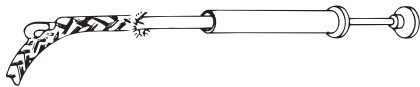

Retract plunger and slide tube over wire until desired breakout point is reached.

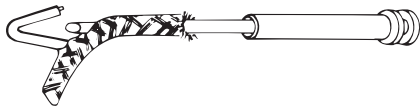

Retract plunger and slide tube over wire until desired breakout point is reached.



One Installing Tool Accommodates All Die Sizes

- Thomas & Betts installing tool can be used as a bench mounted or portable tool.
- Twenty-two colour-coded dies install complete range of all commonly used shielded cables; dies are easily snapped in or out.
- Interface die with 360° compression provided uniform pressure around circumference of connector.
- Narrow silhouette head permits complete operator visibility during compression cycle.

Warning: Never install on energized wire.

Lead Extractor

Cat. No.	For Lead Dia. Up To	Plunger Colour-code
WT-045B	.045	Red
WT-060W	.062	White
WT-080G	.093	Blue
WT-100B	.125	Green
WT-130Y	.140	Yellow

Installing Tool

Cat. No.	Description
13640	Installing Head (order dies separately)
13606	Hand-Foot Pump
13600	Electric Hydraulic Pump
13620	Hand Switch
13589A	Foot Switch
13619	Hydraulic Hose 10 ft.
13760	Air-Operated Hydraulic Pump