



LDX-NX SERIES

6, 12 and 24V
NEMA-4X Rated



Type: _____
 Project/Location: _____
 Contractor: _____
 Prepared By: _____
 Date: _____
 Model No.: _____

TYPICAL SPECIFICATIONS

Supply and install the **Ready-Lite® NEMA-4X Rated LDX-NX Series** battery unit. The unit shall be specifically designed for high abuse areas and wet locations. The unit enclosure shall be of fiberglass-reinforced polyester and shall include a hinged door, fully gasketed and locked with two corrosion-resistant screws. The emergency head(s) shall be installed at the bottom of the unit and/or at both sides and shall be covered by a UV-resistant polycarbonate cover. The bottom head shall include one or two lamps as specified. The unit shall come with two heads at the sides, each with one MR16 lamp. The lamps shall be high-efficiency, long-life halogen or LED type of: __V __W as specified. The lamp swivels shall be easily adjustable without tools. The unit enclosure shall include a test switch and a pilot light. The unit shall include sealed, maintenance-free Lead-Calcium batteries and an electronic module for the battery charger and other emergency lighting functions. The charger shall be computer-tested and its maximum charge voltage set in the factory with ± 1% tolerance.

A pulse-type charger shall be employed to promote long battery life and reduce the potential for grid corrosion. The charger shall provide a continuous high charge to recharge the battery and when the battery is at full capacity, the charger will shut off. Periodically the charger shall provide a pulse of energy to keep the battery topped off. The charger shall be current limited, temperature compensated and short-circuit proof. The unit shall be furnished with an electronic lockout circuit, which will connect the battery when the AC circuit is activated, and an electronic brownout circuit, which will activate the emergency lights when utility power dips below 75% of nominal voltage. A low voltage battery protection circuit shall be provided and will disconnect the battery from the fused output circuit at the end of discharge. When specified, the unit equipped with the **Ready-Lite®** Auto-Diagnostic feature shall include a micro-controller based charger board that will generate an automatic test for 1 minute every 30 days, 10 minutes every six months and 30 minutes every 12 months.

The micro-controller circuitry shall ensure equipment readiness and reliability by continuously monitoring every critical function of the unit. If a component failure occurs, the pilot light located on the front of the unit will change color from green to red and will flash indicating a fault. A detailed diagnostic legend shall be available next to the pilot light and shall provide fault identification (battery, charger circuitry, lamps) for maintenance personnel. The unit shall be capable of full recharge in compliance with CSA specifications and supply the rated load for a minimum of a 1/2 hour to 87.5% of the rated battery voltage. The unit shall be rated 120V or 347V, 60 Hz and shall have an output of: __ V __ W. The unit shall be **Ready-Lite®** model: _____.

FEATURES

- Delivers great pathway illumination up to 70 feet, center to center (with MH20 lamp)
- Fully gasketed fiberglass reinforced polyester housing - NEMA 4X
- Solid-state pulse-type charger – current – limited, temperature-compensated, short-circuit proof and reverse-polarity protected
- Unit comes standard with electronic lockout and brownout circuits
- Sealed dust-proof transfer relay, test switch and LED indicator lights
- Long-life, maintenance-free sealed lead acid battery
- Standard 120/347VAC input voltage
- NEXUS® compatible (for more information on NEXUS®, please consult your sales representative)
- Certified CSA C22.2 No. 141-15

WIRE GUARDS

460.0034-RL	wall mount
-------------	------------

POWER CONSUMPTION AND UNIT RATING

MODEL	AC SPECS	WATTAGE CAPACITY					
		30MIN	1H00	1H30	2H00	4H00	
LDX6-72NX	0.22/0.08 A	72	42	30	24	12	
LDX6-108NX		108	63	45	36	18	
LDX6-180NX		180	105	75	60	30	
LDX12-144NX	0.40/0.14 A	144	84	60	48	24	
LDX12-200NX	0.41/0.14 A	200	117	83	67	33	
LDX12-250NX	120/347VAC	250	120	90	83	42	
LDX12-360NX		360	200	160	120	60	
LDX24-144NX		0.55 / 0.20 A	144	84	60	48	24
LDX24-288NX		0.67 / 0.23 A	288	168	120	96	48
LDX24-350NX		0.67 / 0.23 A	350	200	144	120	60
LDX24-432NX	0.67 / 0.23 A	432	250	180	140	72	

Type: _____
 Project/Location: _____
 Contractor: _____
 Prepared By: _____
 Date: _____
 Model No.: _____

DIMENSIONS

Dimensions are approximate and subject to change.

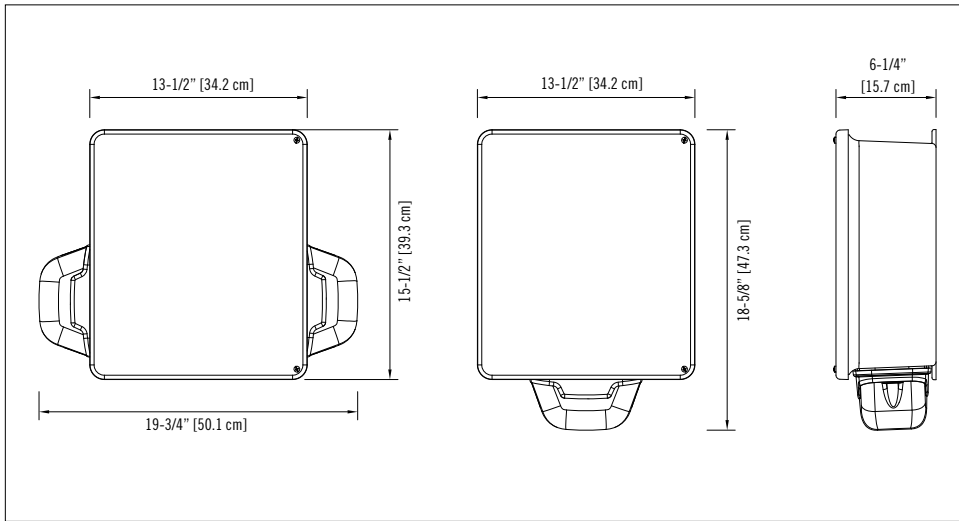

LDX-NX SERIES

6, 12 and 24V
 NEMA-4X Rated

ORDERING INFORMATION

SERIES	CAPACITY	HOUSING	SPECIAL OPTIONS	# OF HEADS	HEAD STYLE/LAMP WATTAGE	OPTIONS	AC VOLTAGE
LDX6= 6V	-72= 72W -108= 108W -180= 180W	NX= NEMA-4X	Blank= standard AD= auto-diagnostic* ADN= auto-diagnostic non audible* NEX= NEXUS® system interface** NEXRF= wireless NEXUS® system interface**	Blank= no heads 1= single head bottom, one lamp 2= single head bottom, two lamps S= no head bottom with single head on each side 1S= single head bottom with single head on each side, three lamps 2S= double head bottom with single head on each side, four lamps	LD1= MR16 LED, 6V-4W LD7= MR16 LED, 12V-4W LD9= MR16 LED, 12V-5W LD10= MR16 LED, 12V-6W LD13= MR16 LED, 24V-4W LD14= MR16 LED, 24V-6W RM6= MR16, 6V-6W RM10= MR16, 6V-10W RM12= MR16, 12V, 24V-12W RM20= MR16, 12V, 24V-20W RMH20= MR16-IR 12V-20W, high output	D3= time delay (15 mins.)	Blank= 120/347 VAC input U27= 277VAC input
LDX12= 12V	-144= 144W -200= 200W -250= 250W -360= 360W	NX= NEMA-4X					
LDX24= 24V	-144= 144W -288= 288W -350= 350W -432= 432W	NX= NEMA-4X					

*Minimum lamp load required: 20% of unit capacity
 **Not all options available with NEXUS® System. Please consult your sales representative

EXAMPLE: LDX24-144NX2RM12