

TYPICAL SPECIFICATIONS

Supply and install the **Ready-Lite[®] Ultima[™] Series** combination emergency light battery unit and Exit Sign. The standard equipment shall operate with a dual voltage input of 120/347VAC. The unit shall be suitable for wall or ceiling mount. The unit frame and face plates shall be made of injection-molded durable high-impact thermoplastic and come standard with snap in/out chevrons. No screws are necessary to hold the faceplate or backplate to the housing. The one-piece thermoplastic frame is molded in white (optional black). The faceplates shall feature a uniformly illuminated legend.

The light source shall be light emitting diodes (LED) and shall provide illumination in normal and emergency operation and shall be mounted inside the combination housing. Red LED technology shall be **ALINGAP**. An LED-sensitive diffuser shall be mounted behind the legend to provide the 6" high by 3/4" stroke letters with even illumination. The unit shall be equipped with two emergency heads with tool-less adjustable swivels (lamps of 12W or less) and long-life LED type lamps of ___ V and ___ W. Each lamp shall be protected by a snap-on, shock-absorbent, transparent polycarbonate cover.

The unit shall be equipped with a test switch and a green pilot light, located on the face plate above the EXIT legend. The battery charger shall be driven by a micro-controller. All electronic circuitry (charger, LED driver, LED's) shall be installed on a single printed circuit board PCB. The unit equipped with self-testing / self-diagnostic features shall automatically self test for one minute every 30 days, 10 minutes in the 6th month and 30 minutes annually. When a fault is detected, the bi-colour pilot light shall turn from green to red and shall flash, identifying the source of the failure: battery, charger circuitry, lamp load, LED strip.

The Exit Sign module shall be CSA-C860 approved.

The combo unit shall be **Ready-Lite[®]** Model: _____ .

ULTIMA[™] FAMILY



WIRE GUARDS

460.0078-RL	wall mount
-------------	------------

POWER CONSUMPTION

MODEL	AC SPECS	WATTAGE CAPACITY					
		30MIN	1H00	1H30	2H00	4H00	
Exit Sign Module	less than 2W	-	-	-	-	-	
L20	120/347VAC	0.11/0.04 A	20	15	12	8	-
L50		50	30	24	16	8	
12L50		50	30	24	16	8	
12H5	0.22/0.08 A	50	36	24	18	9	



ULTIMA[™] SERIES

Thermoplastic
Combination Unit

FEATURES

The **Ultima[™] Series** of combination units (emergency light battery unit with an Exit Sign) are designed with aesthetics, ease of installation and performance in mind.

- One-pack combination of battery unit and Exit Sign, a compact and contemporary design
 - Durable injection-molded thermoplastic housing with push-to-snap design
 - Available in single or double face configurations both with means for ceiling mounting
 - Comes with the **Ready-Lite[®] Ultima[™] E22** canopy and field-selectable snap chevrons for quick and easy installation
 - Exit Sign module illuminated by long-life **ALINGAP** red LEDs
 - Two LED lamps, shielded by a clear polycarbonate cover
 - LED lamps with life expectancy 50,000+ hours
 - Sealed, maintenance-free, Lead-Calcium or Nickel-Metal-Hydrate batteries
 - Dual voltage input: 120/347VAC or 120/277VAC.
 - Optional vandal-resistant shield with tamper-proof screws
 - Certified CSA C22.2 No.141
 - Optional advance diagnostics circuitry available
 - Advanced diagnostics capabilities (specific load requirements)
- See warranty details at: www.tnb.ca/en/brands/ready-lite



ULTIMA™ SERIES

Thermoplastic
Combination Unit



DIMENSIONS

Dimensions are approximate and subject to change.

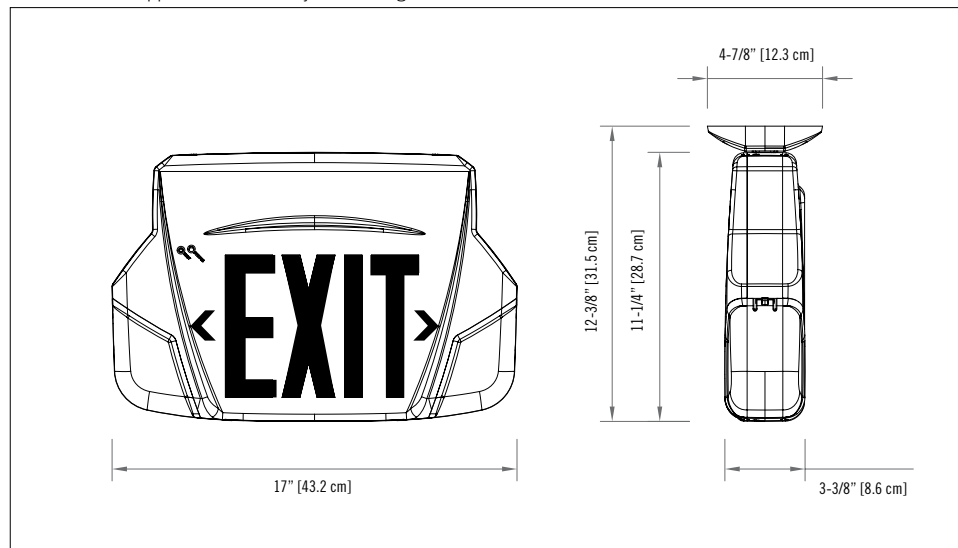

ORDERING INFORMATION

POWERPACK	# OF HEADS	HEAD STYLE/WATTAGE	FACES/MOUNTING	VOLTAGE	COLOUR	LEGEND	OPTIONS
L20 = 6V-20W lead cal L50 = 6V-50W lead cal 12L50 = 12V-50W lead cal 12H5 = 12V-50W NiMH	Blank = no heads -2 = two heads	Blank = no heads LD1 = MR16 LED, 6V-4W LD2 = MR16 LED, 6V-5W LD7 = MR16 LED, 12V-4W LD9 = MR16 LED, 12V-5W LD10 = MR16 LED, 12V-6W	-ULT1 = single face ceiling or wall mount -ULT2 = double face ceiling mount -ULTIN = single face wall mount (less canopy) -ULTU = universal, 2 faces backplate and canopy	3 = 120/347VAC 2 = 120/277VAC	B = black W = factory white	Blank = red legend G = green legend	Blank = no options AD = auto-diagnostics ADN = auto-diagnostics, non-audible NEX = NEXUS® system interface ¹ NEXRF = wireless NEXUS® system interface ¹ BA = brushed aluminum exit stencil D3 = time delay (15 minutes) TP = tamper-proof screws ² VR = polycarbonate shield with tamper-proof screws ²

¹ Not all options available with NEXUS® System. Please consult your sales representative

² **091957-RL**= tamper-proof bit (sold separately)
VR is not available with -ULTU

EXAMPLE: L20-2LD7-ULT13W