



**N**  
new product

## RGC-BLD Series

Steel, compact, 6V



### FEATURES

- "Buil-in" 3W LED heads
- Compact steel cabinet with corrosion-resistant undercoating
- Quick and easy installation – pre-assembled cordset, no batteries or board to remove before installation
- Universal Spider knockout pattern for junction box mounting
- Fully automatic solid-state charger with test switch and AC-on pilot light
- Sealed dust-proof transfer relay circuit and low-voltage disconnect
- Long-life, maintenance-free sealed Lead-Acid battery
- Standard input 120VAC with line cord installed
- 120/347VAC without line cord
- Meets or exceeds CSA C22.2 No. 141-15

See warranty details at: [www.tnb.ca/en/brands/lumacell](http://www.tnb.ca/en/brands/lumacell)

### TYPICAL SPECIFICATIONS

The contractor shall install the Lumacell® RGC-BLD Series battery units. The emergency lighting system shall consist of fully automatic equipment with two emergency lighting heads. The unit shall be rated 6V with a capacity of 27W for 30 minutes of emergency operation. The charger shall be factory set with a charging voltage tolerance of  $\pm 1\%$  to enable a longer battery life. The metal cabinet shall be made of steel with anti-corrosion undercoating. The unit shall be CSA 22.2 No.141-15 certified.

The unit shall be Lumacell® model: \_\_\_\_\_ .

### WIRE GUARDS

460.0080-L	Wall Mount
------------	------------

### DIMENSIONS

Dimensions are approximate and subject to change.

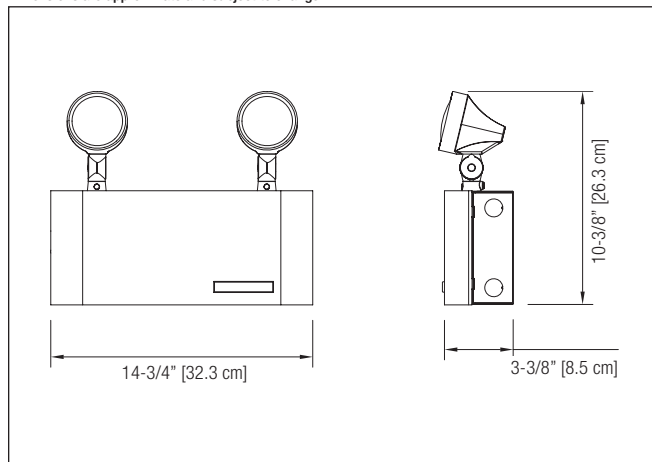

### POWER CONSUMPTION AND UNIT RATING

MODEL	AC SPECS		WATTAGE CAPACITY				
			30MIN	1H	1H30	2H	4H
RGC27	120/347 VAC	0.06/0.02A	27	15	11	9	-

### ORDERING INFORMATION

SERIES	CAPACITY	# OF HEADS	HEADS STYLE/WATTAGE	AC VOLTAGE
RGC= 6V	27= 6V-27W	1= One head 2= Two heads	BLD= Built-in LED	Blank= 120VAC input comes with linecord ZC= 277VAC input ZD= 120/347VAC input

EXAMPLE: RGC272BLD

**LUMACELL**

**by ABB**