

ESLNX Series

6, 12 and 24V NEMA-4X rated



Features

- Fully gasketed fiberglass reinforced polyester housing - NEMA 4X
- Solid-state pulse-type charger – current – limited, temperature- compensated, short-circuit proof and reverse-polarity protected
- Unit comes standard with electronic lockout and brownout circuits
- Sealed dust-proof transfer relay, test switch and LED indicator lights
- Long-life, maintenance-free sealed lead acid battery
- Standard 120/347VAC input voltage
- NEXUS® compatible (for more information on NEXUS®, please consult your sales representative)
- Certified CSA C22.2 No. 141-15
- Advanced diagnostics capabilities (specific load requirements)
- **Warranty details at: www.emergi-lite.ca**

nexus®



Wire guards

Ordering code	Description
460.0034-E	Wall mount

Typical specifications

Supply and install the **Emergi-Lite®** NEMA-4X Rated **ESLNX Series** battery unit. The unit shall be specifically designed for high abuse areas and wet locations. The unit enclosure shall be of fiberglass-reinforced polyester and shall include a hinged door, fully gasketed and locked with two corrosion-resistant screws. The emergency head(s) shall be installed at the bottom of the unit and/or at both sides and shall be covered by a UV-resistant polycarbonate cover. The bottom head shall include one or two lamps as specified. The unit shall come with two heads at the sides, each with one LED lamp. The lamps shall be high-efficiency, long-life LED type of: _____ V _____ W as specified. The lamp swivels shall be easily adjustable without tools. The unit enclosure shall include a test switch and a pilot light. The unit shall include sealed, maintenance-free lead-calcium batteries and an electronic module for the battery charger and other emergency lighting functions. The charger shall be computer-tested and its maximum charge voltage set in the factory with $\pm 1\%$ tolerance.

A pulse-type charger shall be employed to promote long battery life and reduce the potential for grid corrosion. The charger shall provide a continuous high charge to recharge the battery and when the battery is at full capacity, the charger will shut off. Periodically the charger shall provide a pulse of energy to keep the battery topped off. The charger shall be current limited, temperature compensated and short-circuit proof. The unit shall be furnished with an electronic lockout circuit, which will connect the battery when the AC circuit is activated, and an electronic brownout circuit, which will activate the emergency lights when utility power dips below 75% of nominal voltage. A low voltage battery protection circuit shall be provided and will disconnect the battery from the fused output circuit at the end of discharge. When specified, the unit equipped with the **Emergi-Lite®** Auto-Diagnostic feature shall include a micro-controller based charger board that will generate an automatic test for 1 minute every 30 days, 10 minutes every six months and 30 minutes every 12 months.

The micro-controller circuitry shall ensure equipment readiness and reliability by continuously monitoring every critical function of the unit. If a component failure occurs, the pilot light located on the front of the unit will change color from green to red and will flash indicating a fault. A detailed diagnostic legend shall be available next to the pilot light and shall provide fault identification (battery, charger circuitry, lamps) for maintenance personnel. The unit shall be capable of full recharge in compliance with CSA specifications and supply the rated load for a minimum of a 1/2 hour to 87.5% of the rated battery voltage.

The unit shall be rated 120V or 347V, 60 Hz and shall have an output of: V W.

The unit shall be **Emergi-Lite®** model: _____ .

ESLNX Series

6, 12 and 24V NEMA-4X rated

Dimensions

Dimensions are approximate and subject to change.

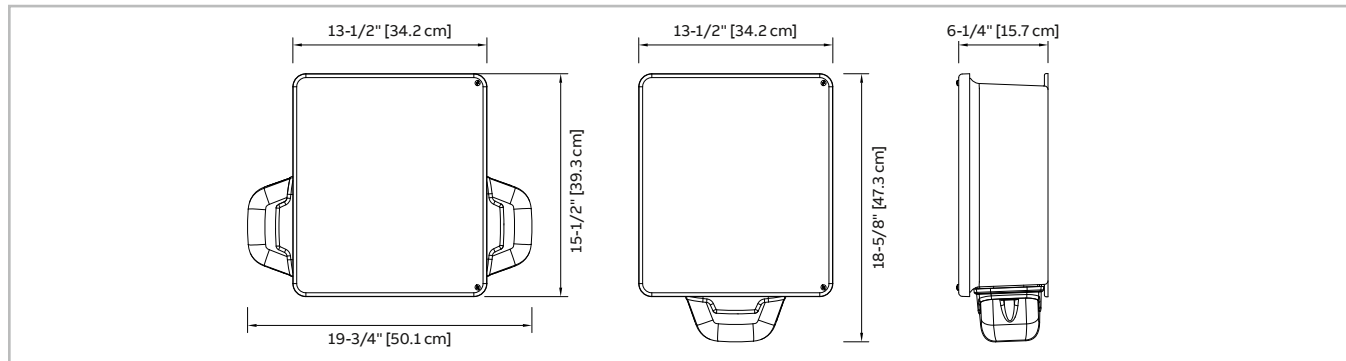

Power consumption and unit rating

Model	AC specs	Wattage capacity				
		30 min	1H00	1H30	2H00	4H00
06ESLNX72	0.22/0.08 A	72	42	30	24	12
06ESLNX108	0.22/0.08 A	108	63	45	36	18
06ESLNX180	0.22/0.08 A	180	105	75	60	30
12ESLNX144	0.40/0.14 A	144	84	60	48	24
12ESLNX200	0.41/0.14 A	200	117	83	67	33
12ESLNX250	120/347VAC 0.41/0.14 A	250	120	90	83	42
12ESLNX360	0.41/0.14 A	360	200	160	120	60
24ESLNX144	0.55 / 0.20 A	144	84	60	48	24
24ESLNX288	0.67 / 0.23 A	288	168	120	96	48
24ESLNX350	0.67 / 0.23 A	350	200	144	120	60
24ESLNX432	0.67 / 0.23 A	432	250	180	140	72

Ordering information

Series	Housing	Capacity	AC voltage	Options	Number of lamps	Lamp wattage
06ESL= 6V	NX= NEMA-4X	72= 72W 108= 108W 180= 180W	-2= 277VAC input Blank= 120/347 VAC input	Blank= no options D3= time delay (15 minutes) NEXRF= wireless NEXUS® system interface ¹ U= auto-diagnostics ² UN= auto-diagnostics non audible ²	/0= no heads /1= single head bottom, one lamp /1S= single head bottom with single lamp on each side, three lamps /2= double head bottom, two lamps /2S= two head bottom with single lamps on each side, four lamps /S= no head bottom with single lamp on each side	LA= MR16 LED, 6V-4W LB= MR16 LED, 6V-5W LG= MR16 LED, 12V-4W LI= MR16 LED, 12V-5W LJ= MR16 LED, 12V-6W LL= MR16 LED, 24V-4W LM= MR16 LED, 24V-6W
12ESL= 12V	NX= NEMA-4X	144= 144W 200= 200W 250= 250W 360= 360W				
24ESL= 24V	NX= NEMA-4X	144= 144W 288= 288W 350= 350W 432= 432W				

¹Not all options available with NEXUS®. Please consult your sales representative.
²Minimum lamp load required: 20% of unit capacity

Example: 06ESLNX72/1LA